

N=Number of poles

Dim.A	$(N-1) \times 10.0$
Dim.B	$N \times 10.0 + 2.0$

A&B Tolerance Δ

Poles	Dim.A	Dim.B
2p-9p	± 0.30	± 0.30
10p-20p	± 0.40	± 0.40
21p-32p	± 0.50	± 0.50

SIGN	DATE	DESCRIPTION	APPROVER
Δ	5/20'09	Add approval "CULUS"	Eris
Δ	10/08'09	Tolerance is changed	Eris
Δ	11/13'12	Change the screw plating specification	Guoxue

THIS IS CAD DRAWING, DO NOT REVISE MANUALLY!!!

MATERIALS ELECTRICAL
 RATED VOLTAGE & CURRENT: 300 V, 20 A
 WITHSTAND VOLTAGE: AC 2000 V/Min
 INSULATION RESISTANCE: 1000 M Ω OR MORE AT DC 500 V
 OPERATING TEMPERATURE RANG: -40 °C ~ +115 °C
 SCREW TORQUE VALUE: 12Lb-In.
 WIRE RANGE: 22 - 12 AWG
 1) MOLDED PARTS: THERMOPLASTIC, UL 94 V-0 BLACK
 2) TERMINAL: BRASS, 0.8t, Tin PLATED
 3) TERMINAL SCREWS: STEEL, M3.5

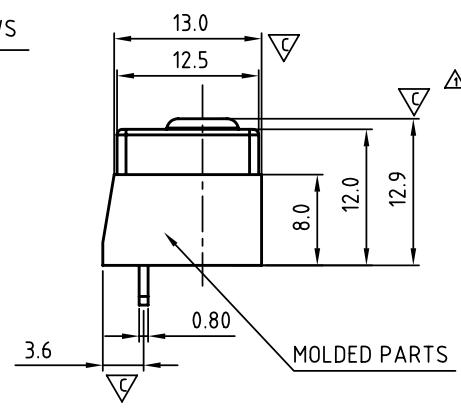
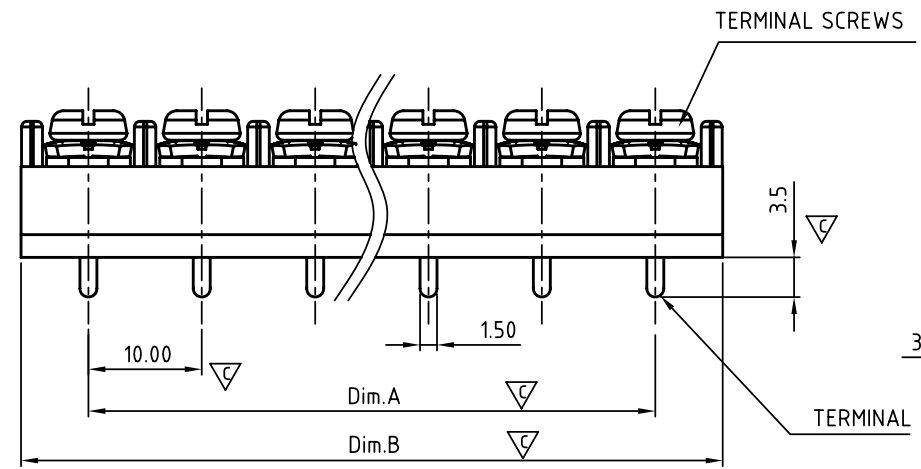

APPROVAL: Δ
 Critical dimension: ∇

YK 61A xx 0 x x 00G
 NO. OF POLES: 02: 2 POLES, 03: 3 POLES, 04: 4 POLES, ..., 32: 32 POLES
 MARK: 0: "@", 1: "ANY", 3: NO MARK
 G RoHS compliant (lead<4%) In copper Alloy
 TERMINAL & SCREW PLATED: 0: TERMINAL & SCREW: G/F, 1: TERMINAL: G/F, SCREW: ZINC, 2: TERMINAL: Sn, SCREW: G/F, 3: TERMINAL: Sn, SCREW: ZINC

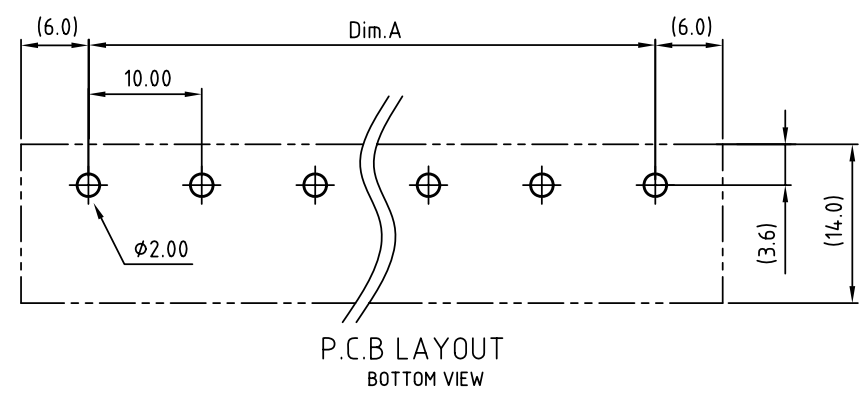

ANYTEK				INSPECTION COPY			
ALL RIGHTS RESERVED. REPRODUCTION OR ISSUE TO THIRD PARTIES IN ANY FORM WHATSOEVER IS NOT PERMITTED WITHOUT WRITTEN AUTHORITY FROM THE PROPRIETOR. PROPERTY OF ANYTEK TECHNOLOGY CO., LTD							
TITLE		YK-61A W/O Flange Series					
PART NO.		YK61Axx0xx00G		DWG NO.		8YK0001-61A	
APPROVED		CHECKED	DESIGNED	DRAWN	CUST NO.		Tolerance
			Guoxue 2012.12.01	Guoxue 2012.12.01			X. ± 0.50 X.X ± 0.30 X.XX ± 0.10 X° $\pm 1^\circ$
				SHEET: 01/01		UNIT: mm SCALE: NONE REV.: D	