

8 7 6 5 4 3 2 1

**NOTES:**

- MOUNTING:** Mounts in a  $\phi .312 \pm .002$  [ $\phi 7.92\text{mm} \pm .05$ ] panel hole on .500 [12.7mm] centers. Panel thickness .031 [.8mm] to .125 [3.18mm]. Panel hole should be deburred, but not chamfered.
- ASSEMBLY:** Insert lens through panel hole, slide lock washer onto lens barrel and twist on retaining ring. PCB mounted LEDs slide into lens when the panel cover is closed or the PCB card is inserted into the case.
- MATERIAL:** Lens- Polycarbonate, UL 94-V2  
Lock Washer- FH Steel, Nickel plate  
Retaining ring - Thermoplastic, U.L. 94 V0 Rated  
Seal- EPDM
- U.S. & Foreign Pat. Issued & Pend.

REVISIONS				
ECN#	REV.	DESCRIPTION	DATE	INITIALS
	1	ADDED CMC 443 & CMS 444; UPDATE DRAWING FORMAT	12-5-08	JG
	001	REVISED PER ECR111009AZ01	4-23-10	SMU

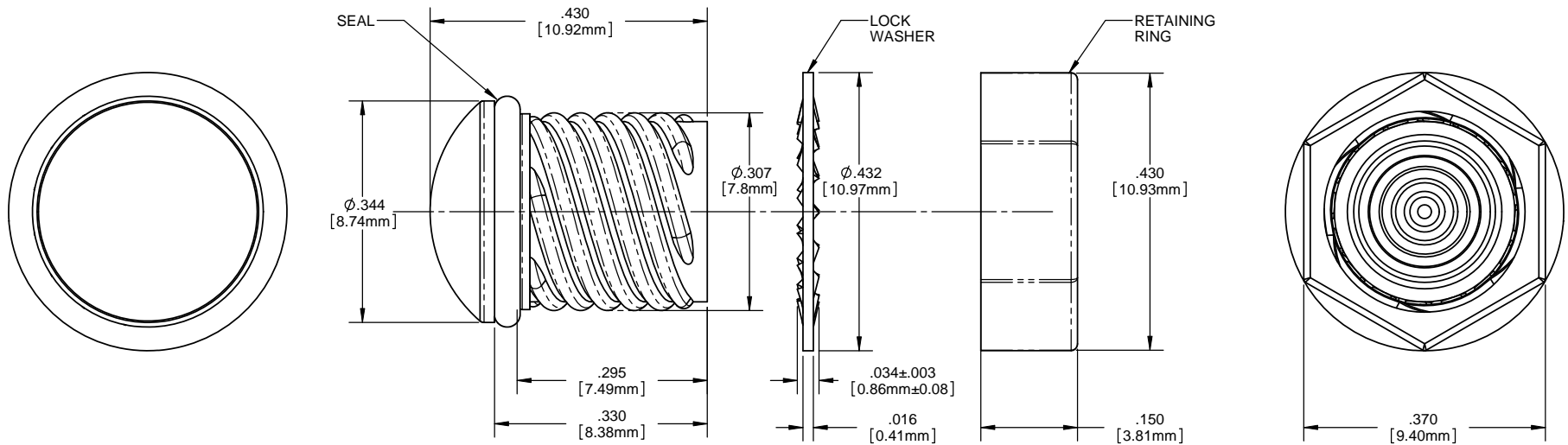

ORDERING CODE : **CMS 442 XXX**

MODEL

LENS COLOR	
RTP	RED TRANSPARENT
ATP	AMBER TRANSPARENT
GTP	GREEN TRANSPARENT
BTP	BLUE TRANSPARENT
YTP	YELLOW TRANSPARENT
CTP	CLEAR TRANSPARENT

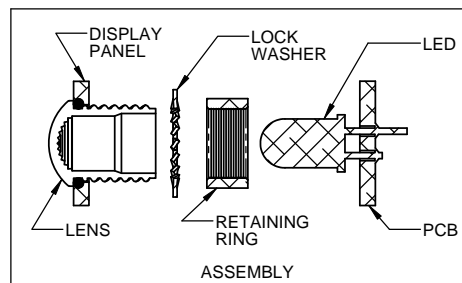

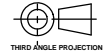
<small>UNLESS OTHERWISE SPECIFIED DIMENSIONS ARE IN INCHES</small> ANGLES DECIMALS ±1° X ±.020 FINISH XXX ±.010 XXX ±.005 <small>BREAK ALL CORNERS AND SHARP EDGES (R1/16")</small>  THIRD ANGLE PROJECTION <small>THE INFORMATION CONTAINED IN THIS DRAWING IS THE SOLE PROPERTY OF VISUAL COMMUNICATIONS COMPANY, INC. AND IS TO BE USED FOR THE MANUFACTURE OF VISUAL COMMUNICATIONS COMPANY, INC. PRODUCTS.</small>	MATERIAL	SEE NOTES	<b>VISUAL COMMUNICATIONS COMPANY, INC.</b> 190 Bosstick Boulevard, Suite 101 San Marcos, CA 92069 USA Phone (760) 560-1300 Fax (760) 560-1301 email vccsales@vccite.com	
	FINISH	SEE NOTES	<b>TITLE: 5MM ROUND STANDARD THREADED FRESNEL LENS WITH SEAL</b>	
APPROVAL	DATE	SIZE	DWG. NO.	REV
DRAWN: SMU	4-23-10	<b>B</b>	<b>CMS 442 XXX</b>	<b>001</b>
CHECKED: DZ	4-23-10	SCALE: 4:1		SHEET 1 OF 1
DO NOT SCALE DRAWING				

8 7 6 5 4 3 2 1