

REV.	DESCRIPTION	DATE	APPROVED
B	Engineering Update w/o Changes	02/17/04	M. C.
C	Material Correction	08/05/04	M. C.
D	Added 03-NL Material	08/19/09	T. Y.

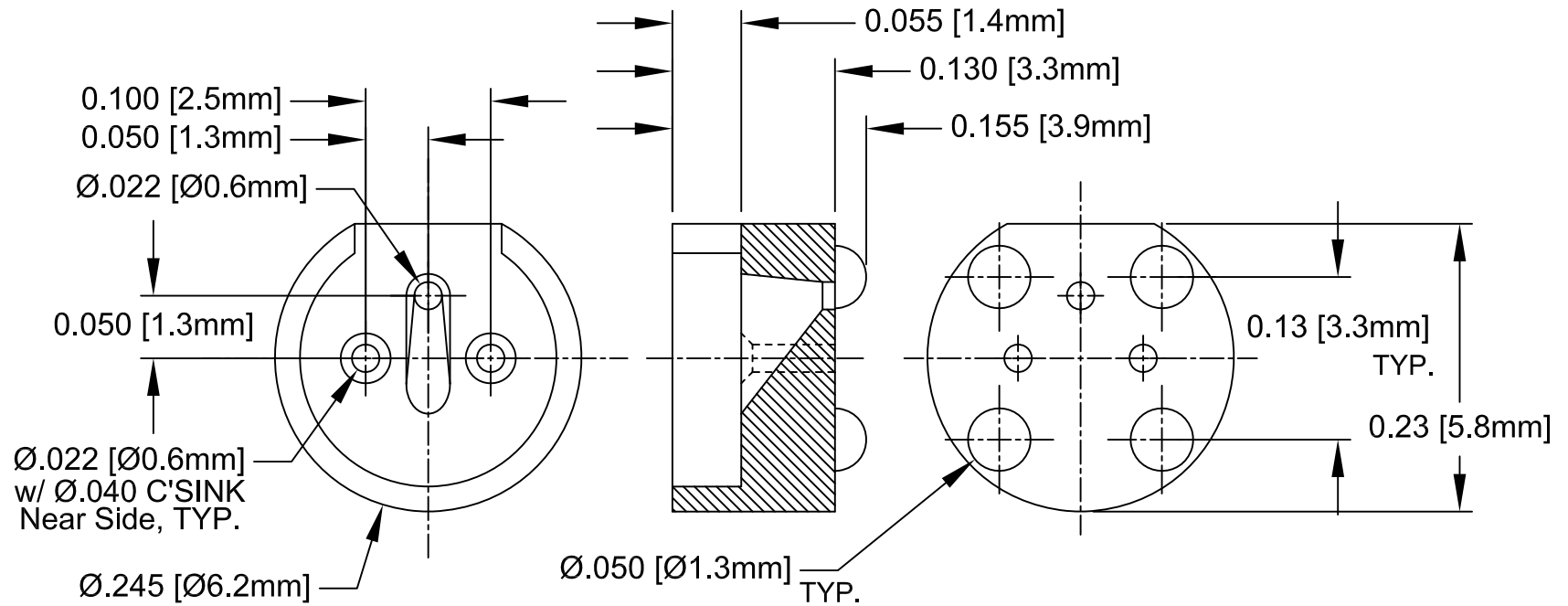

- MATERIAL: NYLON 6/6, 94V-2, NATURAL. BIVAR MATERIAL CODE 03-NL. BASF ULTRAMID NYLON 6/6 A3K NATURAL.
- MATERIAL: NYLON 6/6, 94V-2, NATURAL. BIVAR MATERIAL CODE 21-NL. TICONA NYLON 1310, NYLON 6/6, NATURAL.
- GENERAL SPECIFICATIONS: BIVAR MOLDED COMPONENT SPECIFICATION BV00-E101.

STANDARD TOLERANCE (UNLESS OTHERWISE SPECIFIED)		BIVAR [®]	
DECIMALS	ANGULAR	4 THOMAS, IRVINE, CA. 92618 TEL: (949) 951-8808 FAX: (949) 951-3974	
.X ± .1	X° ± 1°	TITLE: PERM-O-PAD TO-18 MOUNT PART NO: 215-130 REVISION: D	
.XX ± .01			
.XXX ± .005			
DESIGNED: Shane Irving	DATE: 01/03/02	CAGE CODE : 32559	SHEET # 1 OF 1
CHECKED: M. Chen	DATE: 01/03/02	CAD GENERATED DOCUMENT, DO NOT MEASURE DRAWING.	