

Features

- MoCA Compliant Front-End GaAs IC
- Linear Power Amplifier
- Integrated PA Bias Control
- PA Power Down Mode
- Transmit/Receive Switch
- Transmit Power Detector
- 0/3 dB Transmit Attenuator
- 0/15 dB Receive Attenuator
- 3.3 Volt Single Bias
- Integrated Digital Control Logic
- Compatible with EN2512 & EN2552
- Lead-free 3 mm 16-lead PQFN Package
- RoHS* Compliant and 260°C Reflow Compatible
- 50 Ω Characteristic Impedance

Functional Block Diagram

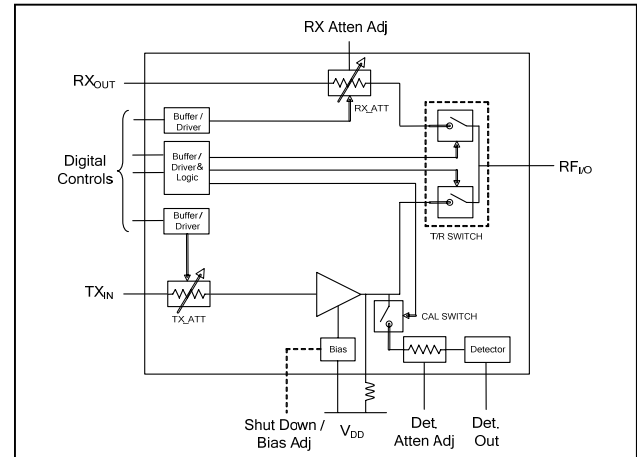

Description

The XZ1004-QT is an integrated front end GaAs IC for MoCA mid-band RF applications which is fully compatible with Entropic Communications chipset. It is housed in an industry standard 3 mm PQFN package and operates from a single 3.3 V bias. The chip includes a power amplifier, transmit/receive switch, power detector, switched attenuators, bias circuits and digital control circuitry. The transmit path includes a 3 dB switched attenuator and power detector for gain adjustment and linearity optimization. A switched attenuator in the receiver provides a 15 dB gain step. The integrated bias circuit stabilizes transmit amplifier performance over temperature and process variation with power down functionality and optional bias adjustment.

The device typically delivers 20 dBm at P1dB and +34 dBm OIP3 across the operating temperature range. The digital inputs control all circuit operating modes and are compatible with Entropic's MoCA chipsets.

Contact M/A-COM Technology Solutions for the complete product datasheet