

THIS DRAWING IS UNPUBLISHED. RELEASED FOR PUBLICATION

© COPYRIGHT - By - ALL RIGHTS RESERVED.

LOC	DIST	REVISIONS			
P	LTR	DESCRIPTION	DATE	DWN	APVD
HB	-	D	REVISED PER ECO-12-005725	26JUL2012	D.L BHY
		E	CHANGE THE VENT HOLE SHAPE FROM RECTANGLE TO CIRCLE ONE. ECO-13-015347	16DEC2013	XL.Y B.F

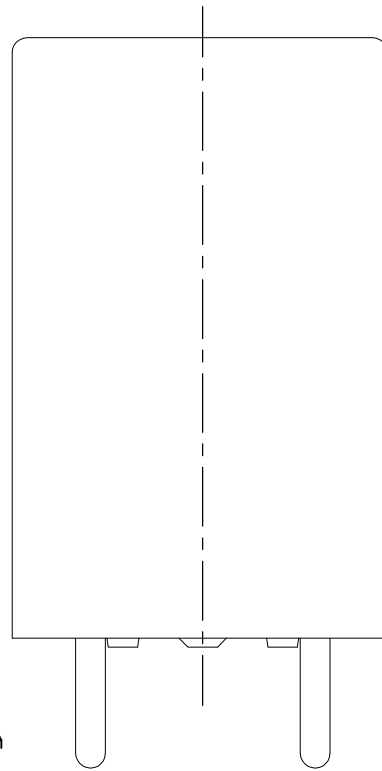
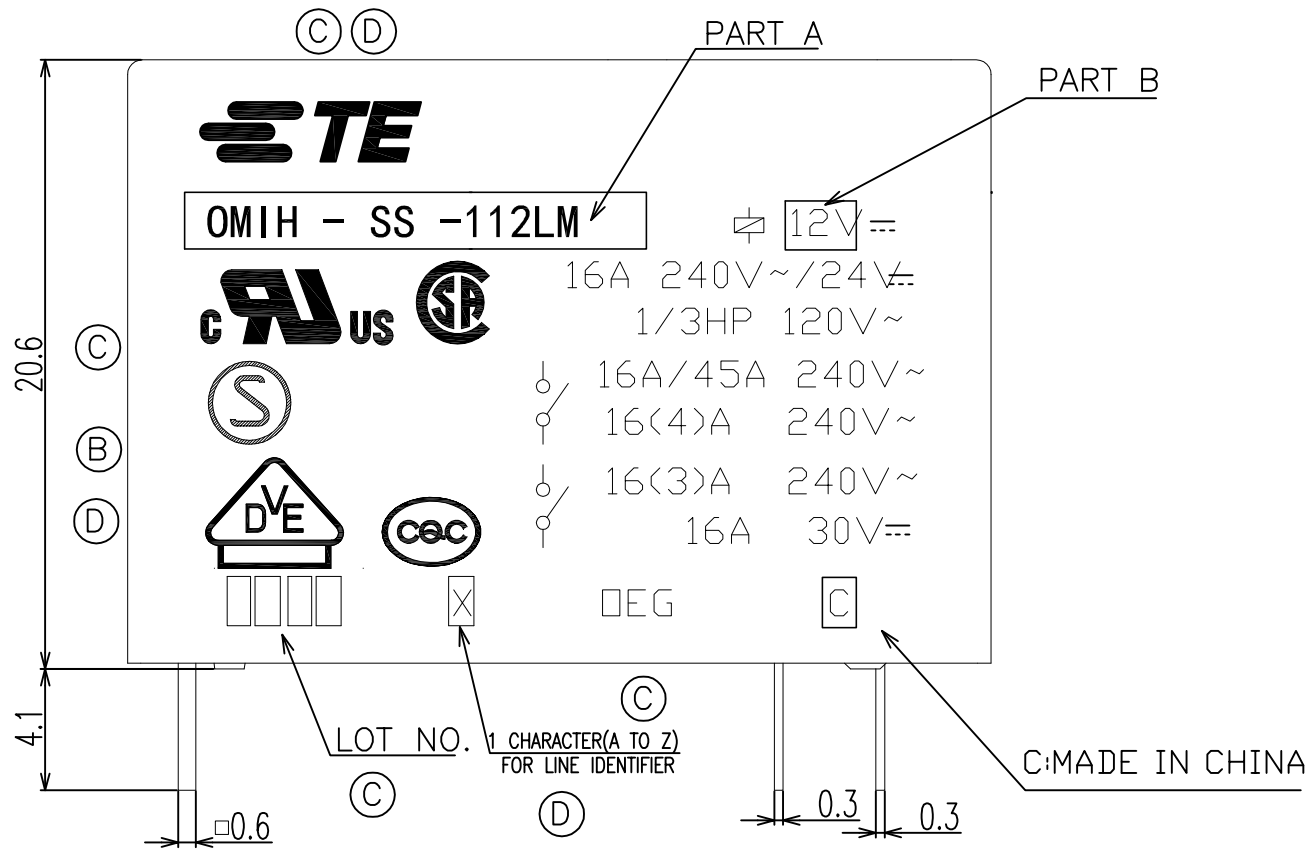
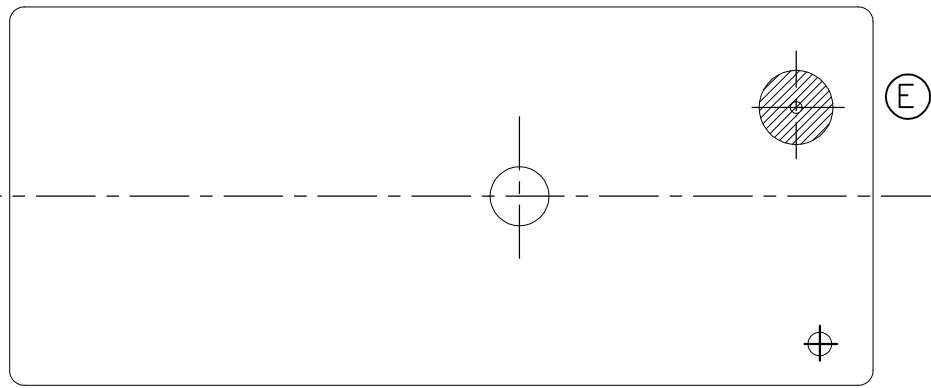

CONNECTION DIAGRAM (BOTTOM VIEW)

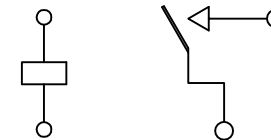

DRILLING DIAGRAM(2/1) (BOTTOM VIEW)

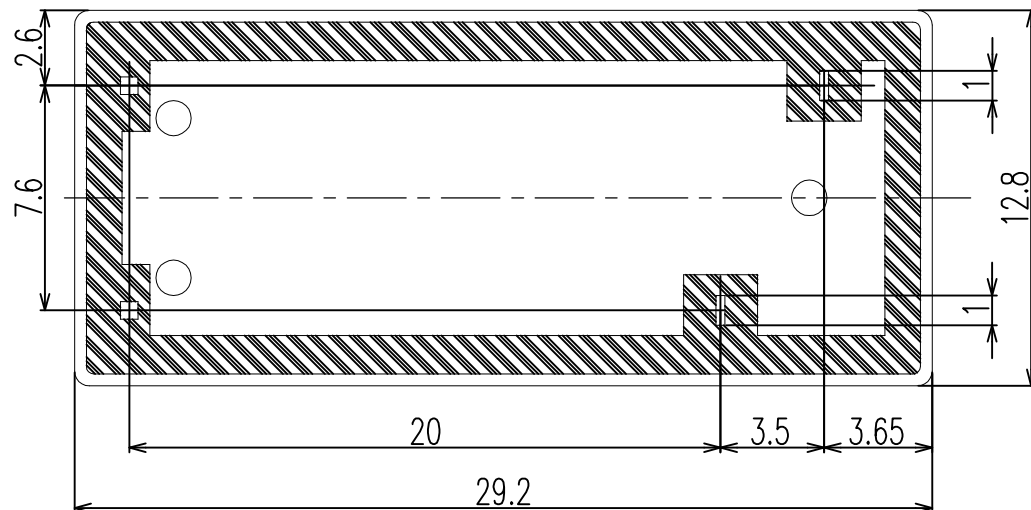
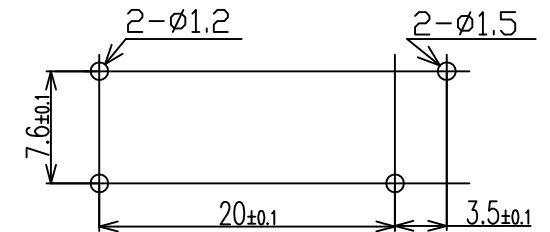

THIS DRAWING IS A CONTROLLED DOCUMENT.		DWN	-		
		CHK	Y.Xiao		
		APVD	N.Funayama		
		PRODUCT SPEC	CH.HSU		
		APPLICATION SPEC	-		
		WEIGHT	-		
		CUSTOMER DRAWING	SCALE	SHEET	REV
			4:1	1 OF 2	E



OMIH CUSTOMER DRAWING

SIZE: A3, CAGE CODE: 00779, DRAWING NO: C-1-1461373-8, RESTRICTED TO: -

THIS DRAWING IS UNPUBLISHED. RELEASED FOR PUBLICATION  
 © COPYRIGHT - By - ALL RIGHTS RESERVED.

LOC	DIST	REVISIONS			
P	LTR	DESCRIPTION	DATE	DWN	APVD
HB	-	-	-	-	-

NOTES:  
 1. LOT NO. SYSTEM AS FOLLOWING:

0 8 2 5  
 WEEK  
 YEAR

2. GENERAL TOLERANCE AS FOLLOWING:

TOLERANCE	
0~0.99mm	±0.1
1mm~2.99mm	±0.2
3mm MIN.	±0.3

③ ④ 3. FOR THE TIN-PLATING OF THE PINS:  
 +0.1mm FOR WIDTH, THICKNESS AND DIAMETER.  
 +0.5mm FOR LENGTH.

OMIH-SH-105LM	5-1440009-4	OMIH-SH-105LM	5V
OMIH-SH-148LM	0-1461373-4	OMIH-SH-148LM	48V
OMIH-SH-148DM	2-1461373-0	OMIH-SH-148DM	48V
OMIH-SH-124LM	1461373-3 (B1)	OMIH-SH-124LM	24V
OMIH-SH-124DM	1-1461373-9	OMIH-SH-124DM	24V
OMIH-SH-118LM	1461373-2	OMIH-SH-118LM	18V
OMIH-SH-112LM	7-1440000-1	OMIH-SH-112LM	12V
OMIH-SH-112DM	1-1461373-8	OMIH-SH-112DM	12V
OMIH-SH-109LM	6-1440000-8	OMIH-SH-109LM	9V
OMIH-SH-109DM	1-1461373-7	OMIH-SH-109DM	9V
OMIH-SH-106LM	0-1461373-1	OMIH-SH-106LM	6V
OMIH-SH-106DM	1-1461373-6	OMIH-SH-106DM	6V
OMIH-SH-105LM	6-1440000-7	OMIH-SH-105LM	5V
OMIH-SH-105DM	1-1461373-5 (A1)	OMIH-SH-105DM	5V
DESCRIPTION	PART NAME	PART A	PART B

RELAY TYPE

		UV RESIN	UV SEAL	16
		EPOXY RESIN	SEAL	15
UL94 V-0		PBT	CASE	14
CLASS E		UEW	MAGNETIC WIRE	13
UL94 V-0		PET	BASE	12
UL94 V-0		PBT	BOBBIN	11
	SOLDER DIP	CP WIRE	COIL TERMINAL	10
UL94 V-0		PPS	CARD	9
		Ag ALLOY	MOVABLE CONTACT	8
		Ag ALLOY	STATIONARY CONTACT	7
		Cu ALLOY	HINGE SPRING	6
	SOLDER DIP	Cu ALLOY	STATIONARY TERMINAL	5
	SOLDER DIP	Cu ALLOY	MOVABLE SPRING	4
		STEEL	CORE	3
		STEEL	ARMATURE	2
		STEEL	YOKE	1
INCOMBUSTIBILITY	TREATMENT	MATERIAL	DESCRIPTION	ITEM

THIS DRAWING IS A CONTROLLED DOCUMENT.		DWN Y.Xiao	 TE Connectivity		
DIMENSIONS: mm		CHK N.Funayama			
TOLERANCES UNLESS OTHERWISE SPECIFIED:		APVD CH.HSU	NAME		
0 PLC ± -		PRODUCT SPEC	OMIH CUSTOMER DRAWING		
1 PLC ± -		APPLICATION SPEC	SIZE	CAGE CODE	DRAWING NO
2 PLC ± -		WEIGHT	A3	00779	C-1-1461373-8
3 PLC ± -			RESTRICTED TO		
4 PLC ± -			-		
ANGLES ± -			SCALE	SHEET	REV
FINISH			4:1	2 of 2	E
MATERIAL			CUSTOMER DRAWING		