

THIS IS ISSUED IN STRICT CONFIDENCE THAT IT IS NOT USED AS A BASIS FOR MANUFACTURE OR SALE AND THAT IT IS NOT COPIED, REPRINTED OR DISCLOSED TO A THIRD PARTY EITHER WHOLLY OR IN PART WITHOUT THE PRIOR WRITTEN CONSENT OF CAL TEST ELECTRONICS, INC.

- BNC MALE TO BNC MALE CABLE ASSEMBLY ON RG58C/U COAXIAL CABLE, 50Ω w/MOLDED BEND RELIEF BOOTS.
- SPECIFICATIONS:  
 CONNECTOR:  
 BNC MALE CRIMP, 50Ω IMPEDANCE PER MIL-C-39012.  
 BODY: BRASS OR DIECAST ZINC.  
 DIELECTRIC: TEFLON.  
 CENTER PIN: BRASS, GOLD PLATED.  
  
 CABLE:  
 RG58C/U PER MIL-C-17  
 50Ω, BLACK, Ø0.195 DIAMETER.  
  
 MOLDED BOOT MATERIAL:  
 PVC, BLACK. (MOLDED TO CABLE AND CONNECTOR).
- RATING:  
 VOLTAGE: 500Vrms.  
 IMPEDANCE: 50Ω.  
 TEMPERATURE: 0° C TO +80° C.

REVISIONS			
REV.	DESCRIPTIONS	DATE	APPROVED
-	CLASS A RELEASED	10/24/02	

**PART NUMBER**

**CT2942-L**

└── LENGTH: (CENTIMETERS)  
 STANDARDS: 25, 50, 100, 120, 150, 200, 250

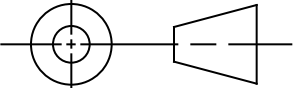
THIRD ANGLE PROJECTION		UNLESS OTHERWISE SPECIFIED DIMENSIONS ARE IN INCHES TOLERANCES ARE: FRACTIONS    DECIMALS ± 1/32        .XX ± .02 .XXX ± .005 DO NOT SCALE DRAWING	CONTRACT NO.		Cal Test Electronics 22820 Savi Ranch Parkway Yorba Linda, CA 92887-4604			
			APPROVALS	DATE	TITLE <b>CABLE ASSEMBLY, BNC MALE TO MALE, RG58C/U, 50Ω</b>			
		MATERIAL	DRAWN <b>WDH</b>	10/20/02	SIZE <b>A</b>	CAGE CODE	DWG. NO. <b>P294200</b>	REV. -
		FINISH	CHECKED		SCALE <b>NONE</b>		SHEET <b>1 OF 2</b>	
NEXT ASSY	USED ON		ENGR.					
APPLICATION			DESIGN ACTIVITY					

THIS IS ISSUED IN STRICT CONFIDENCE THAT IT IS NOT USED AS A BASIS FOR MANUFACTURE OR SALE AND THAT IT IS NOT COPIED, REPRINTED OR DISCLOSED TO A THIRD PARTY EITHER WHOLLY OR IN PART WITHOUT THE PRIOR WRITTEN CONSENT OF CAL TEST ELECTRONICS, INC.

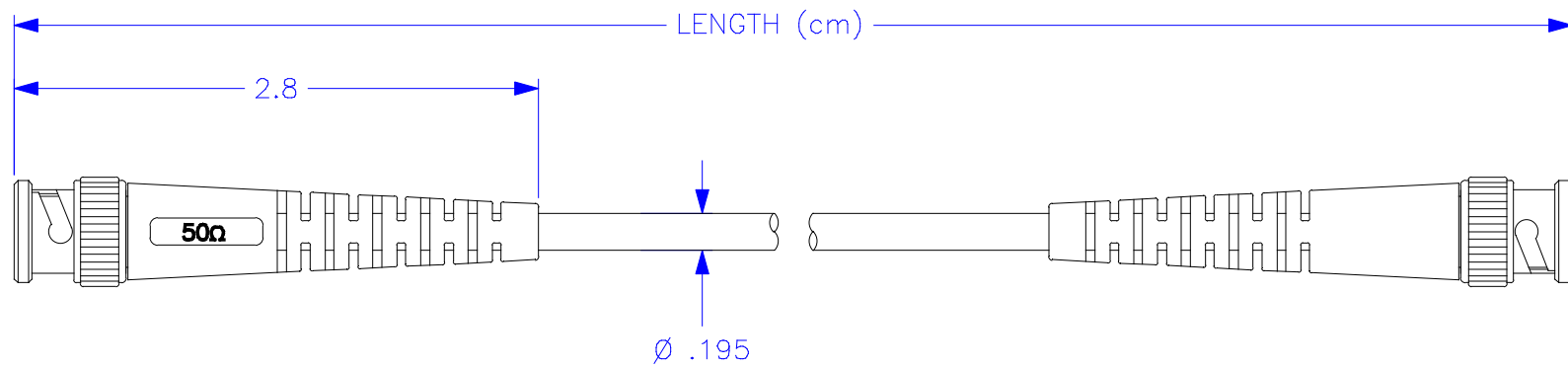

DRAWN		WDH	10/20/02	SIZE	A	CAGE CODE	DWG. NO.	P294200	REV.	-
CHECKED				SCALE	1:1		SHEET	2 OF 2		