

THIS DRAWING IS UNPUBLISHED. RELEASED FOR PUBLICATION  
 © COPYRIGHT - By - ALL RIGHTS RESERVED.

REVISIONS					
P	LTR	DESCRIPTION	DATE	DWN	APVD
AE		REVISED PER ECO-12-012316	05JUL12	KH	MZ
AF		REVISED PER ECO-16-017885	06OCT2017	RS	MZ

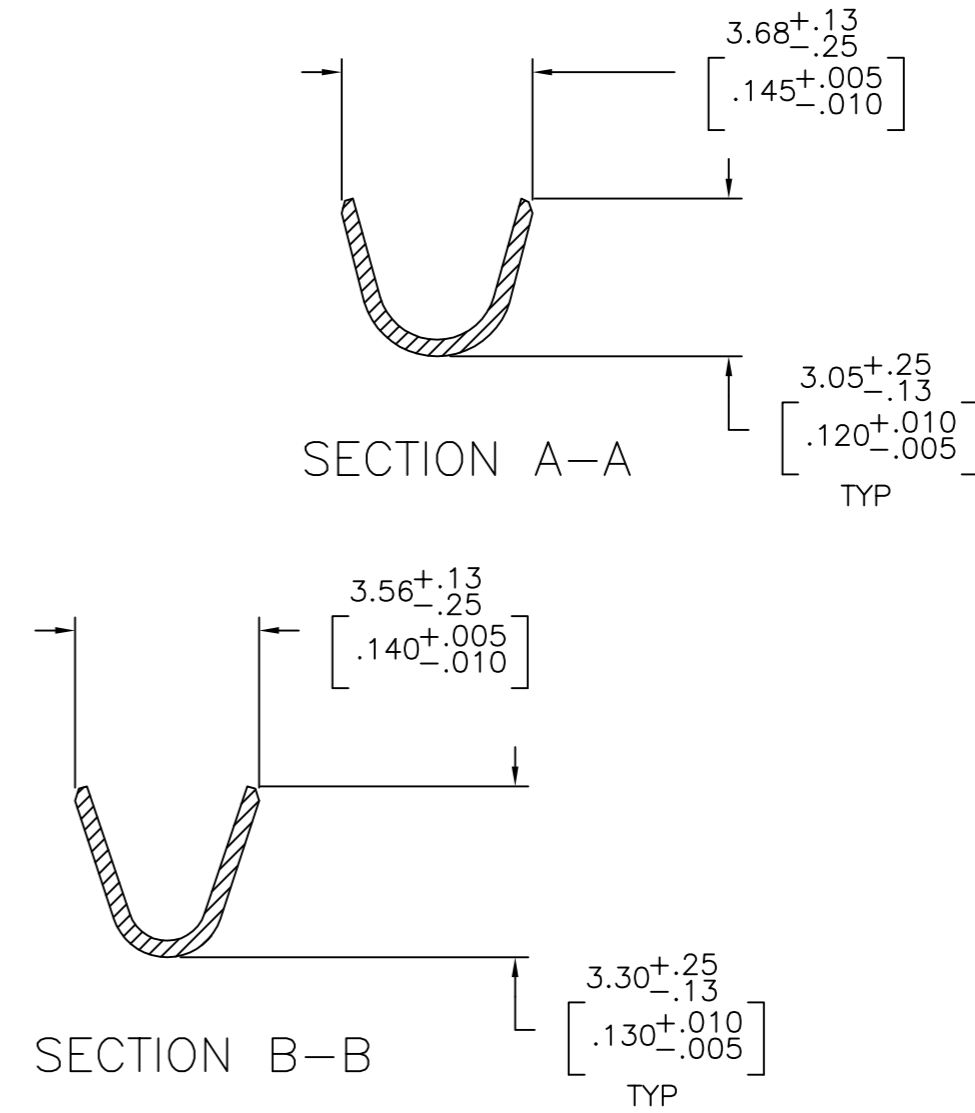
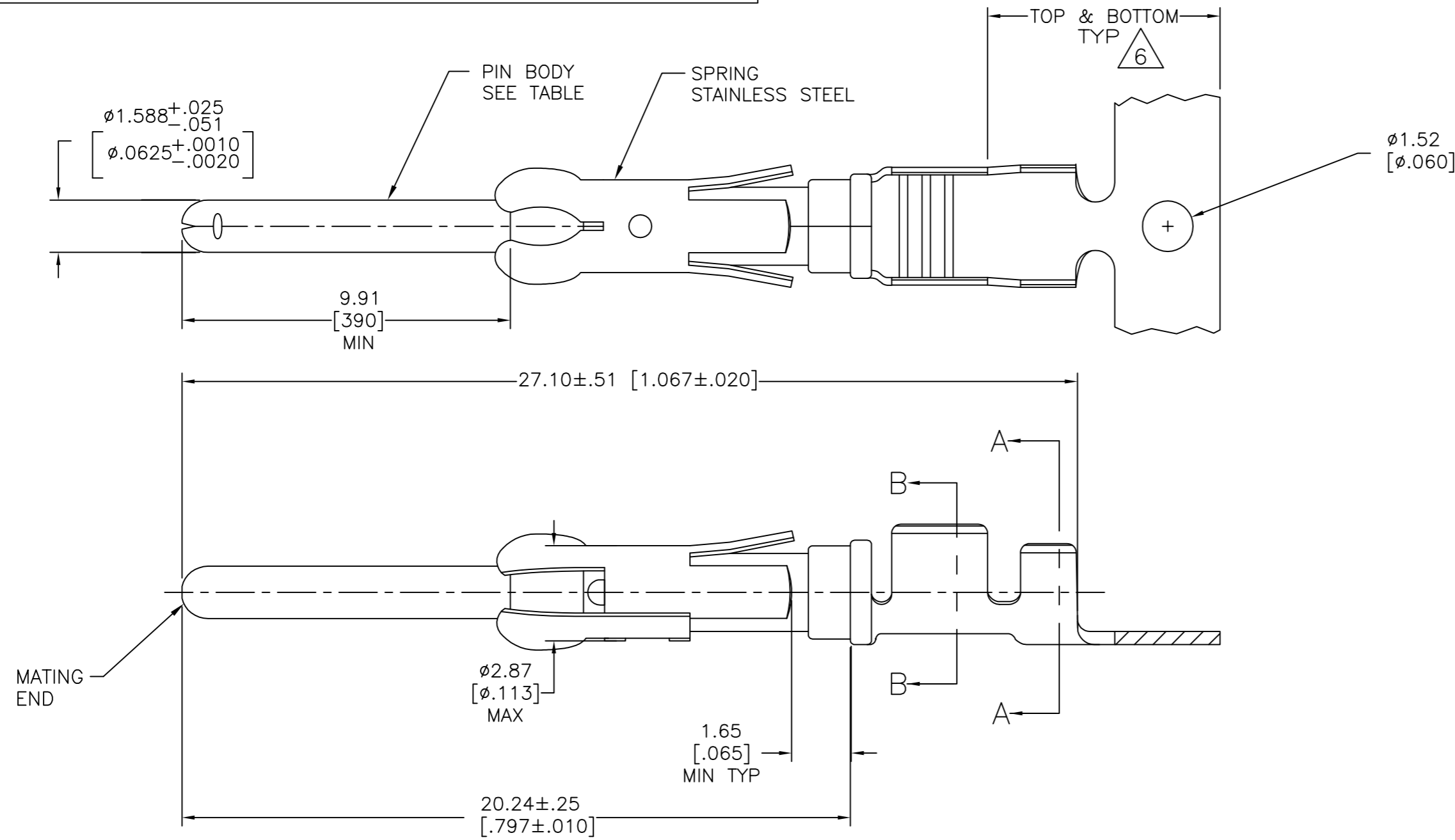

- 1 REVERSE REELED FOR MINI-APPLICATOR.
- 2  $0.76\mu\text{m}$  [.000030] MIN PRECIOUS METAL PLATE ON MATING END FOR A LENGTH OF 5.08 [.200] MIN OVER  $1.27\mu\text{m}$  [.000050] MIN NICKEL. GOLD FLASH ALL OVER. CONFORMS TO THE REQUIREMENTS OF TE CONNECTIVITY PRODUCT SPEC 108-10042, BASED ON EIA/ECA-364-1000.01 ( CONTROLLED ENVIRONMENT APPLICATIONS ),
- 3  $0.76\mu\text{m}$  [.000030] MIN PRECIOUS METAL PLATE ON MATING END FOR A LENGTH OF 5.08 [.200] MIN WITH A UNIFORM GRADIENT TO  $0.25\mu\text{m}$  [.000010] MIN ON REMAINDER, OVER  $1.27\mu\text{m}$  [.000050] MIN NICKEL PLATE. GOLD FLASH ALL OVER. CONFORMS TO THE REQUIREMENTS OF TE CONNECTIVITY PRODUCT SPEC 108-10042, BASED ON EIA/ECA-364-1000.01 ( CONTROLLED ENVIRONMENT APPLICATIONS ).
- 4  $0.38\mu\text{m}$  [.000015] MIN GOLD PER MIL-G-45204 ON MATING END FOR A LENGTH OF 5.08 [.200] MIN WITH  $1.27\mu\text{m}$  [.000050] MATTE TIN PLATE IN WIRE CRIMP AREA, BOTH OVER  $1.27\mu\text{m}$  [.000050] MIN NICKEL PER QQ-N-290.
- 5  $1.27\mu\text{m}$  [.000050] MIN TIN-LEAD PER MIL-T-10727 OVER  $1.27\mu\text{m}$  [.000050] MIN NICKEL PER QQ-N-290.
- 6 GOLD PLATING NEED NOT APPEAR IN THIS AREA.
- 7 WIRE RANGE 18-14 AWG.
- 8 INSULATION RANGE 2.03[.080]-2.54[.100] DIA.
- 9  $0.38\mu\text{m}$  [.000015] MIN GOLD PER MIL-G-45204 ON MATING END FOR A LENGTH OF 5.08 [.200] MIN,  $1.27\mu\text{m}$  [.000050] MIN TIN-LEAD PER MIL-T-10727 FOR A LENGTH OF 5.69 [.224] MIN ON OPPOSITE END, BOTH OVER  $1.27\mu\text{m}$  [.000050] MIN NICKEL PER QQ-N-290 ON ENTIRE CONTACT.
- 10  $1.27\mu\text{m}$  [.000050] MIN TIN PER MIL-T-10727 OVER  $1.27\mu\text{m}$  [.000050] MIN NICKEL PER QQ-N-290.
- 11  $2.54\mu\text{m}$  [.000100] MIN SILVER OVER  $0.76\mu\text{m}$  [.000030] MIN NICKEL PER QQ-N-290
- 12  $0.76\mu\text{m}$  [.000030] MIN PRECIOUS METAL PLATE ON MATING END FOR A LENGTH OF 5.08 [.200] MIN WITH  $1.27\mu\text{m}$  [.000050] MATTE TIN PLATE IN WIRE CRIMP AREA, BOTH OVER  $1.27\mu\text{m}$  [.000050] NICKEL PLATE. CONFORMS TO THE REQUIREMENTS OF TE CONNECTIVITY PRODUCT SPEC 108-10042, BASED ON EIA/ECA-364-1000.01A ( CONTROLLED ENVIRONMENT APPLICATIONS ).

OBSOLETE	1	11	BRASS	-	2-66359-0
	1	10	CU-NI ALLOY	1-66361-6	1-66359-9
	STANDARD	10	BRASS	1-66361-2	1-66359-8
	1	5	CU-NI ALLOY	1-66361-5	1-66359-7
	1	2	CU-NI ALLOY	1-66361-4	1-66359-6
	1	10	PHOSPHOR BRONZE	-	1-66359-5
	1	10	BRASS	1-66361-2	1-66359-4
OBSOLETE	1	9	BRASS	66361-9	1-66359-3
	1	2	PHOSPHOR BRONZE	66361-8	1-66359-2
	1	5	PHOSPHOR BRONZE	66361-7	1-66359-1
	1	12	BRASS	66361-4	1-66359-0
	1	4	BRASS	66361-3	66359-9
	1	5	BRASS	66361-2	66359-6
	1	3	BRASS	66361-1	66359-5
	STANDARD	12	BRASS	66361-4	66359-4
	STANDARD	4	BRASS	66361-3	66359-3
	STANDARD	5	BRASS	66361-2	66359-2
	STANDARD	3	BRASS	66361-1	66359-1
	REELING	PIN BODY FINISH	PIN BODY	LOOSE PIECE REF	PART NO

THIS DRAWING IS A CONTROLLED DOCUMENT.

DWN: V. FURLER 23JUL2003  
 CHK: G. STEINHAUER 24JUL03  
 APVD: G. STEINHAUER 24JUL03

TE Connectivity

PIN ASSEMBLY, .062, TYPE III+

SIZE: A2 CAGE CODE: 00779 DRAWING NO: C=66359 RESTRICTED TO: -

MATERIAL: SEE CALLOUTS TOLERANCES UNLESS OTHERWISE SPECIFIED: SEE TABLE WEIGHT: - SCALE: NTS SHEET: 1 OF 1 REV: AF