



NEW!

Flyback Transformer

For ON Semiconductor
NCP1606 PFC Controller



- Designed for 90 Watt applications
- Operates in discontinuous conduction mode with an input of 85 – 265 Vac, 1.28 Arms maximum
- 3000 Vrms isolation from primary and auxiliary to secondary

Core material Ferrite

Terminations RoHS compliant tin-silver over tin over copper. Other terminations available at additional cost.

Weight 68 g

Ambient temperature -40°C to +125°C

Storage temperature Component: -40°C to +125°C.
Packaging: -40°C to +80°C

Moisture Sensitivity Level (MSL) 1 (unlimited floor life at <30°C / 85% relative humidity)

Failures in Time (FIT) / Mean Time Between Failures (MTBF)
38 per billion hours / 26,315,789 hours, calculated per Telcordia SR-332

Packaging 30 parts per tray

PCB washing Only pure water or alcohol recommended

Part number	Inductance at 0 A ¹ ±10% (µH)	Inductance at I _{pk} ² (µH)	DCR max (Ohms) ³			Leakage inductance max (µH)	Turns ratio ⁴		I _{pk} ² (A)	Output ⁵
			pri	aux	sec		pri : aux	pri : sec		
GA3366-BL	300	270	0.180	0.073	0.0053	7.45	1 : 0.118	1 : 0.147	3.3	19.5 V, 4.62 A

1. Inductance measured at 100 kHz, 1.1 Vrms, 0 Adc using an Agilent/ HP 4263B impedance analyzer or equivalent.
 2. Peak primary current drawn at minimum input voltage.
 3. DCR for the secondary is with the windings connected in parallel.
 4. Turns ratio is with the secondary windings connected in parallel.
 5. Output of the auxiliary winding is 16 V, 20 mA.
 6. Electrical specifications at 25°C.
- Refer to Doc 362 "Soldering Surface Mount Components" before soldering.

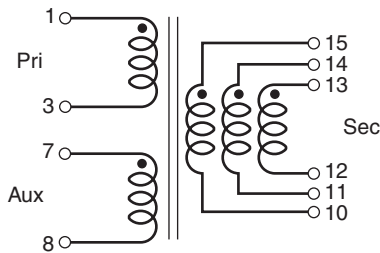

Secondary windings to be connected in parallel on the PC board

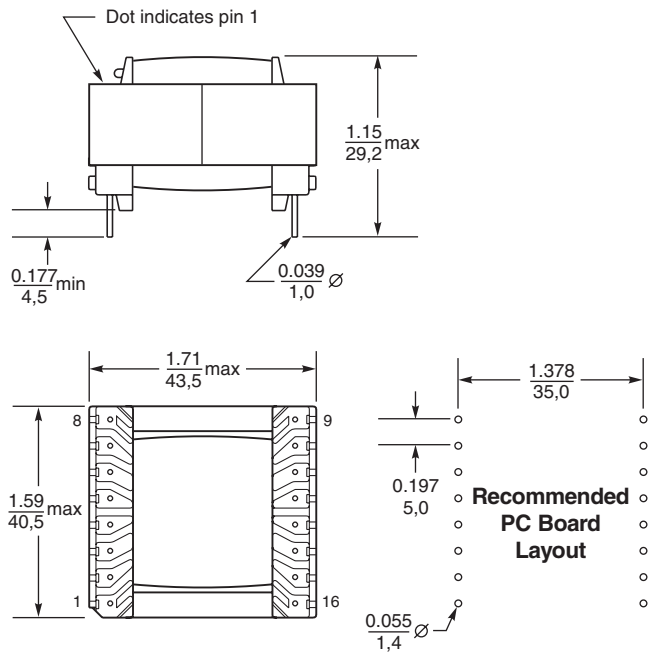

Dimensions are in $\frac{\text{inches}}{\text{mm}}$



Specifications subject to change without notice.
Please check our website for latest information.

Document 656 Revised 01/20/09

1102 Silver Lake Road Cary, Illinois 60013 Phone 847/639-6400 Fax 847/639-1469

E-mail info@coilcraft.com Web <http://www.coilcraft.com>