

THIS DRAWING IS UNPUBLISHED. RELEASED FOR PUBLICATION 20
 © COPYRIGHT 20 BY - ALL RIGHTS RESERVED.

REVISIONS					
P	LTR	DESCRIPTION	DATE	DWN	APVD
A		RELEASED PER ECO-15-013901	21SEP2015	RLK	MM
B		REVISED PER ECO-16-007344	08JUN2016	RLK	MM

1 MATERIAL:
 CONNECTOR HOUSING: UL94 V-0 RATED THERMOPLASTIC, COLOR: GRAY
 LATCH: THERMOPLASTIC, COLOR: BLACK
 CABLE JACKET: THERMOPLASTIC ELASTOMER, COLOR: BLACK
 CABLE CONDUCTORS: COPPER ALLOY
 CONNECTOR CONTACTS: BRASS ALLOY

2 FINISH:
 CONNECTOR CONTACTS: SILVER OVER NICKEL

3 CHARGING CABLE: TE CONNECTIVITY PROPRIETARY,
 UL LISTING: TYPE EVE
 CABLE COLOR, LENGTH AND WIRE TERMINATIONS ARE FULLY CUSTOMIZABLE

4. EV CONNECTOR TECHNICAL PARAMETERS:
 CURRENT, 32A, VOLTAGE, 240 VAC
 INGRESS PROTECTION, IP66
 STATIC RESISTANCE
 (FROM PROX. DETECTION TO GROUND) 150ohm
 RESISTANCE WILL INCREASE TO 480ohm WHEN LATCH IS DEPRESSED

5. THIS PRODUCT IS DESIGNED IN ACCORDANCE WITH SAE INTERNATIONAL SPECIFICATION J1772

6 CENTER LINE OF VEHICLE INLET

7 LATCH IS SHOWN IN LOCKED POSITION

8. THIS PRODUCT IS RoHS COMPLIANT

9. UL RECOGNITION UNDER E349950

10 THE FOLLOWING INFORMATION IS MARKED ON THE CONNECTOR KEY: TE LOGO, TE PART NUMBER, REVISION, DATE CODE (YYWW) AND UL COMPONENT MARK IN NORTH AMERICA

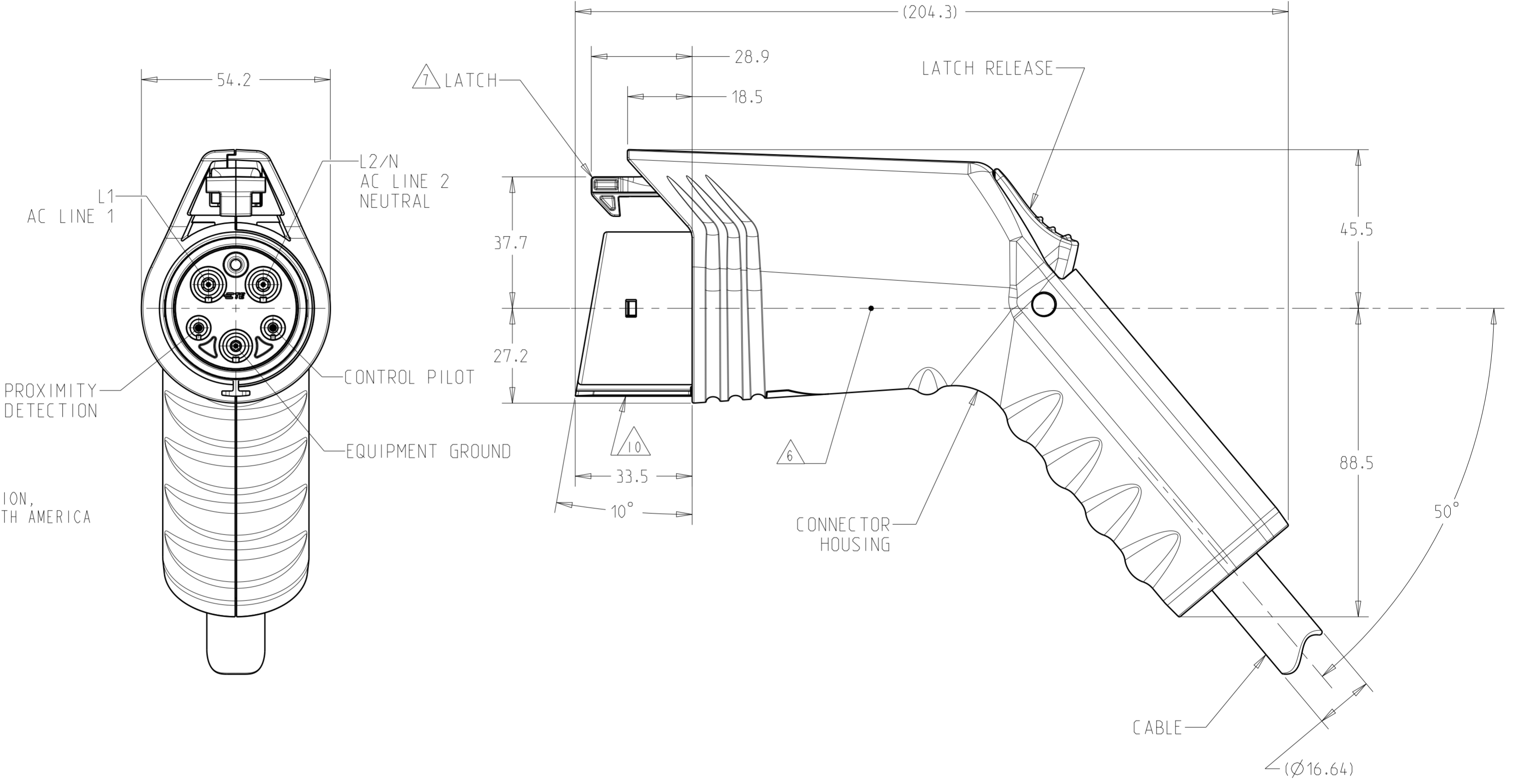

3	7.62m (25 FT)	2267220-4
	6.1m (20 FT)	2267220-3
	4.6m (15 FT)	2267220-2
	3.05m (10 FT)	2267220-1
CABLE	CABLE LENGTH	PART NUMBER

THIS DRAWING IS A CONTROLLED DOCUMENT.

DIMENSIONS:	TOLERANCES UNLESS OTHERWISE SPECIFIED:	DWN	24APR2015	TE Connectivity
mm	0 PLC ±	CHK	24APR2015	
	1 PLC ±0.4	APVD	25SEP2015	
	2 PLC ±	NAME	G. DEFI BAUGH	
	3 PLC ±	PRODUCT SPEC	108-32100	
	4 PLC ±	APPLICATION SPEC	-	
	ANGLES ±2°	WEIGHT	-	
	FINISH	Customer Drawing	SCALE 1:1	

SIZE	CAGE CODE	DRAWING NO	RESTRICTED TO
A2	00779	C-2267220	-
SHEET	OF	REV	B