

THIS DRAWING IS UNPUBLISHED.

RELEASED FOR PUBLICATION

20

© COPYRIGHT 20 BY -

ALL RIGHTS RESERVED.

REVISIONS

P	LTR	DESCRIPTION	DATE	DWN	APVD
	A	INITIAL	03MAR2016	BS	CW

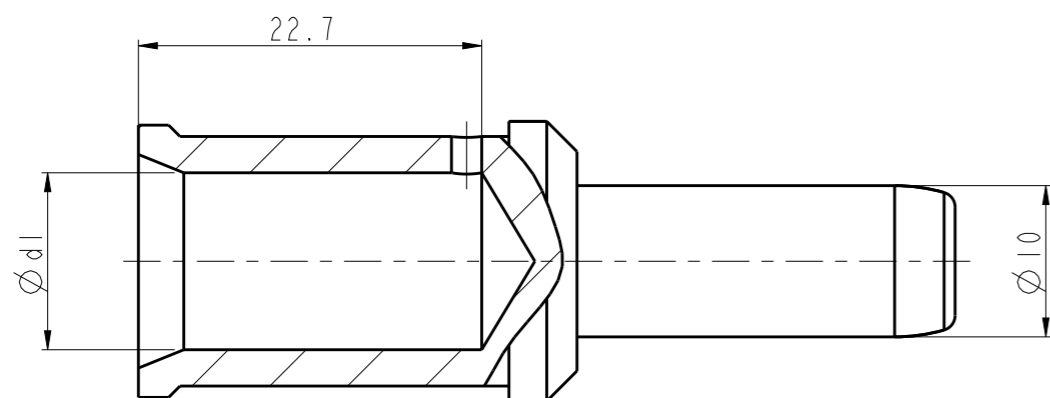
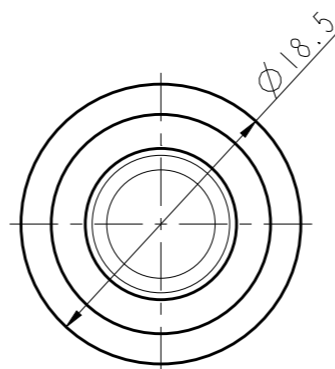
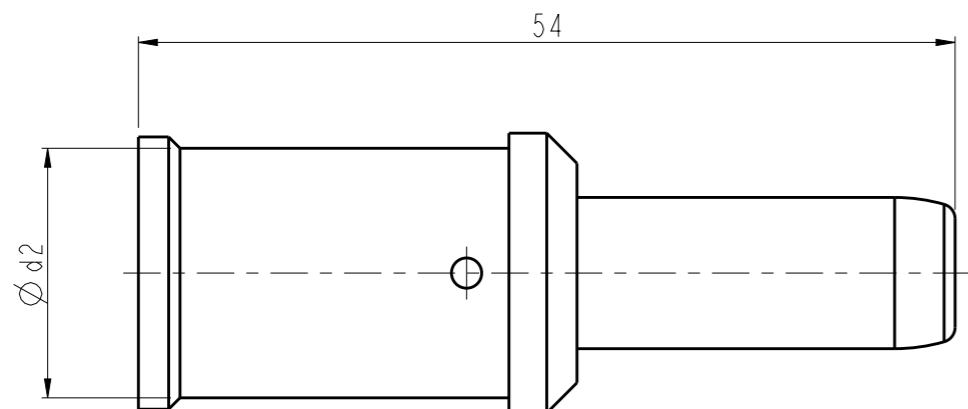
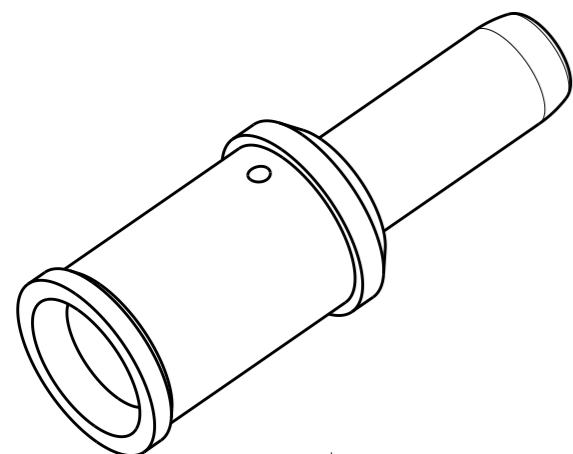

NOTES:

- 1. TECHNICAL CHARACTERISTICS:
CONTACT MATERIAL: COPPER
SURFACE PLATING: SILVER PLATING
WIRE RANGE: 35-70 mm² (2-2/0 AWG)

注释:

- 1. 技术参数:
针件材料: 铜合金
表面电镀: 镀银
接线范围: 35-70 mm² (2-2/0 AWG)

PIN CONTACT 公针	PART NUMBER AFTER PLATING 电镀后料号		$\phi d1$	$\phi d2$	SURF AREA (mm ²) 表面积	WIRE GAUGE		STRIPPING LENGTH 剥线长度 (mm)
	PART NUMBER 料号	DESCRIPTION 型号				mm ²	AWG	
	T2192501035-000	HCM250-MC-35	8.4	12.5	3285.71	35	2	22
	T2192501050-000	HCM250-MC-50	10.2	14.5	3480.79	50	1/0	22
	T2192501070-000	HCM250-MC-70	11.7	16.5	3653.68	70	2/0	22

THIS DRAWING IS A CONTROLLED DOCUMENT.

DWN BELL SU 03MAR2016

CHK KYLE ZENG 03MAR2016

APVD CHRIS WANG 03MAR2016

PRODUCT SPEC 108-137171

APPLICATION SPEC 114-137171

WEIGHT -

CUSTOMER DRAWING



TE Connectivity

NAME
HCM250
PIN CONTACT

SIZE A3 CAGE CODE - DRAWING NO. ©-T21925010XX000 RESTRICTED TO -

SCALE 2:1 SHEET 1 OF 1 REV A

DIMENSIONS:

mm

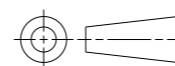

TOLERANCES UNLESS OTHERWISE SPECIFIED:

0 PLC	±-
1 PLC	±-
2 PLC	±-
3 PLC	±-
4 PLC	±-
ANGLES	±-

MATERIAL -

FINISH -