



MOP-TFT320240-35A-BLM-TPC

Hardware Manual

Revision 1.0

Revision History

| Revision | Date | Description | Author |
|----------|--------------|-----------------|--------|
| 1.0 | May 26, 2017 | Initial Release | Divino |



Contents

- Revision History 1
- Contents 2
- 1 General Information 3
- 2 Absolute Maximum Ratings..... 3
- 3 Electrical Characteristics..... 3
- 4 Backlight Characteristics..... 3
- 5 Touch Panel Characteristics 4
- 6 External Dimensions 5
- 7 Electro-Optical Characteristics 6
- 8 Interface Description 7
 - 8.1 LCM Interface Description 7
 - 8.2 CTP Interface Description 7
- 9 AC Characteristics 8
 - 9.1 Pixel Timing..... 8
 - 9.2 Data Timing..... 9
- 10 Power Sequence 10
 - 10.1 Power Up Sequence 10
 - 10.2 Power Down Sequence..... 11
- 11 Inspection Criterion 12
 - 11.1 Description 12
 - 11.2 Sample plan 12
 - 11.3 Inspection condition 12
 - 11.4 Definition of inspection zone in LCD..... 12
 - 11.5 Function Defect 12
 - 11.6 LCD pixel defect 13
 - 11.7 Dot and line defect 13
- 12 Handling Precautions..... 14
 - 12.1 Mounting method 14
 - 12.2 LCD Handling and Cleaning Precaution 14
 - 12.3 Static Charge Precaution 14
 - 12.4 Packing..... 14
 - 12.5 Precautions during Operation 14
 - 12.6 Storage Recommendations 15
 - 12.7 Safety Precautions 15
- 13 Ordering 16
 - 13.1 Part Numbering Scheme..... 16
 - 13.2 Options 16
- 14 Contact 16



1 General Information

| No. | Item | Contents | Unit |
|-----|--------------------------------|--------------------------------|------|
| 1 | LCD size | 3.5 inch (Diagonal) | / |
| 2 | LCD type | TN/Normally white/Transmissive | / |
| 3 | Viewing direction(eye) | 12 O'clock | / |
| 4 | Gray scale inversion direction | 6 O'clock | / |
| 5 | Resolution(H*V) | 320*240 Pixels | / |
| 6 | Module size (L*W*H) | 76.9*63.9*5.1 | mm |
| 7 | Active area (L*W) | 70.08*52.56 | mm |
| 8 | Pixel pitch (L*W) | 0.219*0.219 | mm |
| 9 | Interface type | RGB interface | / |
| 10 | Module power consumption | 0.066(without backlight) | W |
| 11 | Back light type | LED | / |
| 12 | Driver IC | HX8238D or compatible | / |
| 13 | Weight | 49 | g |

2 Absolute Maximum Ratings

| Item | Symbol | Min | Max | Unit |
|----------------------------------|--------|------|---------------|------|
| Power supply input voltage (LCM) | VDD | -0.3 | 3.6 | V |
| Backlight current (normal temp.) | ILED | - | 50 | mA |
| Operation temperature | Top | -20 | 70 | °C |
| Storage temperature | Tst | -30 | 80 | °C |
| Humidity | RH | - | 90%(Max60 °C) | RH |

3 Electrical Characteristics

DC Characteristics (at Ta=25 °C)

| Item | Symbol | Min | Typ | Max | Unit |
|--|--------|--------|-----|--------|------|
| Power supply input voltage (LCM) | VDD | 2.5 | 3.3 | - | V |
| I/O logic voltage | VDDIO | N/A | N/A | N/A | V |
| Input voltage 'H' level | VIH | 0.7VDD | - | VDD | V |
| Input voltage 'L' level | VIL | VSS | - | 0.3VDD | V |
| Power supply current | IVDD | - | 20 | - | mA |
| TFT gate on voltage | VGH | - | N/A | - | V |
| TFT gate off voltage | VGL | - | N/A | - | V |
| Analog power supply voltage | AVDD | - | N/A | - | V |
| Differential input common mode voltage | Vcom | - | N/A | - | V |

4 Backlight Characteristics

(at Ta=25 °C, RH=60%)

| Item | Symbol | Min. | Typ. | Max. | Unit | Note |
|-----------------------|--------|----------------------------|-------|------|------|-----------|
| LED forward voltage | VF | - | 9.6 | 10.2 | V | IF=20*2mA |
| LED forward current | IF | - | 40 | - | mA | |
| LED power consumption | PLED | - | 0.384 | - | W | *Note |
| Number of LED | - | 6 | | | PCS | |
| Connection mode | - | 3 in series, 2 in parallel | | | / | |
| LED life-time | - | 20000 | - | - | Hrs | **Note |

***Note:** Calculate Value for reference ILED×VLED×LED Quantity = PLED

****Note:** The LED Life-time is defined as the estimated time to 50% degradation of initial brightness at Ta=25°C and IF =40mA. The LED lifetime could be decreased if operating IF is larger than 40mA, and increased if IF is less than 40mA.



5 Touch Panel Characteristics

(at Ta=25 °C)

| Item | Description |
|-------------------------|-----------------|
| IC solution on TP Model | FT5416 |
| Touch Count Max | 5 point |
| Display Resolution* | 320*240 |
| Interface Type * | I2C |
| I2C Slave Address* | 0x70 |
| Origin of Coordinate* | top left corner |

| Parameter | Min | Typ | Max | Unit |
|--------------------------|-----|-----|-----|------|
| Interface Signal Voltage | - | 3.0 | - | V |
| Power Voltage | 2.8 | 3.0 | 3.3 | V |
| Power ripple | - | - | 50 | mV |



6 External Dimensions

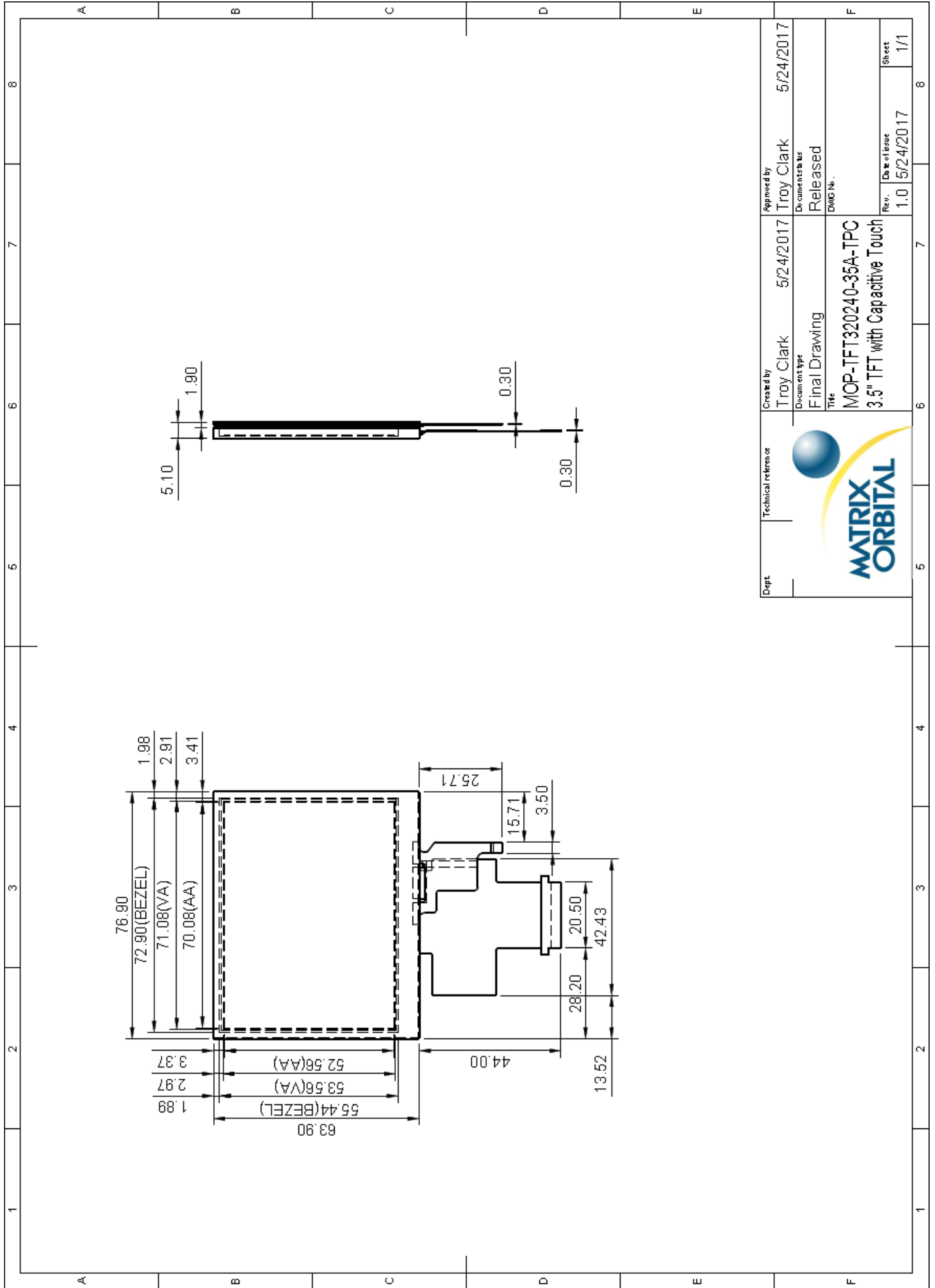

Figure 1: MOP-TFT320240-35A-BLM-TPC Drawing



7 Electro-Optical Characteristics

| Item | Symbol | Condition | Min | Typ | Max | Unit | Remark | Note |
|-------------------------|----------|--|--------|--------|--------|-------------------|-------------------|--------|
| Response time | Tr + Tf | - | - | 50 | 80 | ms | FIG 1. | Note 4 |
| Contrast ratio | Cr | | 200 | 300 | - | --- | FIG 2. | Note 1 |
| Surface luminance | Lv | $\theta=0^\circ$ | 350 | 495 | - | cd/m ² | FIG 2. | Note 2 |
| Luminance uniformity | Yu | $\theta=0^\circ$ | 75 | 80 | - | % | FIG 2. | Note 3 |
| NTSC | - | $\theta=0^\circ$ | - | 60 | - | % | FIG 2. | Note 5 |
| Viewing angle | θ | $\varnothing = 90^\circ$ | 50 | 60 | - | deg | FIG 3. | Note 6 |
| | | $\varnothing = 270^\circ$ | 40 | 50 | - | deg | FIG 3. | |
| | | $\varnothing = 0^\circ$ | 50 | 60 | - | deg | FIG 3. | |
| | | $\varnothing = 180^\circ$ | 50 | 60 | - | deg | FIG 3. | |
| CIE (x, y) chromaticity | Red x | $\theta=0^\circ$ $\varnothing=0^\circ$ Ta=25°C | 0.5706 | 0.6106 | 0.6506 | - | FIG 2. CIE1931 | Note 5 |
| | Red y | | 0.3254 | 0.3654 | 0.4054 | - | | |
| | Green x | | 0.3000 | 0.3400 | 0.3800 | - | | |
| | Green y | | 0.5649 | 0.6049 | 0.6449 | - | | |
| | Blue x | | 0.1074 | 0.1474 | 0.1874 | - | | |
| | Blue y | | 0.0387 | 0.0787 | 0.1187 | - | | |
| | White x | | 0.2632 | 0.3032 | 0.3432 | - | | |
| | White y | | 0.2829 | 0.3229 | 0.3629 | - | | |

***Note 1:** Definition of contrast ratio

Contrast Ratio (CR) is defined mathematically by the following formula.

$$\text{CONTRAST RATIO} = \frac{\text{Luminance measured when LCD on the "White" State}}{\text{Luminance measured when LCD on the "Black" State}}$$

***Note 2:** Definition of surface luminance

Surface luminance is the LCD luminance from the surface with all pixels displaying white.

$$L_v = \text{Average Surface Luminance with all white pixels (P1, P2, P3 ... Pn)}$$

***Note 3:** Definition of luminance uniformity

The luminance uniformity in surface luminance (Yu) is determined by measuring luminance at each test position 1 through n, and then dividing the maximum luminance of n point's luminance by minimum luminance of n points luminance.

$$Y_u = \frac{\text{Minimum Surface Luminance with all white pixels (P1, P2, P3 ... Pn)}}{\text{Maximum Surface Luminance with all white pixels (P1, P2, P3 ... Pn)}}$$

***Note 4:** Definition of Response time

The response time is defined as the LCD optical switching time interval between "White" state and "Black" state. Rise time (TON) is the time between photo detector output intensity changed from 90% to 10%. And fall time (TOFF) is the time between photo detector output intensity changed from 10% to 90%.

***Note 5:** Definition of color chromaticity (CIE1931)

CIE (x, y) chromaticity, the x, y value is determined by screen active area center position P5.

***Note 6:** Definition of Viewing angle.

Viewing angle is the angle at which the contrast ratio is greater than 10. The angles are determined for the horizontal or x axis and the vertical or y axis with respect to the z axis which is normal to the LCD surface.

For Viewing angle and response time testing, the testing data is based on Autronic-Melchers's ConoScope or DMS series Instruments or compatible. For contrast ratio, Surface Luminance, Luminance uniformity and CIE, the testing data is based on TOPCON's BM-7 or BM-5 photo detector or compatible.

***Note 7:** For TFT module, Gray scale reverse occurs in the direction of panel viewing angle.



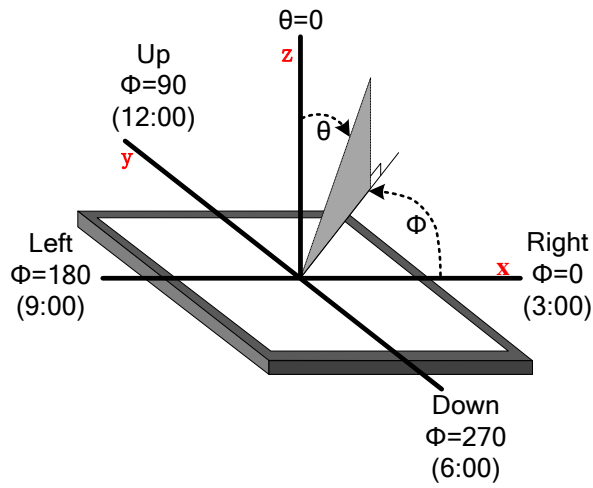

Figure 2: The definition of viewing angle

8 Interface Description

8.1 LCM Interface Description

| Interface No. | Name | I/O Pin Connections | Description |
|---------------|------------|---------------------|----------------------------------|
| 1 | LEDK | P | Power for LED backlight(Cathode) |
| 2 | LEDA | P | Power for LED backlight(Anode) |
| 3 | CS | I | Chip select pin |
| 4 | VDD | P | Power for LCD |
| 5-12 | Red(0-7) | I | Red data |
| 13-20 | Green(0-7) | I | Green data |
| 21-28 | Blue(0-7) | I | Blue data |
| 29 | GND | I | Ground |
| 30 | DCLK | I | Dot-clock signal |
| 31 | DISP | I | Display on/off |
| 32 | HSYNC | I | Horizontal sync input. |
| 33 | VSYNC | I | Vertical sync input |
| 34 | DE | I | Data enable |
| 35 | SCL | I | Clock pin of serial interface |
| 36 | SDA | I/O | Data input pin in serial mode |
| 37 | XR(NC) | - | No connection |
| 38 | YD(NC) | - | No connection |
| 39 | XL(NC) | - | No connection |
| 40 | YU(NC) | - | No connection |

8.2 CTP Interface Description

| Interface No. | Name | I/O Pin Connection | Description |
|---------------|-------|--------------------|------------------------|
| 1 | RESET | I | Reset low |
| 2 | VDD | P | Power Supply of CTP |
| 3 | GND | P | Ground |
| 4 | INT | O | State change interrupt |
| 5 | SCL | I | Serial interface clock |
| 6 | SDA | I/O | Serial interface data |



9 AC Characteristics

9.1 Pixel Timing

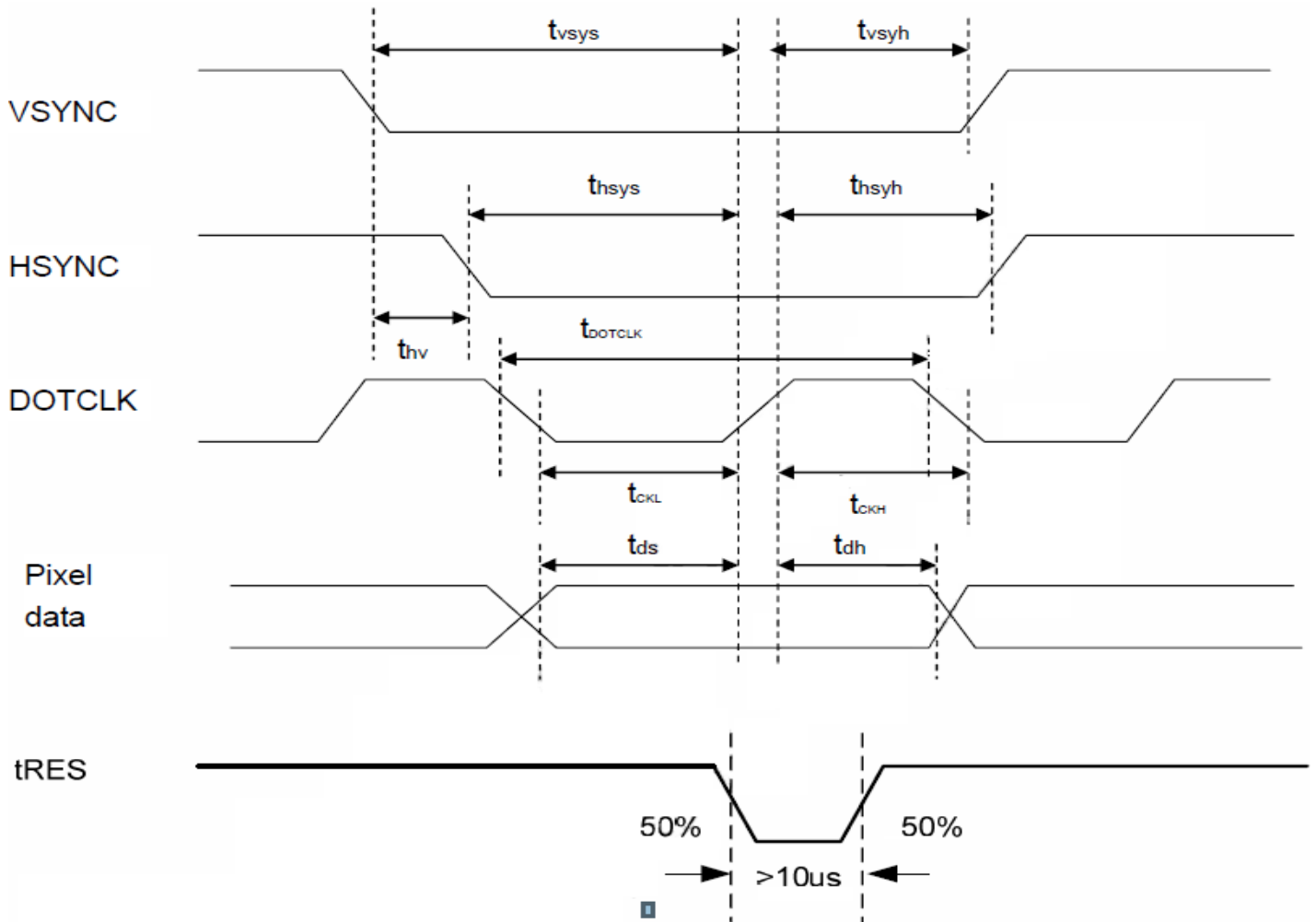

Figure 3: Pixel Timing

| Characteristics | Symbol | Min. | | Typ. | | Max. | | Unit |
|--|---------|--------|-------|--------|-------|--------|-------|---------|
| | | 24 bit | 8 bit | 24 bit | 8 bit | 24 bit | 8 bit | |
| DOTCLK Frequency | fDOTCLK | - | - | 6.5 | 19.5 | 10 | 30 | MHz |
| DOTCLK Period | tDOTCLK | 100 | 33.3 | 154 | 51.3 | - | - | ns |
| Vertical Sync Setup Time | tvsys | 20 | 10 | - | - | - | - | ns |
| Vertical Sync Hold Time | tvsyh | 20 | 10 | - | - | - | - | ns |
| Horizontal Sync Setup Time | thsys | 20 | 10 | - | - | - | - | ns |
| Horizontal Sync Hold Time | thsyh | 20 | 10 | - | - | - | - | ns |
| Phase Difference of Sync Signal Falling Edge | thv | 1 | | - | | 240 | | tDOTCLK |
| DOTCLK Low Period | tCKL | 50 | 15 | - | - | - | - | ns |
| DOTCLK High Period | tCKH | 50 | 15 | - | - | - | - | ns |
| Data Setup Time | tds | 12 | 10 | - | - | - | - | ns |
| Data Hold Time | tdh | 12 | 10 | - | - | - | - | ns |
| Reset pulse width | tRES | 10 | | - | | - | | μs |

*Note: External clock source must be provided to DOTCLK pin of HX8238-D. The driver will not operate if absent of the clocking signal.



9.2 Data Timing

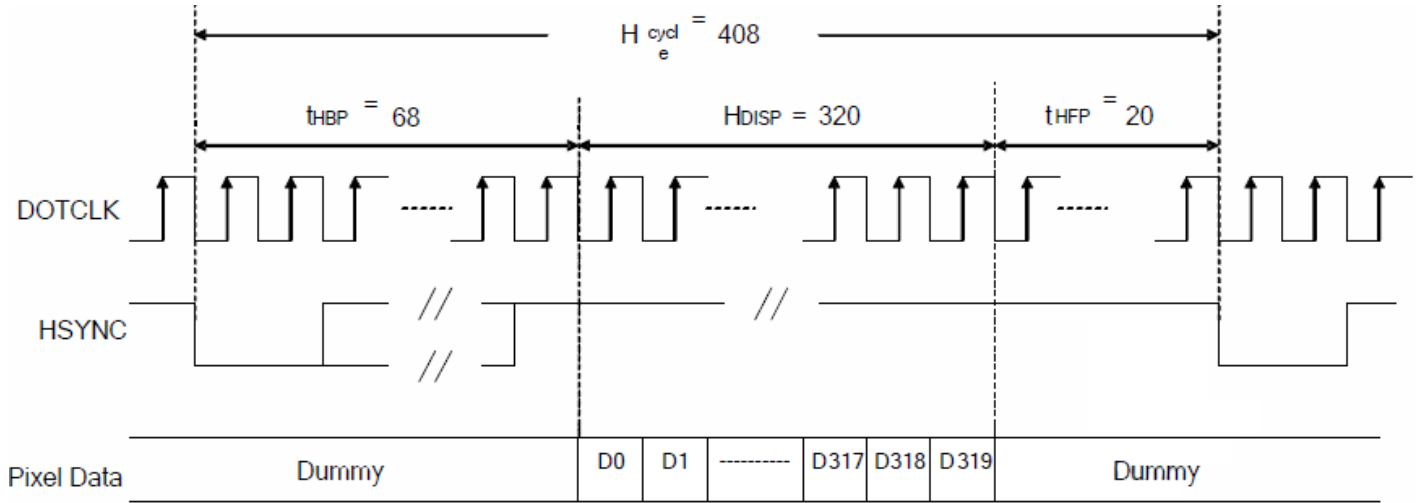

(a) Horizontal Data Transaction Timing

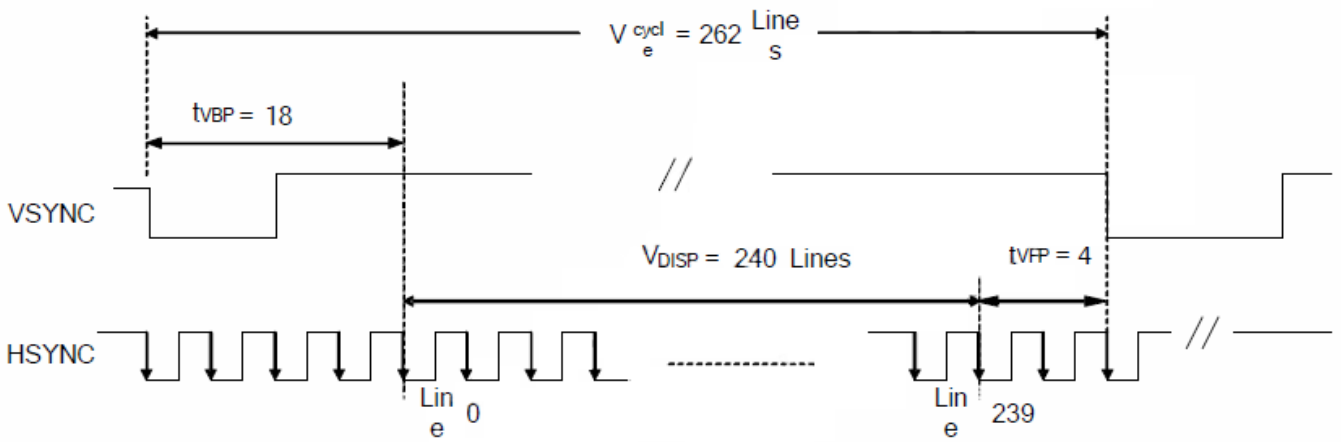

(b) Vertical Data Transaction Timing

Figure 4: Data Transaction Timing in Parallel RGB (24Bit) interface (SYNC Mode)

| Characteristics | Symbol | Min. | | Typ. | | Max. | | Unit |
|------------------------------|-------------|--------|-------|-------------|-------|--------|-------|---------|
| | | 24 bit | 8 bit | 24 bit | 8 bit | 24 bit | 8 bit | |
| DOTCLK Frequency | fDOTCLK | - | - | 6.5 | 19.5 | 10 | 30 | MHz |
| DOTCLK Period | tDOTCLK | 100 | 33.3 | 154 | 51.3 | - | - | ns |
| Horizontal Frequency (Line) | fH | - | - | 14.9 | - | 22.35 | - | KHz |
| Vertical Frequency (Refresh) | fV | - | - | 60 | - | 90 | - | Hz |
| Horizontal Back porch | tHBP | - | - | 68 | 204 | - | - | tDOTCLK |
| Horizontal Front porch | tHFP | - | - | 20 | 60 | - | - | tDOTCLK |
| Horizontal Data Start Point | tHBP | - | - | 68 | 204 | - | - | tDOTCLK |
| Horizontal Blanking Period | tHBP + tHFP | - | - | 88 | 264 | - | - | tDOTCLK |
| Horizontal Display Area | HDISP | - | - | 320 | 960 | - | - | tDOTCLK |
| Horizontal Cycle | Hcycle | - | - | 408 | 1224 | 450 | 1350 | tDOTCLK |
| Vertical Back Porch | tVBP | - | - | 18 | - | - | - | Lines |
| Vertical Front Porch | tVFP | - | - | 4 | - | - | - | Lines |
| Vertical Data Start Point | tVBP | - | - | 18 | - | - | - | Lines |
| Vertical Blanking Period | tVBP + tVFP | - | - | 22 | - | - | - | Lines |
| Vertical Display Area | NTSC | VDISP | - | 240 | | - | - | Lines |
| | PAL | | | 280(PALM=0) | | | | |
| | PAL | | | 288(PALM=1) | | | | |
| Vertical Cycle | NTSC | Vcycle | - | 262 | | 350 | - | Lines |
| | PAL | | | 313 | | | | |



10 Power Sequence

10.1 Power Up Sequence

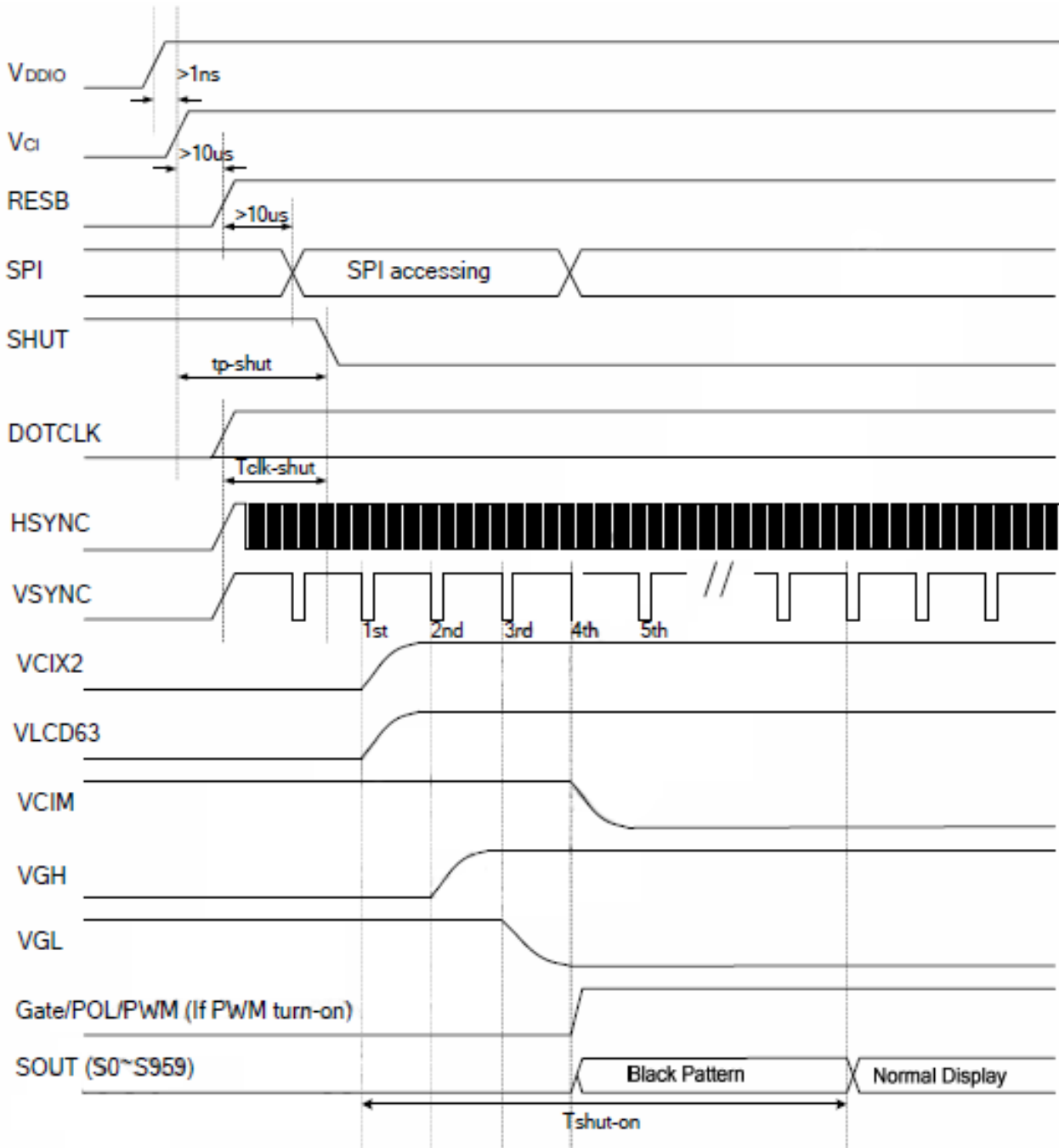

Figure 5: Power Up Sequence

| Characteristics | Symbol | Spec. | | | Unit |
|---|-----------|-------|------|-------|---------|
| | | Min. | Typ. | Max. | |
| VDD/VDDIO on to falling edge of SHUT | tp-shut | 1 | - | - | μs |
| DOTCLK | tclk-shut | 1 | - | - | clk |
| Falling edge of SHUT to display start | tshut-on | - | - | 14 | frame |
| - 1 line: 408 CLK - 1 frame: 262 line - DOTCLK = 6.5MHz | | - | 166 | 232.4 | ms |

***Note:** it is necessary to input DOTCLK before the falling edge of SHUT. Display starts at 10th falling edge of VSYNC after the falling edge of SHUT

10.2 Power Down Sequence

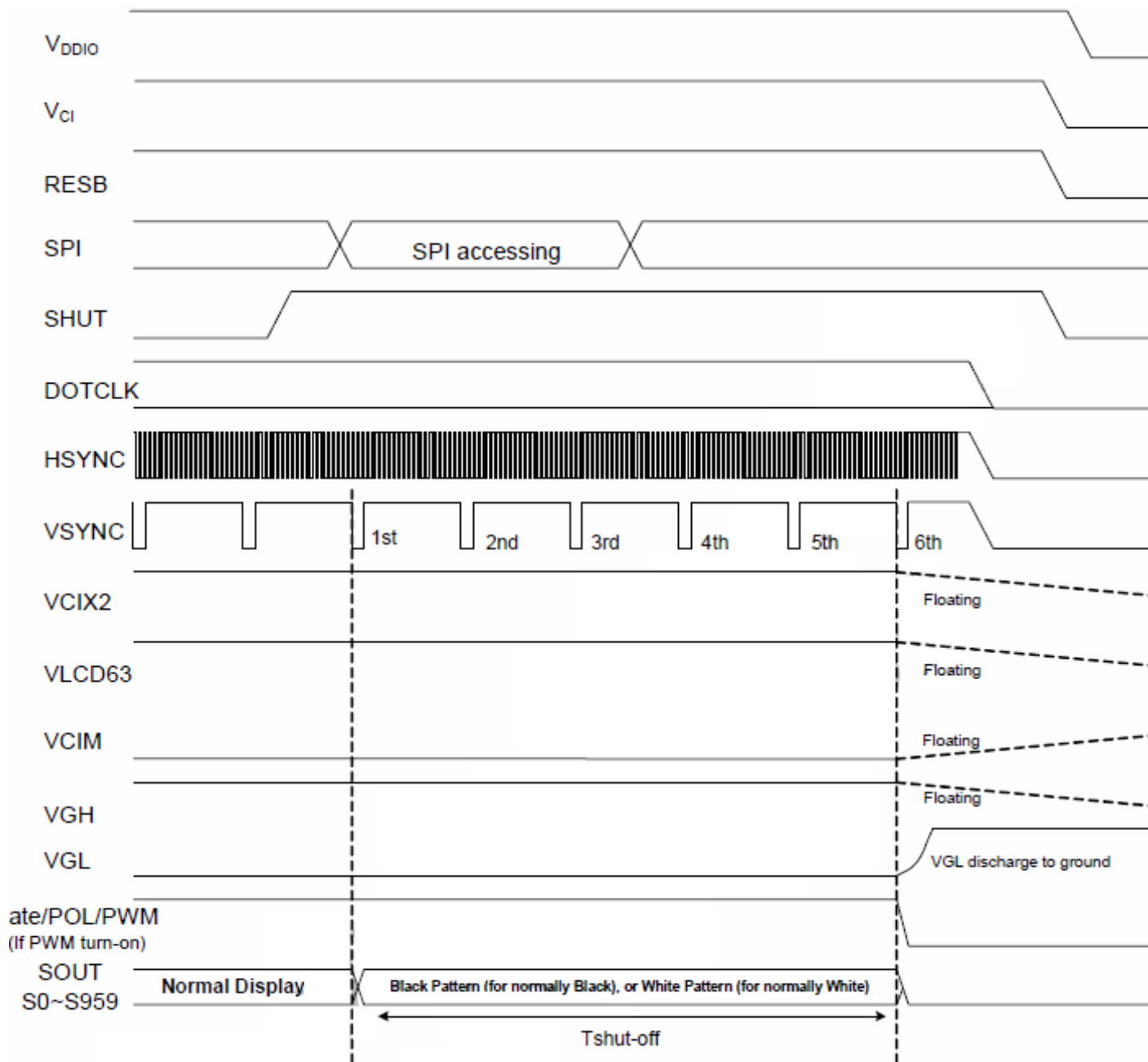

Figure 6: Power Down Sequence

| Characteristics | Symbol | Spec. | | | Unit |
|------------------------------------|-----------|-------|------|------|-------|
| | | Min. | Typ. | Max. | |
| Rising edge of SHUT to display off | tshut-off | 2 | - | - | frame |
| - 1 line: 408 CLK | | 33.4 | - | - | ms |
| - 1 frame: 262 line | | | | | |
| - DOTCLK = 6.5MHz | | | | | |

***Note:** DOTCLK must be maintained at least 2 frames after the rising edge of SHUT. Display turns off at the 2nd falling edge of VSYNC after the falling edge of SHUT. If RESET signal is necessary for power down, provide it after the 2- frames-cycle of the SHUT period.



11 Inspection Criterion

11.1 Description

This specification is made to be used as the standard acceptance/rejection criteria for the MOP-TFT320240-35A-BLM-TPC.

11.2 Sample plan

Sampling plan according to GB/T2828.1-2003/ISO 2859-1: 1999 and ANSI/ASQC Z1.4-1993, normal level 2 and based on:

Major defect: AQL 0.65

Minor defect: AQL 1.5

11.3 Inspection condition

- Viewing distance for cosmetic inspection is about $30\pm 5\text{cm}$ with bare eyes, and under a $600\sim 1000\text{lux}$ environment for visual inspection and $0\sim 200\text{lux}$ for function test. All directions for inspecting the sample should be within 45° against perpendicular line. (Normal temperature $18\sim 28^\circ\text{C}$ and normal humidity $60\pm 15\%\text{RH}$).
- During testing, the LCD is driven using the voltage level (Within $\pm 0.5\text{V}$ of the typical value at 25°C .) that provides the most optical contrast

11.4 Definition of inspection zone in LCD

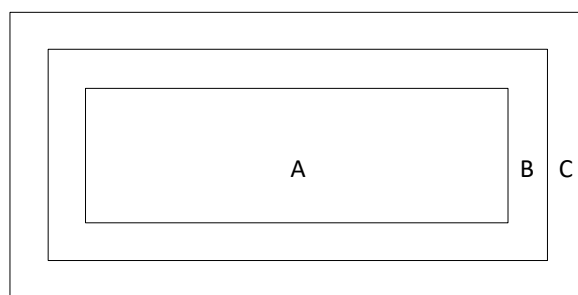

Figure 7: Inspection Zones in an LCD

Zone A: character/Digit area

Zone B: viewing area except Zone A (Zone A + Zone B=minimum Viewing area)

Zone C: Outside viewing area (invisible area after assembly in customer's product)

***Note:** As a general rule, visual defects in Zone C are permissible, if it does not affect display quality and assembly of customer's product.

11.5 Function Defect

| Items to be inspected | Inspection criterion | Classification of defects |
|------------------------|--|---------------------------|
| All functional defects | 1) No display 2) Display abnormally 3) Missing vertical, horizontal segment 4) Short circuit 5) Back-light no lighting, flickering and abnormal lighting. 6) obvious striation 7) Current beyond specification value | MA |
| Missing | Missing component | |
| Outline dimension | Overall outline dimension exceed the drawing is not allowed. | |



11.6 LCD pixel defect

(bad dot) (defect type: MI)

| Checking item | Judgment criterion |
|-------------------------------------|--------------------------------|
| Color bad dot-bright dot(R,G,B) | 1 |
| Two adjacent bright point | 0 |
| Three or more adjacent point | 0 |
| Total points for bad dot-bright dot | 1 |
| Bad dot-dark dot | 2 |
| Two adjacent dark point | 1 |
| Three or more adjacent point | 0 |
| Total points for bad dot -dark dot | 3 |
| Patch bright dot | Invisible with ND5%, it is OK. |

11.7 Dot and line defect

(defect type: MI)

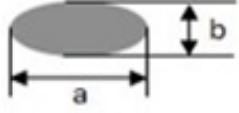
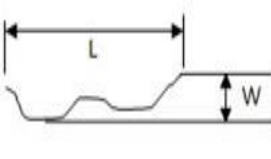
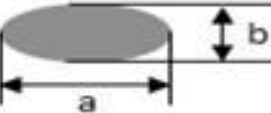
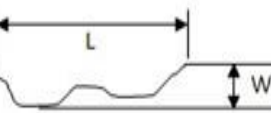
| Checking item | Judgment criterion | | | Figure |
|--|--|---------------|---------------------|--|
| | Diameter(mm)\LCD Size | | S ≤5.0 Inch | |
| Dot defect | D ≤0.1 | | allowed |  $D=(a+b)/2$ |
| | 0.1 < D ≤0.2 | | 4 | |
| | 0.2 < D ≤0.3 | | 0 | |
| | 0.3 < D ≤0.5 | | 0 | |
| | D >0.5 | | 0 | |
| | the distance between the two defect dot: DS ≥5mm | | | |
| Line defect | Length(mm) | Width(mm) | Judgement Criterion |  |
| | disregard | W ≤0.05 | allowed | |
| | L ≤5 | 0.05 < W ≤0.1 | 4 | |
| | L >5 | W >0.1 | 0 | |
| Concave point and air bubble for polarizer | Size(mm) | | Judgement Criterion |  $D=(a+b)/2$ |
| | D ≤0.3 | | allowed | |
| | 0.3 < D ≤1.0 | | 3 | |
| | 1.0 < D ≤1.5 | | 1 | |
| | D >1.5 | | 0 | |
| Fold mark, linear scar for polarizer | Length(mm) | Width(mm) | Judgement Criterion |  |
| | disregard | W ≤0.05 | allowed | |
| | 1 < L ≤5 | 0.05 < W ≤0.2 | 3 | |
| | L >5 | W >0.2 | 0 | |
| | <p>*Notes:</p> <ol style="list-style-type: none"> 1. If the fold mark and linear scar for polarizer is visible with operating condition, the defect is judged with line judge 2. If the fold mark and linear scar for polarizer is visible with non-operating condition, the defect is judged with the above judgment standard. | | | |



12 Handling Precautions

12.1 Mounting method

Do not make extra holes in the display or modify its shape. When mounting the display, ensure that the display does not flex, bend or twist. Extreme care should be used when handling the LCD modules.

12.2 LCD Handling and Cleaning Precaution

To clean the display surface, it is recommended to wipe lightly using a soft cloth with either Isopropyl alcohol or Ethyl alcohol.

Do not wipe the display surface with dry or hard materials as it may damage the polarizer surface.

Do not use Water or Aromatics to clean the display.

Do not wipe ITO pad area with dry or hard materials that will damage the ITO patterns

Do not use Soldering flux, Chlorine(Cl), and Sulfur(S) on the pad or prevent it from being contaminated.

If the display is sent without applying a silicon coat on the pad, the ITO patterns could be damaged due to corrosion as time goes on.

If ITO corrosion occurs due to customer miss-handling, or if the customer applies materials such as Chlorine (Cl), Sulfur (S) to the display, the responsibility is placed the customer.

12.3 Static Charge Precaution

The LCD module uses CMOS LSI drivers, so we recommend that you:

- Connect any unused input terminal to VDD or VSS
- Do not input any signals before power is turned on
- Ground your body, work/assembly areas, and assembly equipment to protect against static electricity.

12.4 Packing

The module employs LCD elements and must be treated as such.

- Avoid intense shock and falls from a height.
- To prevent modules from degradation, do not operate or store them exposed direct to sunshine or high temperature/humidity

12.5 Precautions during Operation

- It is an indispensable condition to drive the LCD module within the specified voltage limits. Applying voltage higher than the limit will reduce the life span of the LCD.
- Using direct drive current should be avoided, as it will induce an electrochemical reaction causing undesirable deterioration.
- The LCD's response time will be delayed when operating at a temperature lower than the suggested operating range. When operating at a temperature higher than the suggested range, the LCD will be noticeably darker. The display will return to normal when it is brought back to the specified operation temperature.
- If the display area is pushed hard during operation, some font may be abnormally drawn but the LCD will return to normal after it is reset.
- Slight dew depositing on terminals can cause an electro-chemical reaction, damaging traces and resulting in an open circuit.

Usage under the maximum operating temperature, 50%Rh or less is required



12.6 Storage Recommendations

When storing the LCD for a prolonged period of time, the following recommendations will help prevent damage or deterioration

- Store the display in an ambient temperature range between 10°C to 30°C, and in a relative humidity of 45% to 75%.
- Do not leave the display exposed to sunlight or fluorescent light.
- Place the display in a polyethylene bag with the opening sealed.
- Ensure that nothing is making contact with the polarizer surface.
- It is recommended to store them in the same packaging that was provided upon purchase

12.7 Safety Precautions

In the case that the LCD glass has shattered, it is recommended to remove any glass pieces, wash off the liquid crystal using either acetone or ethanol, and proceed to burn any remaining display pieces.

If any liquid leaked out of a damaged glass cell, and comes in contact with your hands, please wash it off well with soap and water



13 Ordering

13.1 Part Numbering Scheme

Table 1: Parallel TFT Part Numbering Scheme

| MOP | TFT | 320 | 240 | 35 | A | BLM | TPC |
|-----|-----|-----|-----|----|---|-----|-----|
| 1 | 2 | 3 | 4 | 5 | 6 | 7 | 8 |

13.2 Options

Table 2: Parallel Part Options

| # | Designator | Options |
|---|---------------------|--|
| 1 | Product Line | MOP: Matrix Orbital Parallel Display |
| 2 | Screen Type | TFT: Graphic TFT |
| 3 | Display Columns | 320: Three Hundred Twenty Pixel Columns |
| 4 | Display Rows | 240: Two Hundred Forty Pixel Rows |
| 5 | Display Size | 35: 3.5" |
| 6 | Display Form Factor | A: A Form Factor |
| 7 | Brightness Level | -BLS: Brightness < 300 Nit -BLM: 300 Nit < Brightness < 600 Nit -BLH: 600 Nit < Brightness < 1000 Nit -BLD: Brightness > 1000 Nit |
| 8 | Touch Panel Type | TPN: None TPR: Resistive TPC: Capacitive |

14 Contact

Sales

Phone: 403.229.2737

Email: sales@matrixorbital.ca

Support

Phone: 403.204.3750

Email: support@matrixorbital.ca

Online

Purchasing: www.matrixorbital.com

Support: www.matrixorbital.ca

