

A

B

C

D

E

F

A

B

C

D

E

F

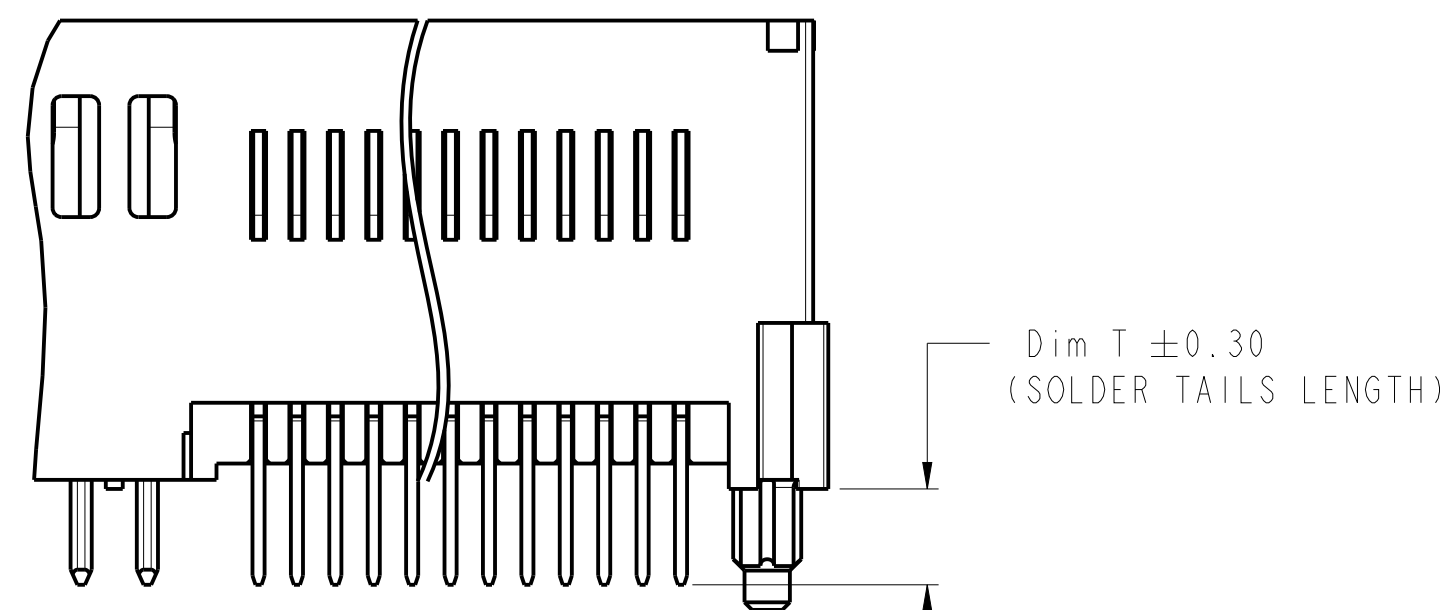
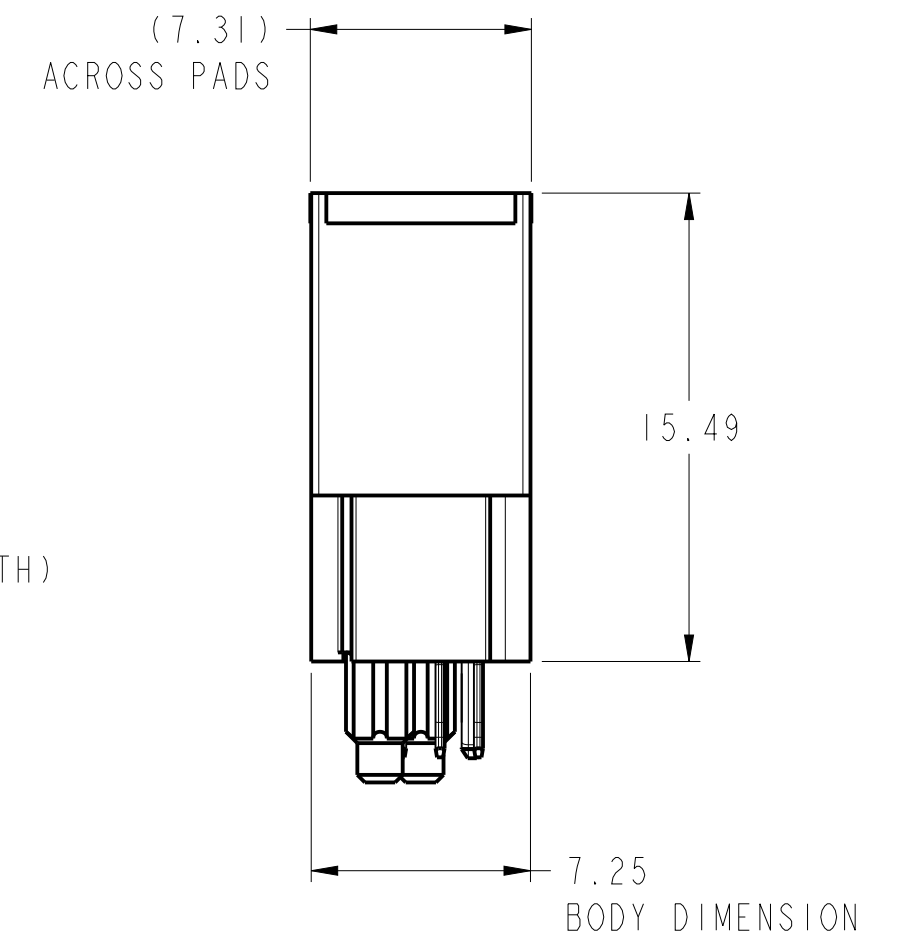
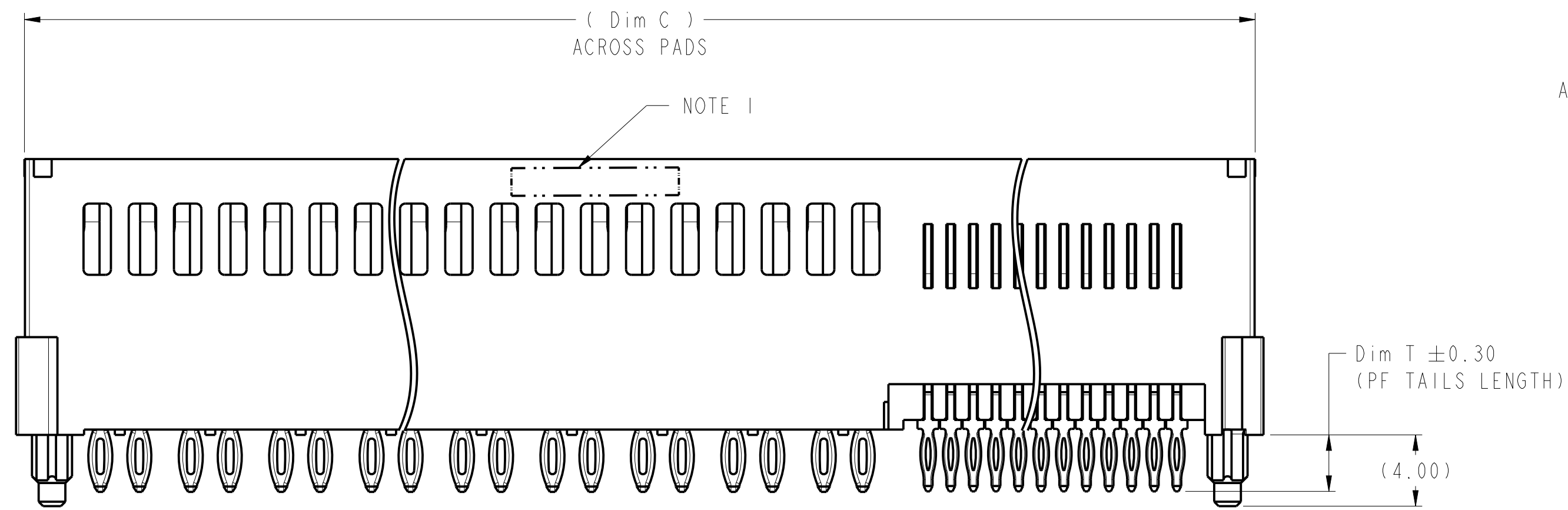
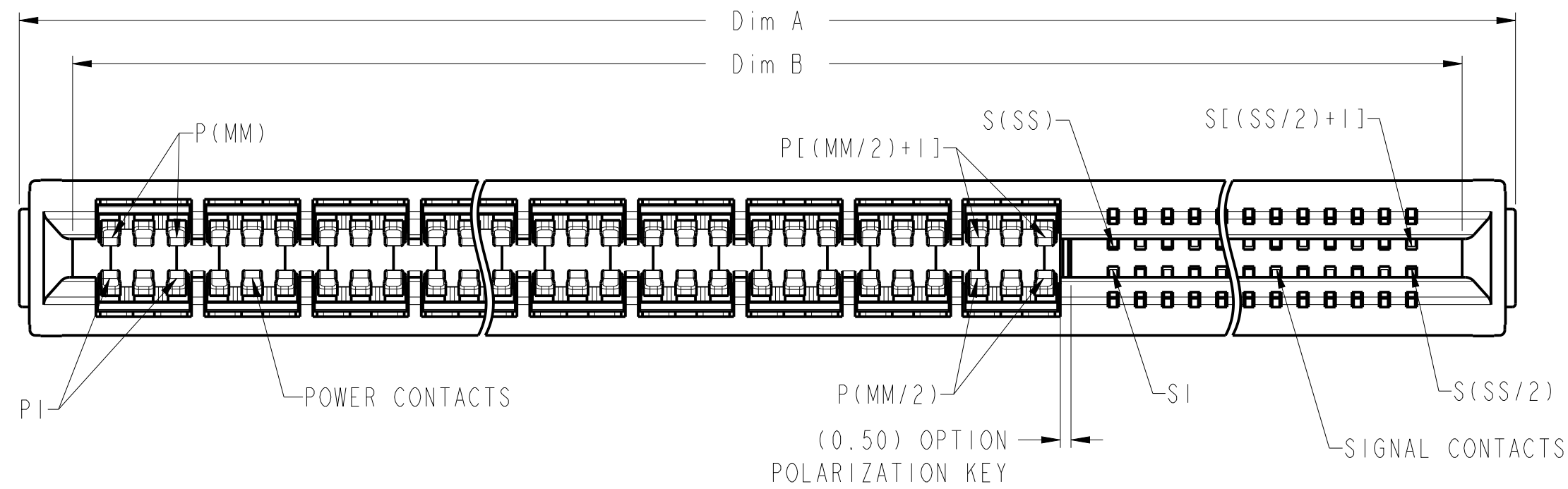

| | | | | | | | | | | |
|---------------------------------------|---------------------|------|-------------|---------------------|---|----|----------|------------------------|--------------|-----|
| spec ref | - | dr | Andy Lu | 2017-10-24 | projection | MM | size | A2 | scale | 5:1 |
| tolerance std | ISO 406 ISO 1101 | eng | Andy Lu | 2017-10-24 | | | ecn no | rel level | In Work | rev |
| TOLERANCES UNLESS OTHERWISE SPECIFIED | | chr | Fancy Zhong | 2017-10-24 | | | | | | |
| surface | linear | 0.X | ±0.5 | Amphenol FCI | eHPCE VERTICAL RECEPTACLE UNIVERSAL DRAWING, MP+S CONFIGURATION | | cat. no. | Product - Customer Drw | sheet 1 of 4 | |
| | | 0.XX | ±0.25 | | | | | | | |
| | angular | 0° | ±2° | | | | | | | |

Amphenol FCI

© 2016 APCI

| CONTACT TYPE | TOP LAYER DESCRIPTION | TABLE 1 (eHPCE / PRESS-FIT TAILS) PLATED THROUGH-HOLE REQUIREMENTS | | | | |
|--------------|-----------------------|---|------------------|--------------------|---------------|------------------------|
| | | DRILLED HOLE DIAMETER | COPPER THICKNESS | TIN-LEAD THICKNESS | TIN THICKNESS | FINISHED HOLE DIAMETER |
| SIGNAL | IMMERSION TIN | 0.81-0.86 (0.85 DRILL) | 0.025 - 0.050 | -- | 0.9 - 1.5um | 0.70 - 0.80 |
| | COPPER | 0.81-0.86 (0.85 DRILL) | 0.025 - 0.050 | -- | -- | 0.70 - 0.80 |
| POWER | IMMERSION TIN | 1.21-1.26 (1.25 DRILL) | 0.025 - 0.050 | -- | 0.9 - 1.5um | 1.10 - 1.20 |
| | COPPER | 1.21-1.26 (1.25 DRILL) | 0.025 - 0.050 | -- | -- | 1.10 - 1.20 |

| CONTACT TYPE | TOP LAYER DESCRIPTION | TABLE 2 (eHPCE / SOLDER TAILS) PLATED THROUGH-HOLE REQUIREMENTS | | | | |
|--------------|-----------------------|--|------------------|--------------------|---------------|------------------------|
| | | DRILLED HOLE DIAMETER | COPPER THICKNESS | TIN-LEAD THICKNESS | TIN THICKNESS | FINISHED HOLE DIAMETER |
| SIGNAL | IMMERSION TIN | 0.96-1.01 (1.00 DRILL) | 0.025 - 0.050 | -- | 0.9 - 1.5um | 0.85 - 0.95 |
| | COPPER | 0.96-1.01 (1.00 DRILL) | 0.025 - 0.050 | -- | -- | 0.85 - 0.95 |
| POWER | IMMERSION TIN | 1.21-1.26 (1.25 DRILL) | 0.025 - 0.050 | -- | 0.9 - 1.5um | 1.10 - 1.20 |
| | COPPER | 1.21-1.26 (1.25 DRILL) | 0.025 - 0.050 | -- | -- | 1.10 - 1.20 |

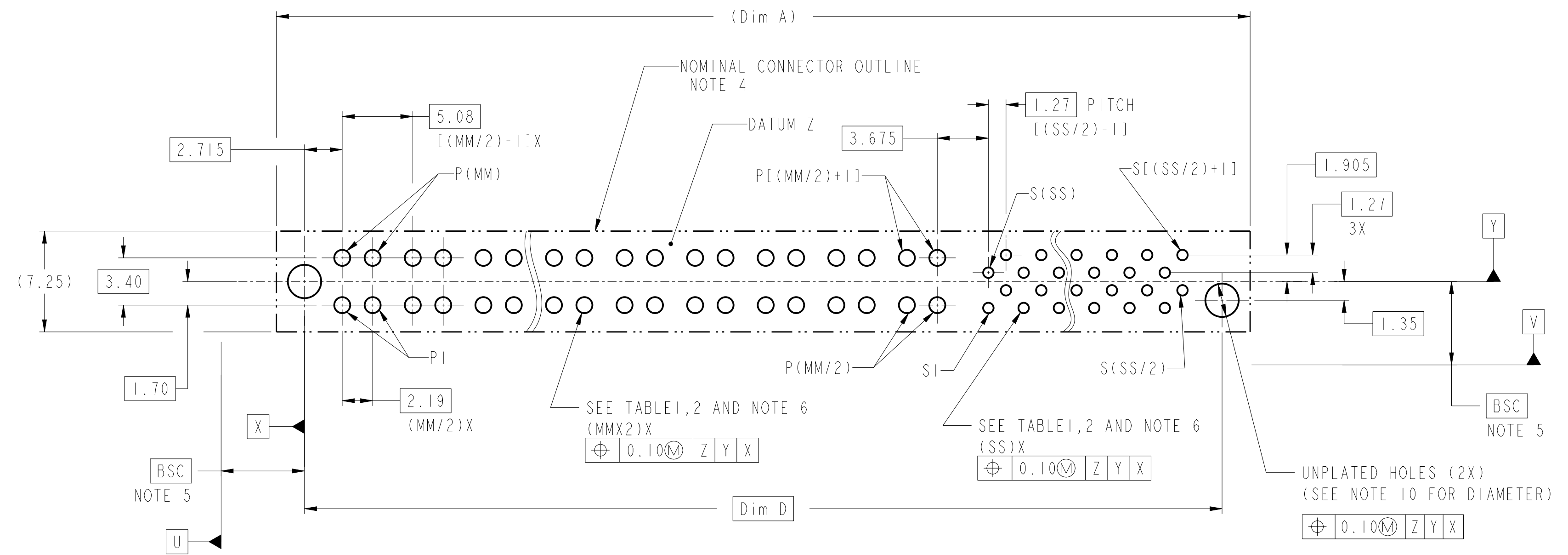

**RECOMMENDED HOST BOARD LAYOUT
(DIMENSION TOLERANCE IS ±0.05mm)**

| | | | | | | | | | | |
|---------------------------------------|---------------------|--------------|----------------|---------------------------------------|----------------|------------------------|-----------|---------|-------|-----|
| spec ref | - | dr | Andy Lu | 2017-10-24 | projection | MM | size | A2 | scale | 5:1 |
| tolerance std | ISO 406 ISO 1101 | eng | Andy Lu | 2017-10-24 | | | ecn no | | | |
| TOLERANCES UNLESS OTHERWISE SPECIFIED | | chr | Fancy Zhong | 2017-10-24 | | | rel level | In Work | | |
| surface | linear | appr | Pei-Ming Zhong | 2017-10-24 | product family | | rel level | | | |
| | 0.X ±0.5 | Amphenol FCI | | eHPCE VERTICAL RECEPTACLE | cat. no. | 10140903 | rel level | | | |
| | 0.XX ±0.25 | | | UNIVERSAL DRAWING, MP+S CONFIGURATION | cat. no. | Product - Customer Drw | rel level | | | |
| | 0.XXX ±0.10 | | | | cat. no. | | rel level | | | |
| | angular | 0° ±2° | | | cat. no. | | rel level | | | |
| | | | | | cat. no. | | rel level | | | |

Amphenol FCI

© 2016 APCI

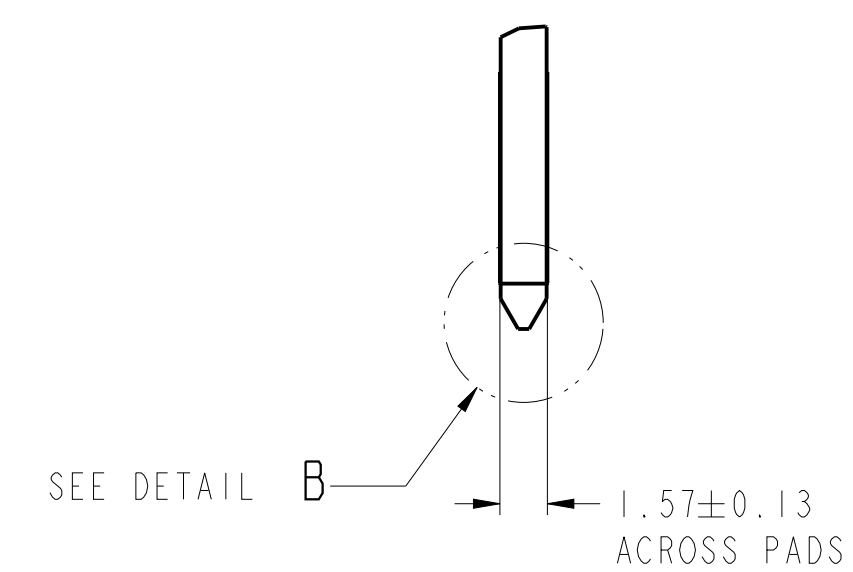
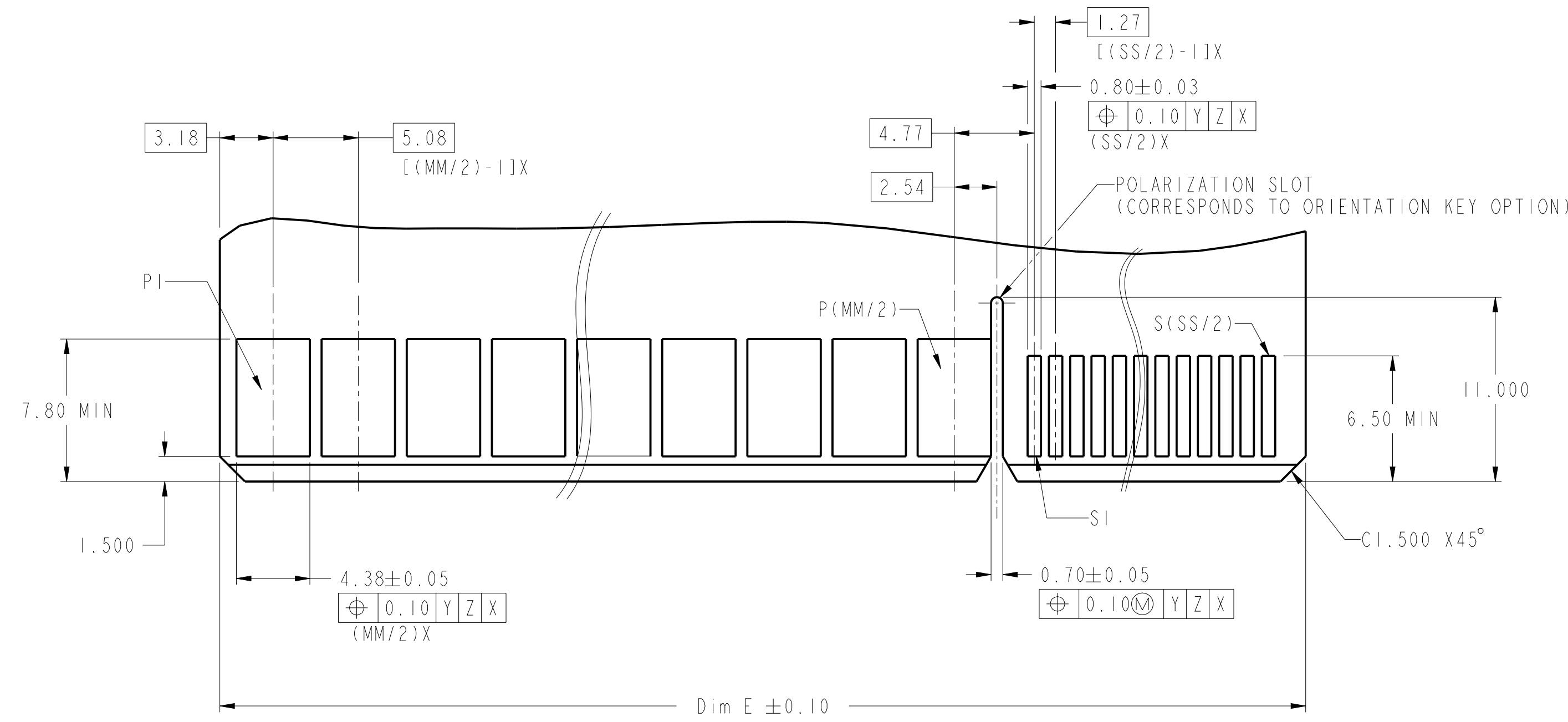

RECOMMENDED MATING BOARD LAYOUT
(DIMENSION TOLERANCE IS ±0.05mm)

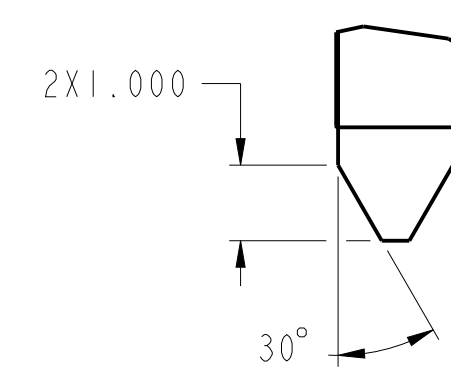

DETAIL B
SCALE 10:1

| | | | | | | | | | | |
|---------------------------------------|---------------------|-------|----------------|---------------------------------------|----------------|---------------------------|----------|------------------------|--------------|-----|
| spec ref | - | dr | Andy Lu | 2017-10-24 | projection | MM | size | A2 | scale | 4:1 |
| tolerance std | ISO 406 ISO 1101 | eng | Andy Lu | 2017-10-24 | | | ecn no | rel level | In Work | rev |
| TOLERANCES UNLESS OTHERWISE SPECIFIED | | chr | Fancy Zhong | 2017-10-24 | | | | | | |
| surface | ISO 1302 | appr | Pei-Ming Zhong | 2017-10-24 | product family | | cat. no. | Product - Customer Drw | sheet 3 of 4 | 7 |
| | linear | 0.X | ±0.5 | Amphenol FCI | | eHPCE VERTICAL RECEPTACLE | | dwg no | 10140903 | |
| | | 0.XX | ±0.25 | UNIVERSAL DRAWING, MP+S CONFIGURATION | | | | | | |
| | | 0.XXX | ±0.10 | | | | | | | |
| | angular | 0° | ±2° | | | | | | | |

Amphenol FCI

© 2016 APCI

10140903 - MM SS * LF

LEAD FREE
BLANK: BLACK
2: BLUE

| | A | B | C | D | E | F |
|----------------------------------|-----------------|----------------|-------------------|-------------------|-------------------|-------------------|
| POLARIZATION KEY OPTION | Y | N | Y | N | Y | N |
| TAIL LENGTH(Dim T) | 3.17 | 3.17 | 3.17 | 3.17 | 2.40 | 2.40 |
| TAIL TYPE/ HOST PCB THICKNESS | PF/ 1.57Min. | PF/ 1.57Min | STB/ 2.36±0.13 | STB/ 2.36±0.13 | STB/ 1.57±0.13 | STB/ 1.57±0.13 |

| DIM | LENGTH FORMULAS |
|-------|----------------------------------|
| DIM A | (MM/2)X5.08 + (SS/2)X1.27 + 9.12 |
| DIM B | DIM "A" - 5.00 |
| DIM C | DIM "A" - 0.94 |
| DIM D | DIM "A" - 4.04 |
| DIM E | DIM "A" - 5.30 |

MIDDLE POWER CONTACTS QTY(36MP Max.) SIGNAL CONTACTS QTY(36S Max.)

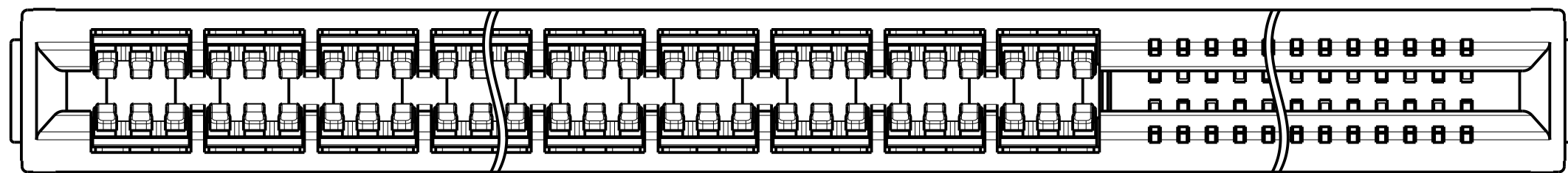

| G | H |
|-------------------|-------------------|
| Y | N |
| 3.75 | 3.75 |
| STB/ 3.00±0.13 | STB/ 3.00±0.13 |

EXAMPLE: THE CONFIGURATION ABOVE IS 10140903-1824A2LF
eHPCE VERTICAL RECEPTACLE PF TYPE WITH 18MP24S AND POLARIZATION KEY;
18MP MEANS 18PCS MIDDLE POWER CONTACTS, 24S MEANS 24PCS SIGNAL CONTACTS.

TABLE 3. PART NUMBER CODE. eHPCE VERTICAL MP+S CONFIG

NOTES:

- 1) PRODUCT MARK:
PART NUMBER AND DATE CODE TO BE MARKED ON THIS SURFACE.
THE MARK CAN BE OMITTED IF THERE IS NOT ENOUGH SPACE ON THIS SURFACE.
- 2) MATERIALS:
-HOUSING : HIGH TEMP THERMOPLASTIC WITH GLASS FIBER, UL94V-0, BLUE
-POWER CONTACT : HIGH CONDUCTIVITY COPPER ALLOY.
-SIGNAL CONTACT : COPPER ALLOY
- 3) PLATING SPECIFICATION:
-POWER CONTACT:
CONTACT AREA: GCS OVER NI+LUBRICANT, LUBRICANT APPLICATION AT THE END OF THE PLATING LINE
SOLDER TAIL AREA: MATTE SN OVER NI
-SIGNAL CONTACT:
CONTACT AREA:GXT OVER NI
SOLDER TAIL AREA: MATTE SN OVER NI
- 4) DENOTES CONNECTOR KEEP OUT ZONE.
- 5) DATUM AND BASIC DIMENSIONS WERE ESTABLISHED BY CUSTOMER.
- 6) ALL HOLE DIAMETERS ARE FINISHED HOLE SIZES.
- 7) THE PRODUCT OF PF TYPE IS NOT INTENDED TO BE EXPOSED TO A MANUFACTURING SOLDER PROCESS.
THE HOUSING OF STB TYPE WILL WITHSTAND EXPOSURE TO 245 °C PEAK TEMPERATURE FOR 10 SECONDS
IN A WAVE SOLDER APPLICATION.
- 8) THIS PRODUCT MEETS EUROPEAN UNION DIRECTIVES AND OTHER COUNTRY REGULATIONS AS DESCRIBED IN GS-47-0004.
- 9) PRODUCT SPECIFICATION : GS-12-1380.
APPLICATION SPECIFICATION : GS-20-0488, APPLICATION TOOLING FOR PF TYPE,SEE DRAWING 10141462.
PRODUCT PACKAGE SPECIFICATION: GS-14-2532.
- 10) MOUNTING HOLES ARE UNPLATED
∅ 2.40+/-0.05 FOR PRESS FIT(PF) TAILS.
∅ 2.18+/-0.03 FOR SOLDER TO BOARD(STB) TAILS.
- 11) MAXIMUM OVERALL LENGTH IS 100mm.

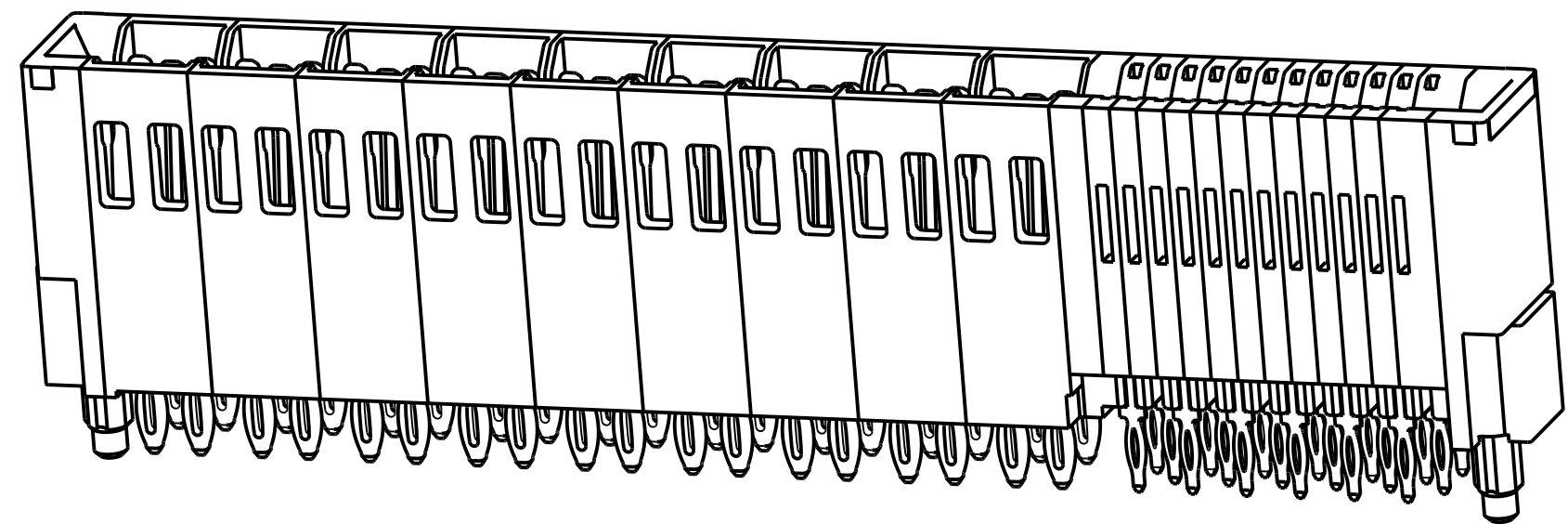

EXAMPLE: 10140903-1824A2LF

| | | | | | | | | | | |
|---------------------------------------|---|------|----------------|------------|--|----|----------|------------------------|--------------|-----|
| spec ref | - | dr | Andy Lu | 2017-10-24 | projection | MM | size | A2 | scale | 2:1 |
| tolerance std | ISO 406 ISO 1101 | eng | Andy Lu | 2017-10-24 | | | ecn no | rel level | In Work | rev |
| TOLERANCES UNLESS OTHERWISE SPECIFIED | | chr | Fancy Zhong | 2017-10-24 | | | | | | |
| surface | linear 0.X ±0.5 0.XX ±0.25 0.XXX ±0.10 | appr | Pei-Ming Zhong | 2017-10-24 | Amphenol FCI eHPCE VERTICAL RECEPTACLE | | cat. no. | Product - Customer Drw | sheet 4 of 4 | |
| ISO 1302 | angular 0° ±2° | | | | UNIVERSAL DRAWING,MP+S CONFIGURATION | | | | | |

Amphenol FCI

© 2016 AFCI