

# PRODUCT DATA DRAWING

REVISION HISTORY			
REV	DESCRIPTION	DATE	APPROVED
E	DCN 40879	10/14	STW
F	REV. DCN 41443	06/26/15	JMC

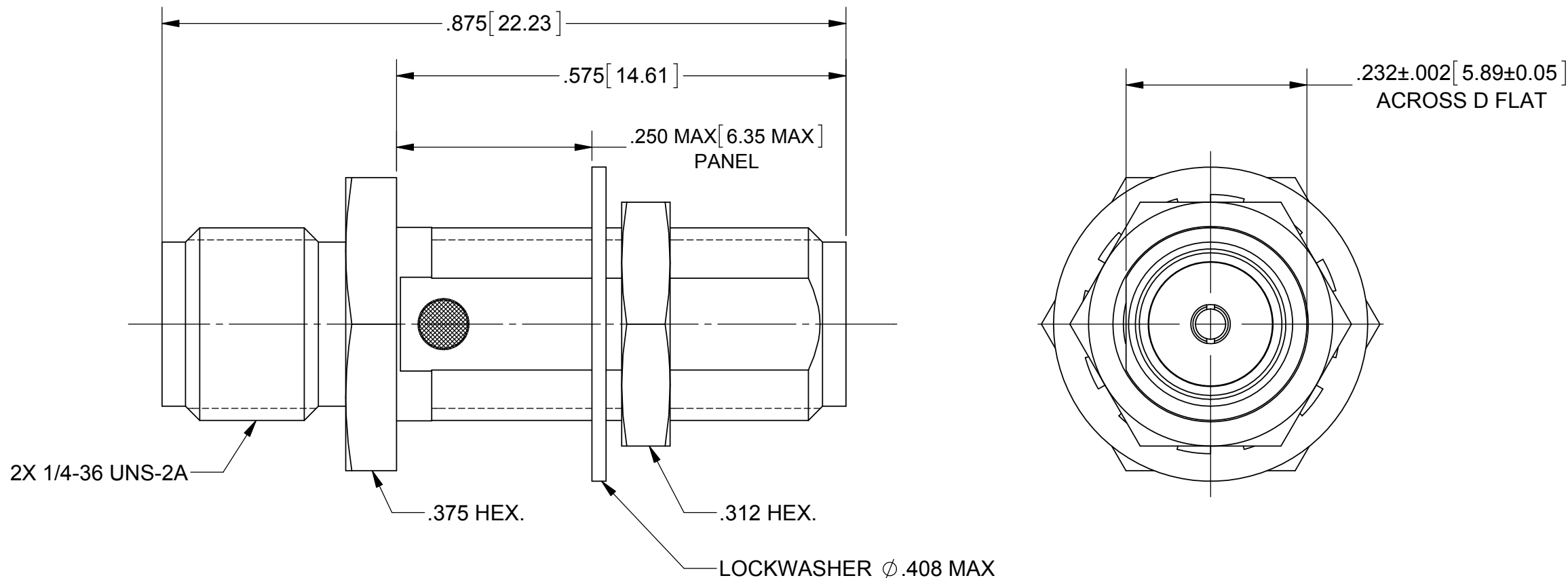
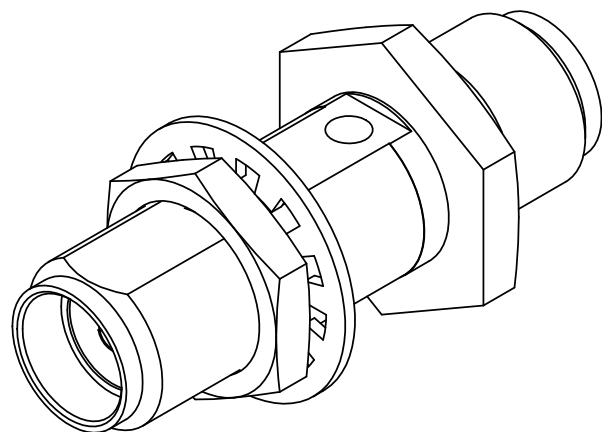

**MATERIAL:**

BODY & HEX NUT: STAINLESS STEEL PER AMS-5640, ALLOY UNS S30300, TYPE 1

LOCKWASHER: 300 SERIES STAINLESS STEEL

CONTACT: BERYLLIUM COPPER PER ASTM B196, ALLOY No. UNS C17300, TD04

INSULATOR: PTFE PER ASTM D1710, TYPE I, GRADE 1, CLASS B

**FINISH:**

BODY, LOCKWASHER & HEX NUT: GOLD PER ASTM B 488, TYPE I, CODE C, CLASS 0.50, OVER NICKEL PER AMS-QQ-N-290, CLASS 1, .00005" MIN.

CONTACT: GOLD PER ASTM B488, TYPE II, CODE C, CLASS 0.76, OVER NICKEL PER AMS-QQ-N-290, CLASS 1, .00005" MIN.

**PERFORMANCE:**

IMPEDANCE: 50 OHMS  
 FREQ. RANGE: DC TO 18.0 GHz  
 VSWR: 1.05 + .010(F IN GHz) DC TO 18.0 GHz

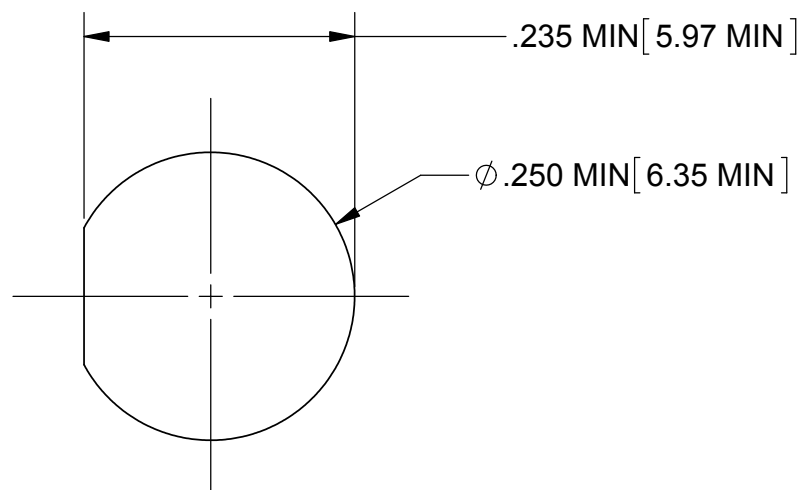

**RECOMMENDED MOUNTING HOLE**

MATERIAL: SEE NOTES	DIMENSIONS ARE IN INCHES TOLERANCES: FRACTIONAL: $\pm 1/64$ ANGULAR: X° $\pm 1'0''$ X'X' $\pm 15'$	UNLESS OTHERWISE SPECIFIED	<b>SV Microwave, Inc.</b> 2400 Centrepark West Drive, Suite 100 West Palm Beach, FL 33409 TITLE: SMA JACK TO JACK JAM NUT MOUNT
FINISH: SEE NOTES	DECIMAL: X $\pm .030$ .XX $\pm .010$ .XXX $\pm .005$	1) ALL DIMENSIONS ARE IN INCHES (MILLIMETERS) 2) ALL DIMENSIONS ARE AFTER PLATING. 3) BREAK CORNERS & EDGES .005 R. MAX. 4) CHAM. 1ST & LAST THREADS. 5) SURFACE ROUGHNESS 63-MIL-STD-10. 6) DIA. 'S ON COMMON CENTERS TO BE CONCENTRIC WITHIN .005 T.I.R. 7) REMOVE ALL BURRS	
SURFACE AREA: N/A	INTERPRET DIMENSIONS AND TOLERANCES PER ASME Y14.5M - 1994	THIRD ANGLE PROJECTION	DWG. NO. 2990-6005 SCALE: 4:1
PROPRIETARY THE INFORMATION CONTAINED IN THIS DRAWING IS THE SOLE PROPERTY OF SV MICROWAVE, INC. ANY REPRODUCTION IN PART OR AS A WHOLE WITHOUT THE WRITTEN PERMISSION OF SV MICROWAVE, INC IS PROHIBITED.	DRAWN: MGT 08/26/04 CHECKED: MGT 08/26/04 APPROVED: BRT 08/26/04	SIZE B CAGE CODE 95077	SHEET 1 OF 1