

THIS DRAWING IS UNPUBLISHED.

RELEASED FOR PUBLICATION

20

LOC -

DIST -

REVISIONS

© COPYRIGHT 20 BY - ALL RIGHTS RESERVED.

P	LTR	DESCRIPTION	DATE	DWN	APVD
	C	REV PER ECO 13-006729	4-19-13	CT	DM

SCALE 3:4

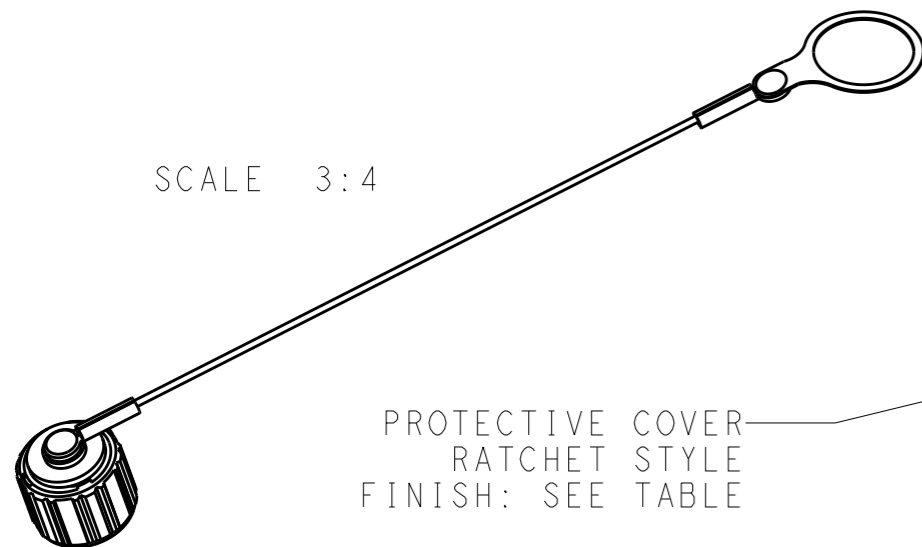

PROTECTIVE COVER
RATCHET STYLE
FINISH: SEE TABLE

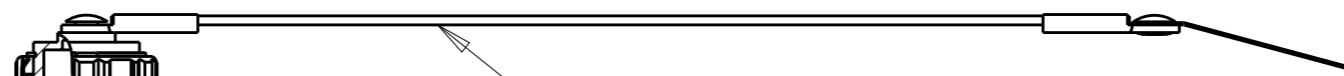

LANYARD:
MATERIAL: STAINLESS STEEL WIRE

2221478-1 AND 2221478-2

(Ø .840)

RING
MATERIAL: SERIES 300 STAIN
STEEL
FINISH: PASSIVATED

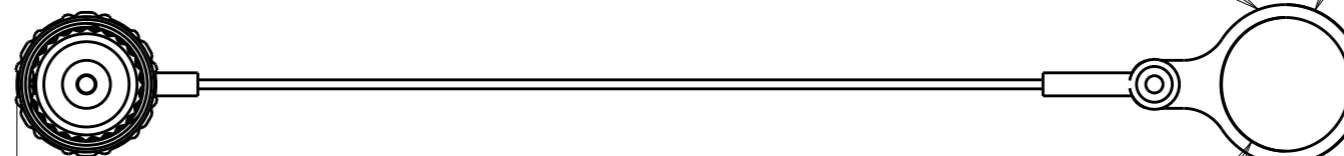

(Ø .695)

(7.000)

RIVET
MATERIAL: STEEL
FINISH: BLACK ZINC NICKEL



2221478-3 AND 2221478-4

(6.049)

(.047)

(Ø .142)

SCALE 3:4

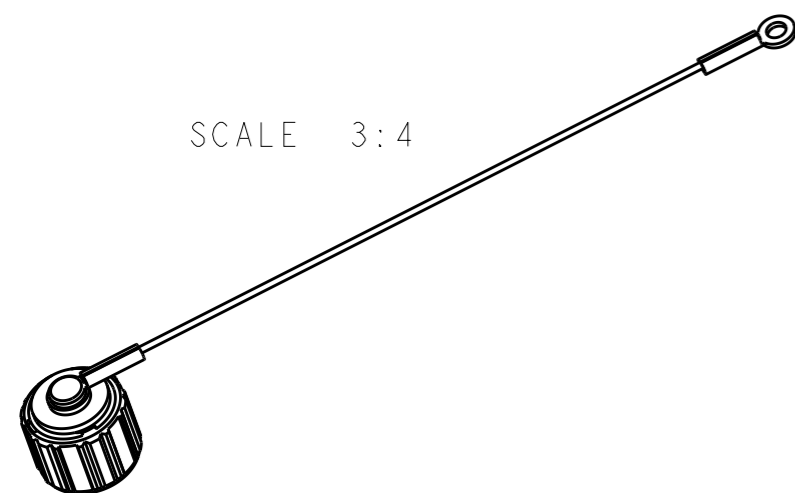

PROTECTIVE COVER
RATCHET STYLE
FINISH: SEE TABLE

(Ø .260)

BLACK ZINC NICKEL	2221478-4
NICKEL PLATE	2221478-3
BLACK ZINC NICKEL	2221478-2
NICKEL PLATE	2221478-1
FINISH	PART NUMBER

THIS DRAWING IS A CONTROLLED DOCUMENT.

DWN 06DEC2011
MCKIBBEN, JOHN
CHK 06DEC2011
DOWHOWER, KENNETH
APVD 06DEC2011

STE TE Connectivity

DIMENSIONS:
INCHES

TOLERANCES UNLESS
OTHERWISE SPECIFIED:

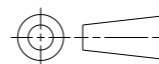

0 PLC ±.
1 PLC ±.1
2 PLC ±.02
3 PLC ±.005
4 PLC ±.0005
ANGLES ±.

MATERIAL SEE TABLE

FINISH -

PRODUCT SPEC -

APPLICATION SPEC -

WEIGHT -

NAME
PROTECTIVE CAP ASSEMBLY
RATCHET STYLE

SIZE	CAGE CODE	DRAWING NO	RESTRICTED TO
A3	00779	C-2221478	-

Customer Drawing

SCALE 1:1

SHEET 1 OF 1

REV C