

ISS.	DATE	E.C.N.	DESCRIPTION
1	14-May-09		FIRST ISSUE

© 2008 CARCLO  
ALL DIMENSIONS IN mm

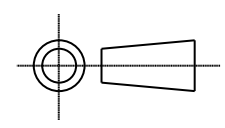

CARCLO TECHNICAL PLASTICS (SLOUGH)  
111 BUCKINGHAM AVE, SLOUGH  
SL1 4PF, ENGLAND  
TEL: +44 1753 575011 FAX: +44 1753 811359  
e-mail: design@carclo-optics.com

CUSTOMER DRAWING

GENERAL TOLERANCES (UNLESS STATED)

LINEAR	ANGULAR
X +/- 0.25	X +/- 1°
X.X +/- 0.1	X.X +/- 0.5°
X.XX +/- 0.05	X.XX +/- 0.1°

CUSTOMER

CARCLO

TITLE

10MM QUAD OPTIC  
CIRCULAR FLANGE

DRAWN DATE

MKI 14-May-09

CHK'D DATE

APP'D DATE

SCALE CARCLO PART No.

2:1 10622

SIZE CARCLO DRG. No. SHEET

A4 60572 1 OF 2

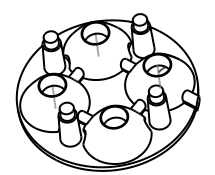
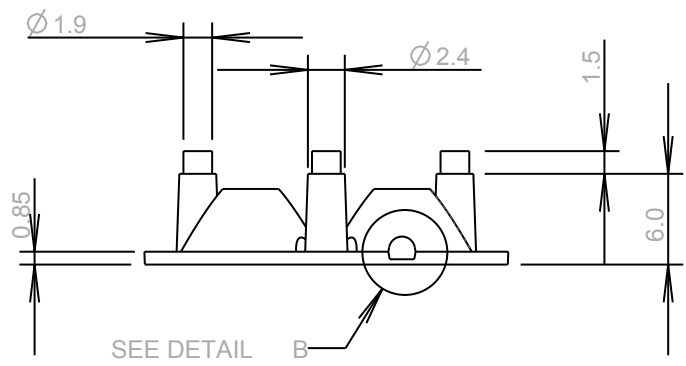
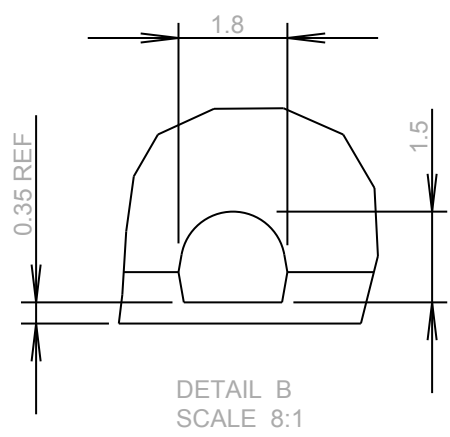
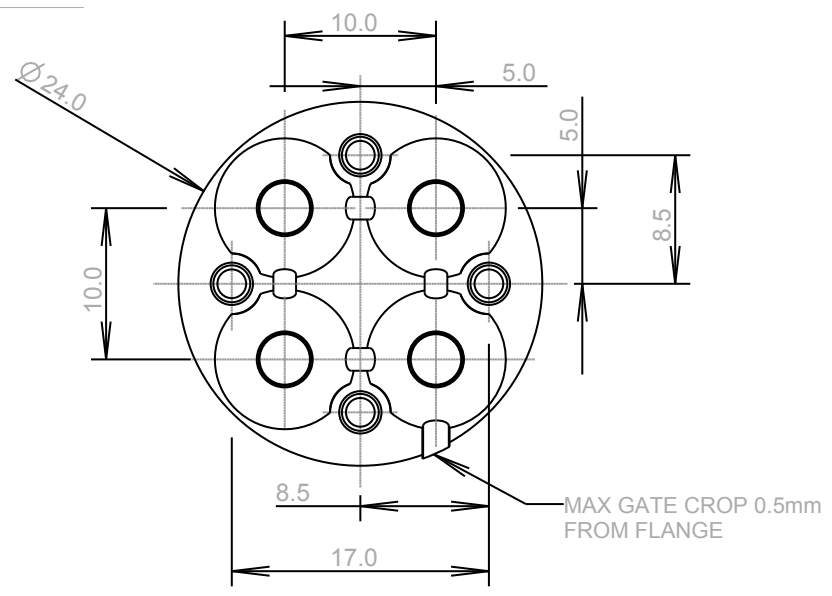

3D GENERAL VIEW  
SCALE 1:1

MATERIAL - UV STABILISED CLEAR POLYCARBONATE

ISS.	DATE	E.C.N.	DESCRIPTION
1	14-May-09		FIRST ISSUE

© 2008 CARCLO  
ALL DIMENSIONS IN mm

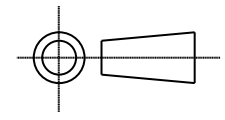

CARCLO TECHNICAL PLASTICS (SLOUGH)  
111 BUCKINGHAM AVE, SLOUGH  
SL1 4PF, ENGLAND  
TEL: +44 1753 575011 FAX: +44 1753 811359  
e-mail: design@carclo-optics.com

PCB HOLE & GLUE PAD LOCATION

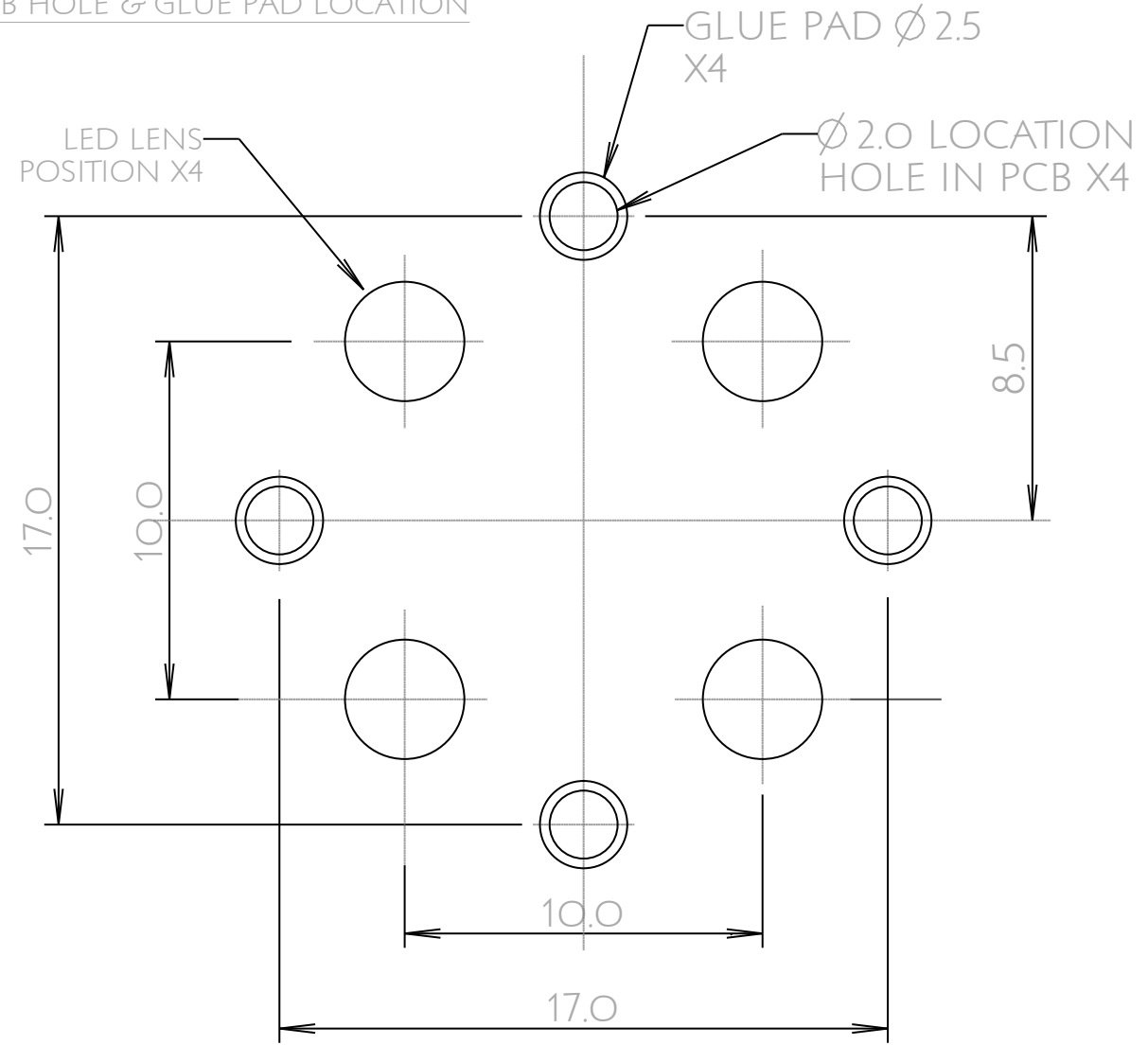

GENERAL TOLERANCES (UNLESS STATED)

LINEAR	ANGULAR
X +/- 0.25	X +/- 1°
X.X +/- 0.1	X.X +/- 0.5°
X.XX +/- 0.05	X.XX +/- 0.1°

CUSTOMER  
CARCLO

TITLE  
10MM QUAD OPTIC SPOT  
CIRCULAR FLANGE

DRAWN MKI DATE 14-May-09

CHK'D DATE

APP'D DATE

SCALE 2:1 CARCLO PART No. 10622

SIZE A4 CARCLO DRG. No. 60572 SHEET 2 OF 2