

THIS COPY IS PROVIDED ON A RESTRICTED BASIS AND IS NOT TO BE USED IN ANY WAY DETRIMENTAL TO THE INTERESTS OF PANDUIT CORP.

PANDUIT P/N	WEIGHT
SRBBRM-KIT	.74 LB/EACH PC (335.7 g/EACH PC)

NOTES:

- SEE CURRENT CATALOG FOR ADDITIONAL PART NUMBER SUFFIXES TO INDICATE COLOR AND OR PACKAGE QUANTITY.
- SEE CATALOG FOR COMPLETE LIST OF PARTS APPLICABLE FOR USE WITH THIS PART.
- DIMENSIONS IN PARENTHESES ARE IN METRIC.
- PART INCLUDES:
  - 1- STRAIN RELIEF BAR
  - 6- TAK-TY
  - 1- #12-24 SCREW KIT
  - 1- M6 SCREW KIT
  - 2- RATCHET FASTENER
  - 2- LATCH BRACKET
  - 2- TAB BRACKET (ASSEMBLED TO THE STRAIN RELIEF BAR)

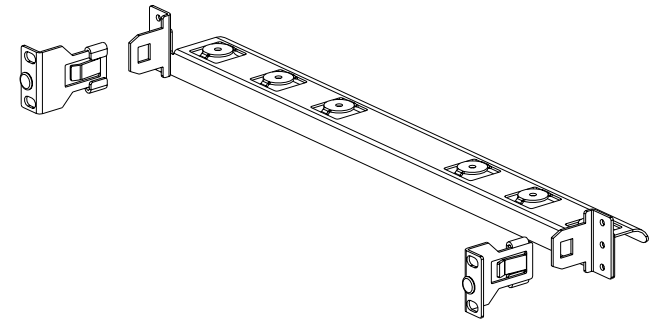
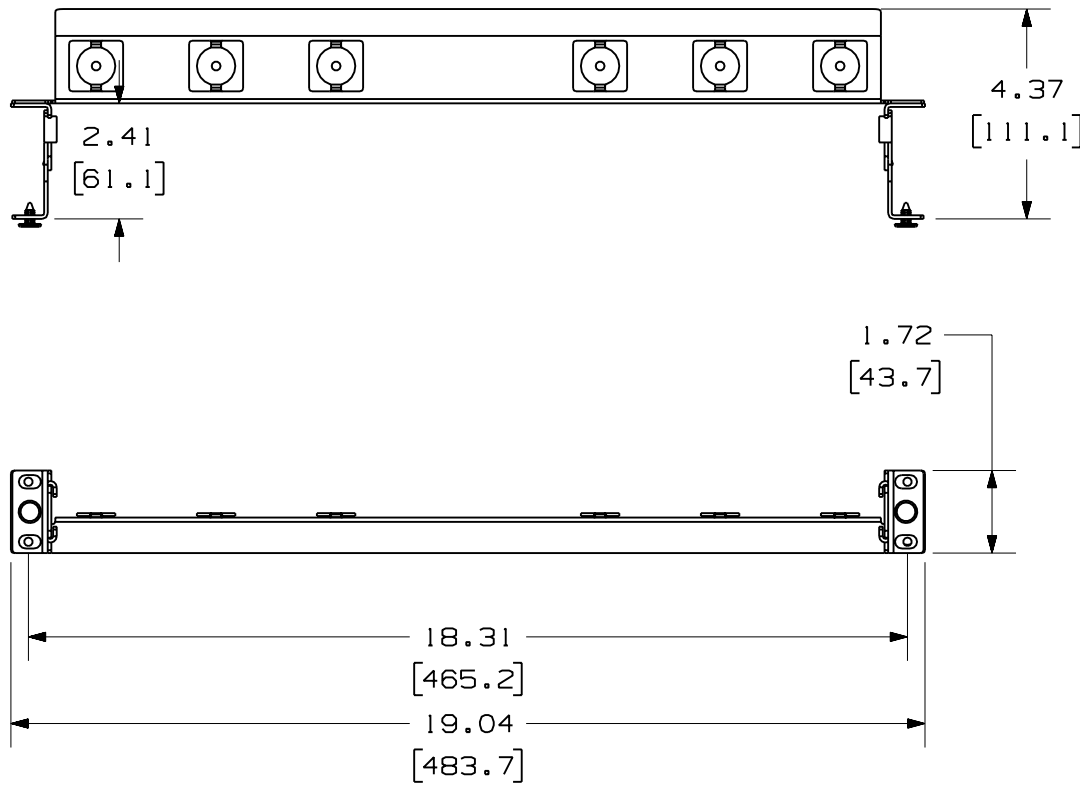

MODEL FILENAME	M02644AA_SRBBRM-KIT_00.PRT	SIZE	A
DRAWING FILENAME	M02644AA_DC_00A.PRT		

STRAIN RELIEF BAR KIT WITH SRBM19BLY AND QUICK RELEASE BRACKETS  
CUSTOMER DRAWING

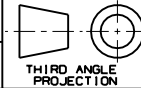
 <b>PANDUIT</b> ™ CORP. TINLEY PARK, ILL 60477	I.T. NUMBER	N/A
	PRODUCT SPEC	N/A
 THIRD ANGLE PROJECTION	WORK INSTRUCTION	N/A
	SCALE	NONE
DRAWN BY JsP	MATERIAL:	PART NO. SRBBRM-KIT
DATE 9-19-06	STRAIN RELIEF BAR-C.R.S.	DRAWING NO. 02644-01
CHK'D	QUICK RELEASE BRACKETS-C.R.S.	

REV	DATE	BY	CHK	DESCRIPTION	ECN	R	CUST	SUP	OTH
R	9-19-06	JsP		RELEASED TO PRODUCTION	02644-01				