

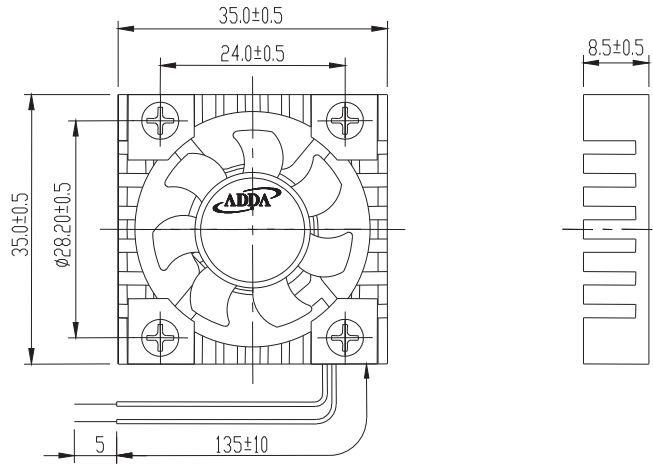

AP3508 SERIES

External Dimensions

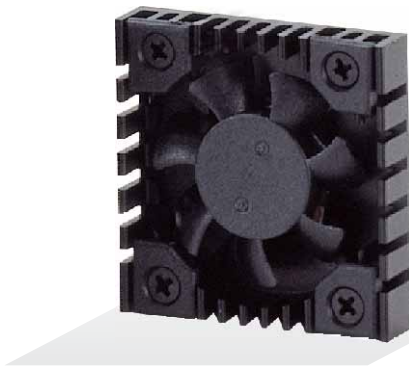

Frame: Aluminum alloy
 Impeller: Plastic(UL:94V-0)
 Lead wire: UL1571AWG28

Specifications(Nominal)

*Noise is measured at the distance of one (1) meter from the axis of intake.

Bearing type: ○=Ball ※=Sleeve ●=Hypro bearing

Frame size (mm)	Model No.	Bearing System Type	Rated Voltage (VDC)	Current (A)	Power (W)	Rated Speed (rpm)	Maximum AirFlow (CMM, CFM)		Maximum Pressure (InAq, mmAq)		*Noise Level (dB/A)	Weight (g)
35x35x08	AP3505LX-J70(TX)	●	5	0.07	0.35	7500	0.071	2.40	0.082	2.05	20.0	12.0
	AP3505MX-J70(TX)	●	5	0.11	0.55	9000	0.093	3.30	0.138	3.45	27.9	
	AP3505HX-J70(TX)	●	5	0.13	0.65	10500	0.116	4.10	0.151	3.78	32.0	
	AP3512MX-J70(TX)	●	12	0.06	0.72	9000	0.093	3.30	0.138	3.45	27.9	
	AP3512HX-J70(TX)	●	12	0.09	1.08	10500	0.116	4.10	0.151	3.78	32.0	

Specifications subject to change without notice.

The specification for bearing type is for reference only, for more bearing types information, please contact with your ADDA sales representative, thanks!!
 (網頁上呈現產品軸承資訊均以參考為主，若需其他產品資訊請聯絡您在ADDA的業務代表，謝謝!!)

*Motor protective circuit and third lead wire functions

0	1	2	3	4	6	7	8	9	A	B
✓										

*Safety approvals

✓	✓		✓	✓