

# RR-HR

D-Sub connectors - Stamped and Formed Contacts

## REAR RELEASE CRIMP CONNECTORS



### Specifications

- Connectors according to MIL C24308

| Materials and Platings     |  |                   |
|----------------------------|--|-------------------|
| <b>Shells</b>              | Tinned steel with or without dimples on plug connector                               |                   |
| <b>Insulator Boardlock</b> | Black glass-filled thermoplastic, UL 94V-0   |                   |
|                            | Brass, 3µm to 5µm (118µ" to 197µ")<br>tin over nickel 2µm to 3µm<br>(78µ" to 118µ")  |                   |
| <b>Screwlock</b>           | Brass, 6µm to 10µm (236µ" to 394µ")<br>tin over nickel 2µm to 3µm<br>(78µ" to 118µ") |                   |
| Contacts-Brass             | Under plating  | Crimp side        |
| 0.2µm (8µ") gold           | 2µm (78µ") nickel  | gold flash or tin |
| 0.5µm (20µ") gold          | 2µm (78µ") nickel  | gold flash or tin |
| 0.76µm (30µ") gold         | 2µm (78µ") nickel  | gold flash or tin |

| Electrical Data              |  |
|------------------------------|--|
| <b>Current rating</b>        | 5A   |
| <b>Voltage rating</b>        | 500V AC/rms 50Hz   |
| <b>Withstanding voltage</b>  | RR: 1000V AC/rms 50Hz for 1 minute<br>HR: 1000V AC/rms 60Hz for 1 minute |
| <b>Insulation resistance</b> | RR: 5000MΩ<br>HR: 1000MΩ   |
| <b>Contact resistance</b>    | 10mΩ max   |
| <b>Wire size</b>             | 20-28 AWG max insulation<br>Ø1.27mm (.05")                               |

| Climatic Data                |                 |
|------------------------------|-----------------|
| <b>Operating temperature</b> | -55°C to +125°C |

| Mechanical Data           |             |               |               |              |             |
|---------------------------|-------------|---------------|---------------|--------------|-------------|
| Mating and unmating force |             |               |               |              |             |
| Unit: kg ( lb)            |             |               |               |              |             |
| No. of Cts                |             | Mate (max)    |               | Unmate (min) |             |
| RR                        | HR          | RR            | HR            | RR           | HR          |
| 9 (size E)                | 15 (size E) | 3.05 (6.74)   | 3.81 (8.42)   | 0.36 (0.79)  | 0.52 (1.14) |
| 15 (size A)               | 26 (size A) | 5.09 (11.24)  | 5.95 (13.16)  | 0.46 (1.01)  | 1.05 (2.32) |
| 25 (size B)               | 44 (size B) | 8.44 (18.66)  | 9.26 (20.46)  | 0.81 (1.8)   | 1.37 (3.02) |
| 37 (size C)               | 62 (size C) | 12.51 (27.65) | 13.48 (29.78) | 1.1 (2.47)   | 1.76 (3.88) |
| 50 (size D)               | 78 (size D) | 14.65 (32.38) | 15.82 (34.96) | 1.6 (3.56)   | 2.02 (4.46) |

Designed for high volume production, Amphenol's rear release crimp connector and contacts provide significant cost saving.

- EMI / RFI shell configuration.
- Removable, reusable contacts.
- Automatic and manual tooling available.

*Simplify your cable assemblies*

- Commercial
- Industrial
- Telecom
- Any industry standard I / O connections



**Amphenol**

CHARACTERISTICS

DESCRIPTION

APPLICATIONS

RR-HR / E11

Standard density RR



| Nb OF CONTACTS | DIMENSIONS mm (inch) |              |              |              |              |              |      |
|----------------|----------------------|--------------|--------------|--------------|--------------|--------------|------|
|                | A                    | B            | C            | D            | E            | F            | X    |
| 9              | 30.84 (1.21)         | 24.99 (.98)  | 16.92 (.67)  | 16.24 (.64)  | 11.09 (.44)  | 19.28 (.76)  | 2.77 |
| 15             | 39.24 (1.54)         | 33.32 (1.31) | 24.7 (.972)  | 24.56 (.97)  | 19.39 (.76)  | 27.51 (1.08) | 2.77 |
| 25             | 53.04 (2.09)         | 47.04 (1.85) | 38.96 (1.53) | 38.38 (1.51) | 33.24 (1.31) | 41.30 (1.63) | 2.77 |
| 37             | 69.32 (2.73)         | 63.50 (2.50) | 55.42 (2.18) | 54.76 (2.16) | 49.86 (1.96) | 57.71 (2.27) | 2.77 |
| 50             | 67 (2.64)            | 61.11 (2.41) | 52.86 (2.08) | 52.34 (2.06) | 44.32 (1.75) | 55.3 (2.18)  | 2.77 |



# High density HR



| Nb OF CONTACTS | DIMENSIONS mm (inch) |              |              |              |              |
|----------------|----------------------|--------------|--------------|--------------|--------------|
|                | A                    | B            | C            | D            | E            |
| 15             | 30.84 (1.21)         | 24.99 (.98)  | 16.92 (.67)  | 16.24 (.64)  | 19.28 (.76)  |
| 26             | 39.24 (1.54)         | 33.32 (1.31) | 24.7 (.972)  | 24.56 (.97)  | 27.51 (1.08) |
| 44             | 53.04 (2.09)         | 47.04 (1.85) | 38.96 (1.53) | 38.38 (1.51) | 41.30 (1.63) |
| 62             | 69.32 (2.73)         | 63.50 (2.50) | 55.42 (2.18) | 54.76 (2.16) | 57.71 (2.27) |
| 78             | 67 (2.64)            | 61.11 (2.41) | 52.86 (2.08) | 52.34 (2.06) | 55.3 (2.18)  |



Panel mounting option

Standard density:



Standard rivet  $\varnothing$  3.05mm  
no digit



Fixed front female screwlock  
VF / VFM

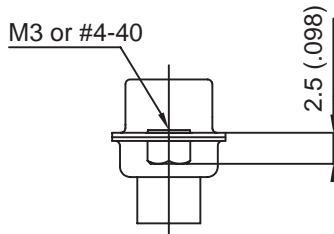

Threaded rear insert  
H / G

High density:

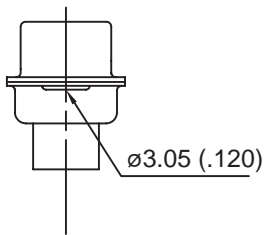

Standard rivet  $\varnothing$ 3.05mm  
no digit

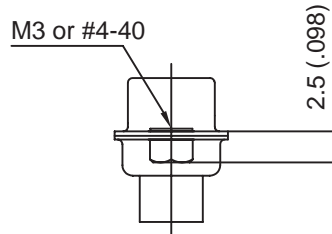

Threaded rear insert  
H / G

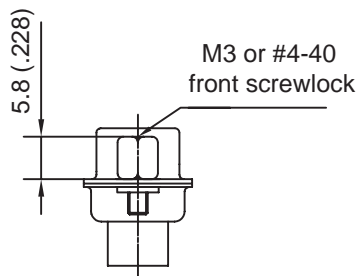

Fixed front female screwlock  
VF / VFM

## Contacts

### Standard density:

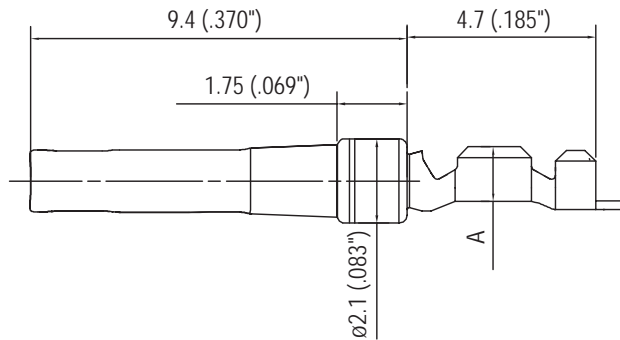
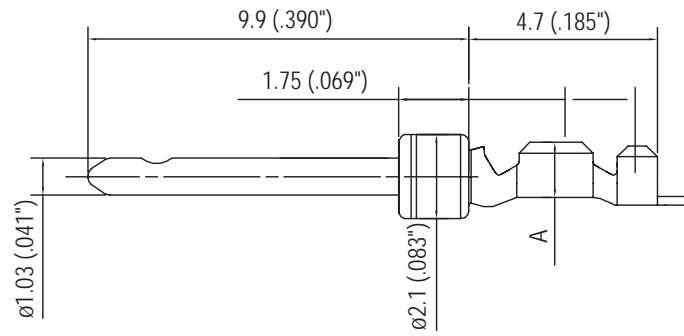
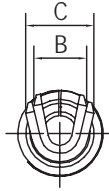

| AWG   | A           | B           | C           |
|-------|-------------|-------------|-------------|
| 20-24 | 1.8 (.071") | 1.9 (.075") | 2.5 (.098") |
| 24-28 | 1.4 (.055") | 1.5 (.059") | 1.7 (.066") |

### High density:

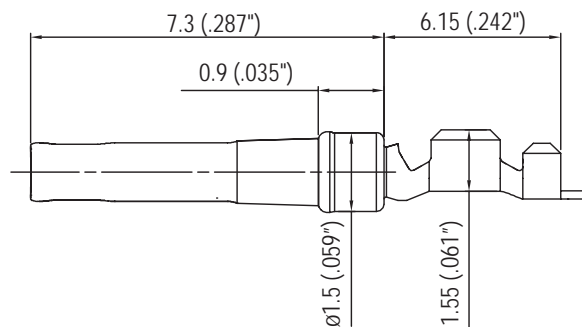
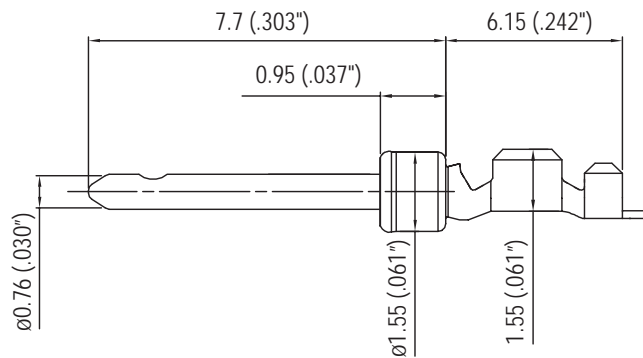
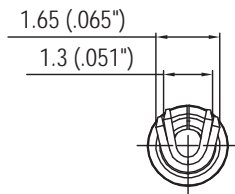

## How to order RR (standard density)

### Housings

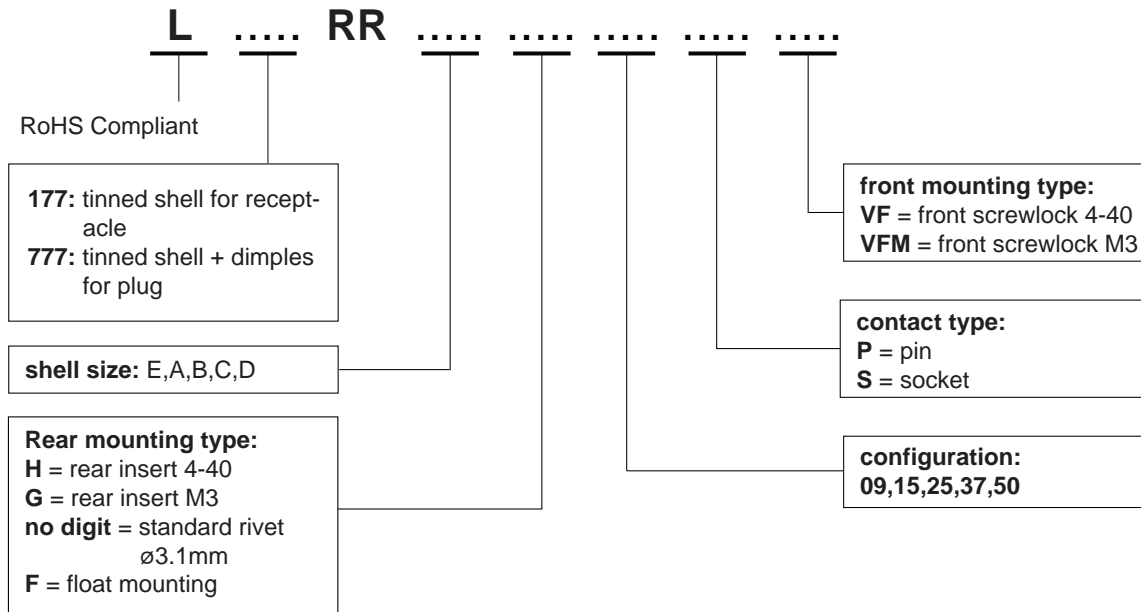

### Contacts

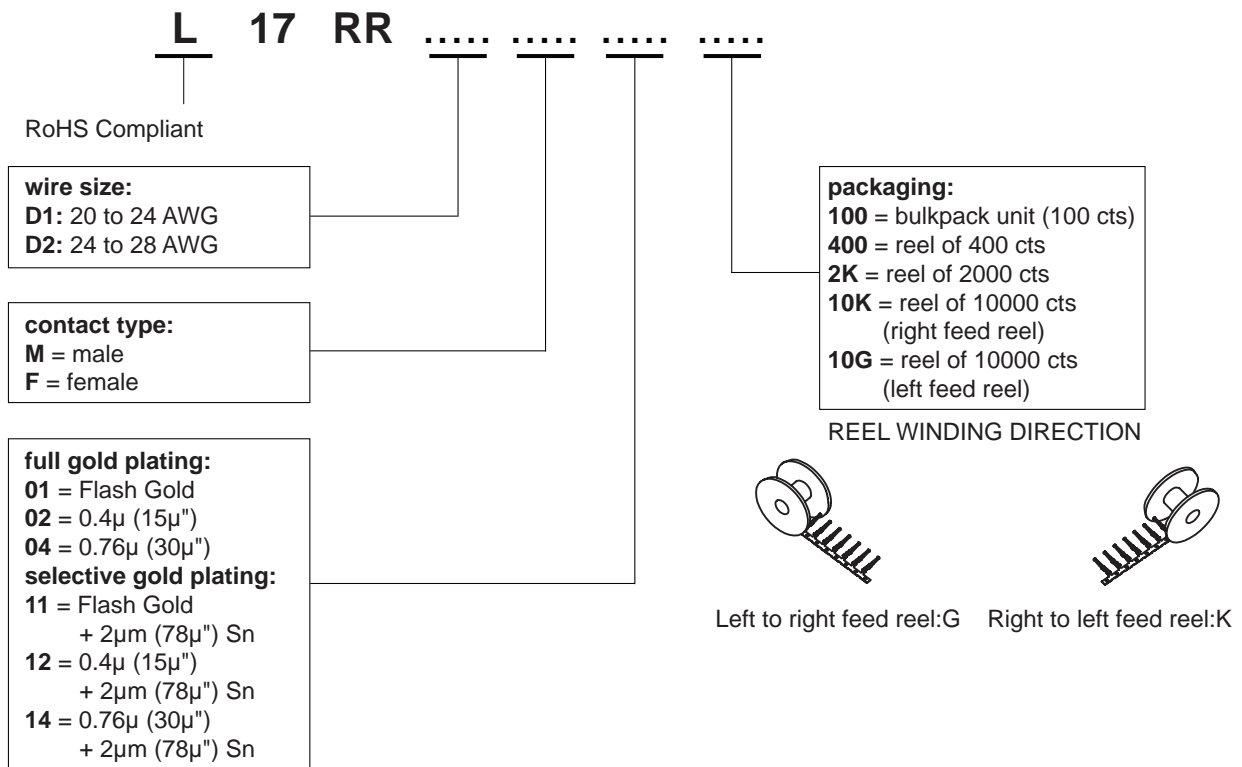

*For special request, please consult factory*

# How to order HR (high density)

## Housings



## Contacts

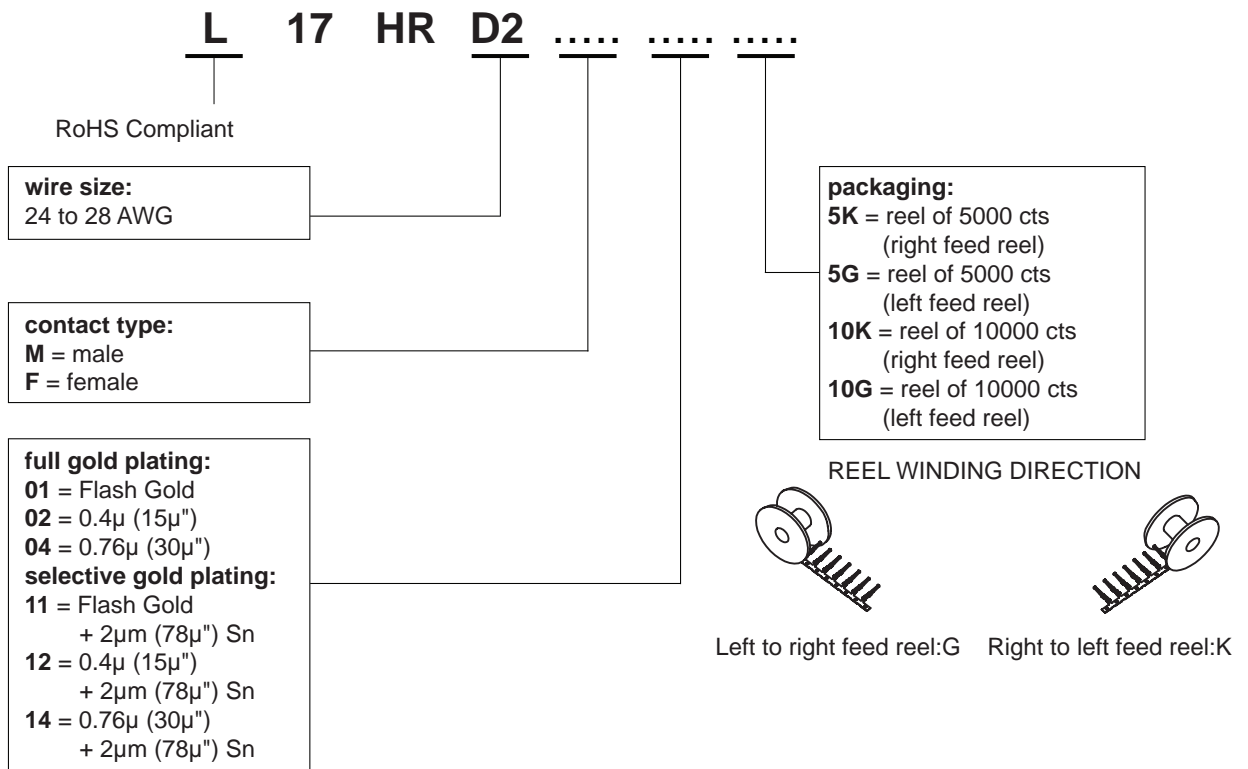

*For special request, please consult factory*

## Tooling for crimp contacts

### For standard density crimp contacts: 17RR series

- |   |             |
|---|-------------|
| • contact insertion and removal tool                          | 17D 438 SP  |
| • hand crimp tool for single contacts AWG 20 to 28            | 17D 440 SP  |
| • hand crimp tool for reels of 400 contacts                   | FA 0000 762 |
| crimp dies: AWG 20 to 24                                      | FA 0000 104 |
| crimp dies: AWG 24 to 28                                      | FA 0000 102 |
| • stripping box   | FE 0400     |
| • automatic crimp machine for reels of 2000 to 10000 contacts | 970 MC      |
| crimp dies: AWG 20 to 24                                      | 968 MC      |
| crimp dies: AWG 24 to 28                                      | 972 MC      |

### For high density crimp contacts: 17HR series

- |   |        |
|---|--------|
| • automatic crimp machine for reels of 2000 to 10000 contacts | 970 MC |
| crimp dies: AWG 24 to 28                                      | 973 MC |

Do not hesitate to contact us for further information

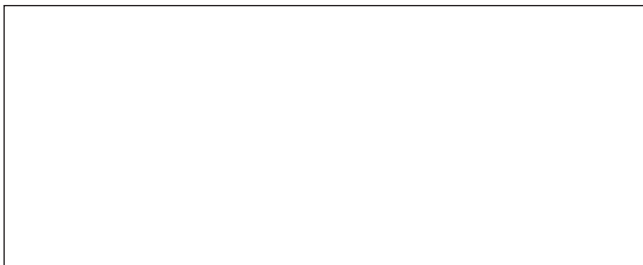

# Amphenol

## Amphenol IT & Communication Products

Block A3/A4, The 4th Industrial District of  
Industrial Headquarters, Dong Keng Road  
Gong Ming Town, Shen Zhen China  
Fax: +86(0)755 2754 9955

### Technical Support

Tel: +86(0)755 2717 7945  
Info-dsub@amphenol.com.cn  
<http://www.dsubconnector.com>