

PART NAME: KNOB SCALE: 1:1 DATE: 6/27/91 DR. BY HD

THIS DRAWING IS THE PROPERTY OF DAVIES MOLDING COMPANY, IS SUBMITTED SOLELY AS A DESIGN OR ENGINEERING PROJECT. WE ACCEPT NO RESPONSIBILITY WHATSOEVER FOR THE PRACTICAL APPLICATION OF THE PIECES MADE TO THIS DESIGN.



DESIGNERS & MANUFACTURERS OF KNOBS, HANDLES, CASES & CUSTOM PLASTIC COMPONENTS

P/N	4232-B
M NO.	73
CAVITY	4232
CAVITY PLUG	4232-3
CORE	4230
CORE BUSHING	4230
SLEEVE BUSHING	4230
SLEEVE	4230
PIN BUSHING	4230-Y
OUTER PIN	4230-1
INNER PIN	4232-B
INSERT	11673

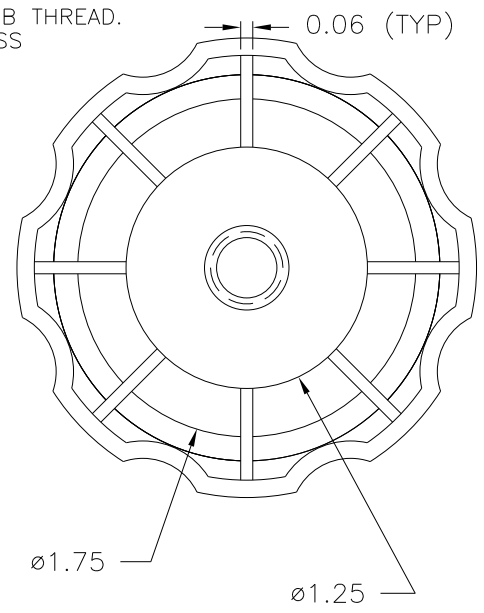
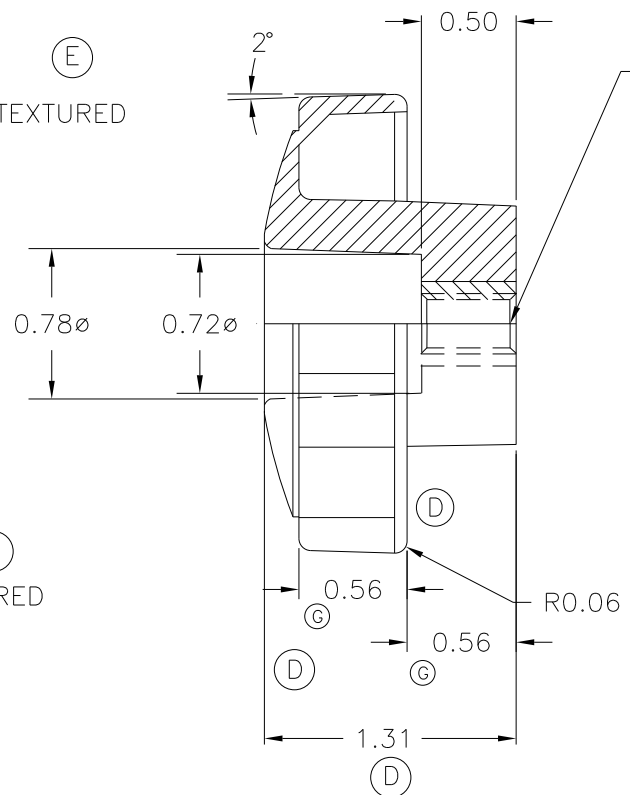
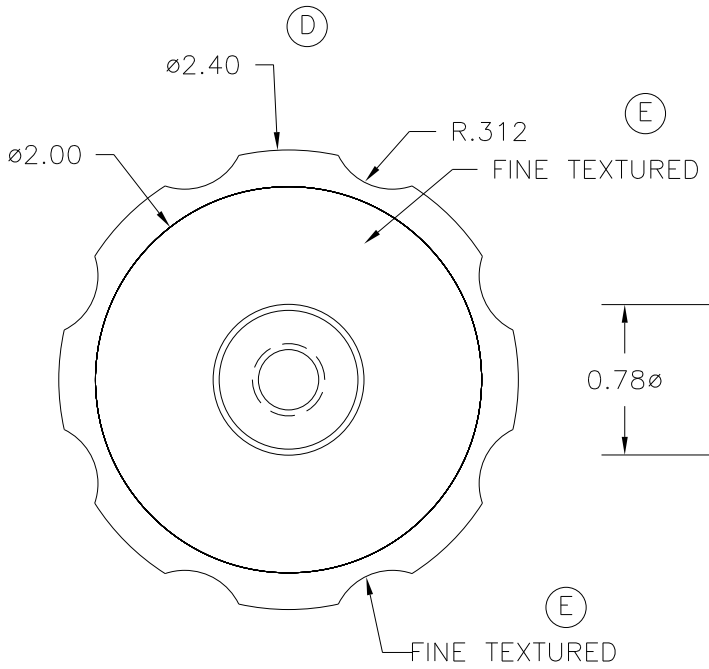

(F)
(A)
(B)

©
MATERIAL : 20% TALC FILLED PP
COLOR : BLACK

G	UPDATED DIMENSIONS TO MATCH TOOLING	JAM	11/26/01
F	UPDATED TOOLBOX	JAM	10/15/01
E	TEXTURE WERE MATTE FINISH	ST	12/5/00
D	.57 WAS .63 1.31 WAS 1.28	MP	4/16/98
D	2.40 WAS 2.38 .56 WAS .50	MP	4/16/98
C	20% TALC FILLED PP WAS POLYPROPYLENE	MP	4/16/98
-	UPDATED DWG.	HD	5/2/96
B	PINS REVISED	HD	6/29/95
A	CAV.PLUG REVISED	HD	5/7/93
-	CAD/REDRAWN	HD	6/29/95

TOLERANCES: UNLESS OTHERWISE SPECIFIED	DO NOT SCALE DRAWING
DECIMALS: X.XXX ± .005 X.XX ± .015	MM: X.XX ± 0.15MM X.X ± 0.4MM
FRACTIONS ± 1/64	ANG. ± 1°

CHANGES