

## Features/Benefits

- **Bifurcated contact for increased electrical reliability**
- **Process sealed for surface mount soldering and washable processing**
- **RoHS compliant**

## Typical Applications

- **Hand-held electronic devices**
- **Portable computer and electronic devices**
- **Instrumentation and controls**
- **Inverters**



## Specifications

CONTACT RATING: 25 mA @ 24 V DC (switching) or  
100 mA @ 50 V DC (steady state).

MECHANICAL AND ELECTRICAL LIFE: 200 cycles at rated loads.

CONTACT RESISTANCE: 100 mΩ max. initial. @ 2 V DC /10 mA

INSULATION RESISTANCE: 100 MΩ @ 100 V DC min.

DIELECTRIC STRENGTH: 300 V AC /minute

STORAGE TEMPERATURE: -40°C to 85°C.

OPERATING TEMPERATURE: -30°C to 85°C.

OPERATING FORCE: 4.9 N max.

SOLDERABILITY: Per MIL-STD-202F method 208D, or  
EIA RS-186E method 9 (1 hour steam aging).

PACKAGING: 1,000 pieces tape & reel

## Materials

CASE AND COVER: PPS, color black (UL94V-0).

ACTUATOR: LCP (UL94-0)

CONTACTS: Copper alloy with gold plate over nickel plate

TERMINALS (INSERT MOLDED):

Copper alloy gold flash over nickel plate

TAPE SEAL: Polyamide

**Note:** Specifications and materials listed above are for switches with standard options. For information on specific and custom switches, consult Customer Service Center. For Tin Lead options consult customer service center.

## How To Order

The Build-A Switch concept allows you to mix and match options to create the switch you need. Below is a complete listing of options shown in catalog. To order, simply select desired option from each category and place in the appropriate box.

All switches supplied in "OFF" position..

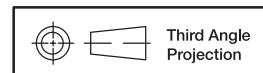
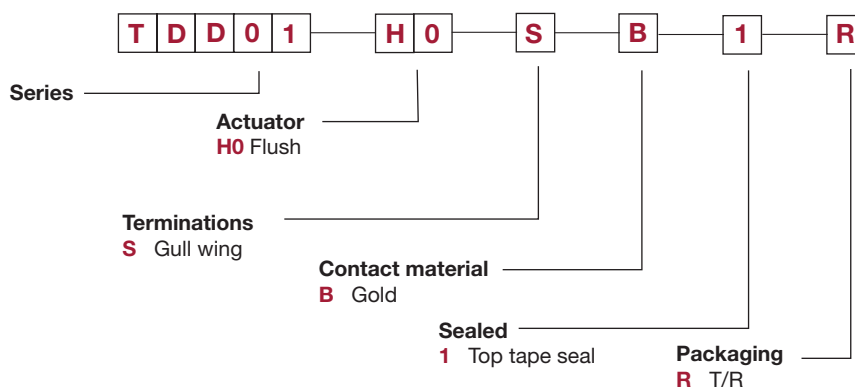

Third Angle  
Projection

Dimensions are shown: Inch (mm)  
Specifications and dimensions subject to change

# TDD Series Jumper Switch



DIP I

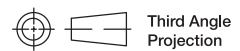
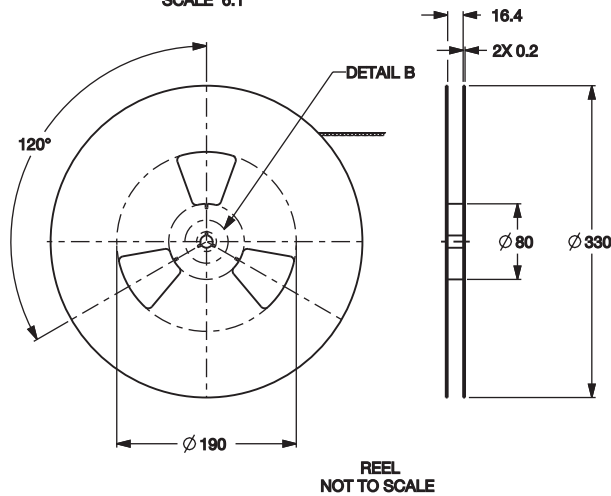
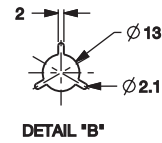
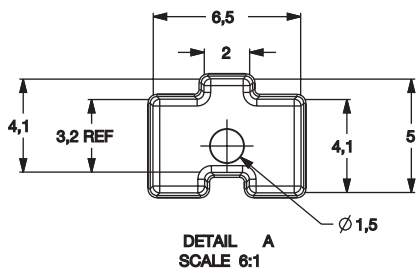
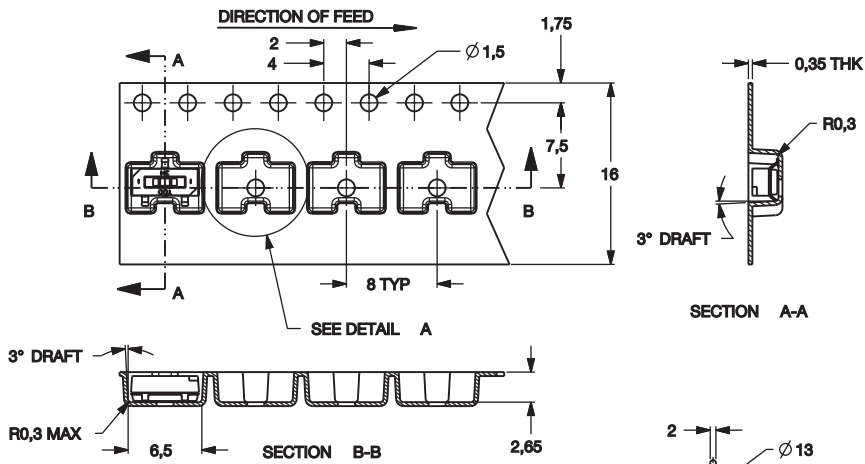
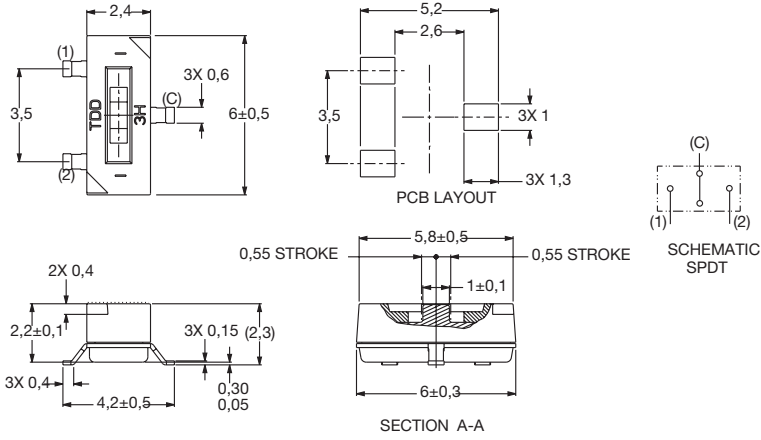

Dimensions are shown: Inch (mm)  
Specifications and dimensions subject to change