

AVERY DENNISON MARKETING SPECIFICATION

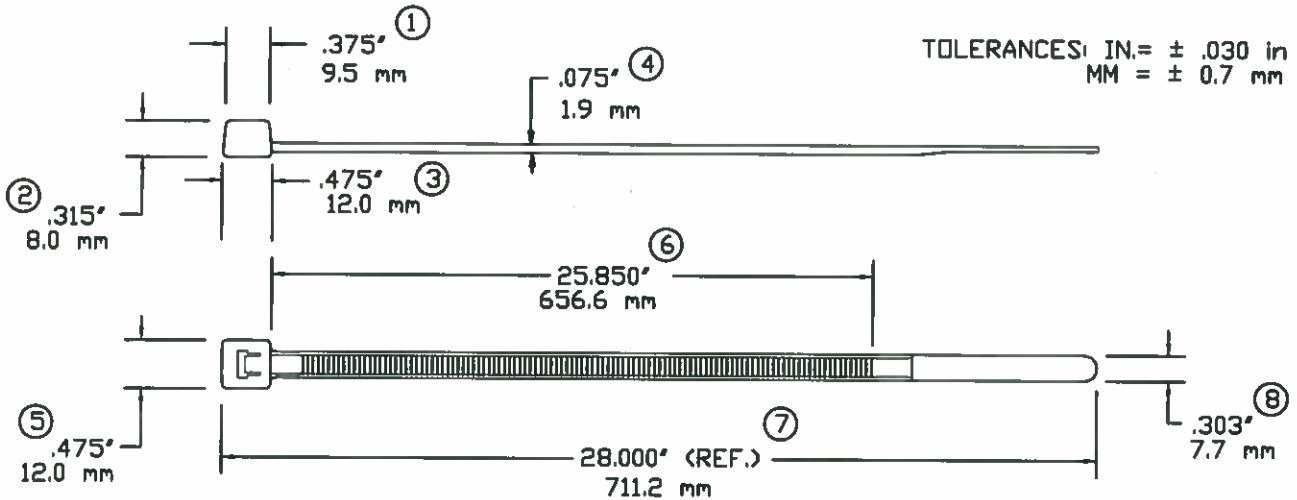

NOT TO SCALE

LOOP TENSILE STRENGTH:	120 LBF / 534N MINIMUM PER AS-23190
OPERATING TEMPERATURE:	-40°F(-40°C) TO 176°F(80°C)
MIN. INSTALLATION TEMP:	32°F(0°C)
MATERIAL:	NYLON 6/6
WEIGHT:	.377 oz. / 10.68 grams
MILITARY STANDARD:	MS-3367-6-0
BUNDLE DIAMETER:	Ø.250"/4.76mm TO Ø8.0"/203.2mm
TOOL TENSION SETTING:	6-8 ON HEAVY DUTY TOOL
PACKAGED IN:	50/BAG, 1,000/CASE

NOTE: THESE CABLE TIES ARE UV RESISTANT AND HAVE A FLAMMABILITY RATING OF V-2.

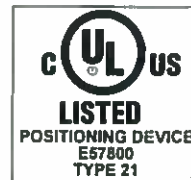

FASTENER DIVISION
FITCHBURG, MA 01420 U.S.A.
TEL. 1-800-225-5913
FAX. 1-800-848-2169

DESCRIPTION:

28" / 711mm CABLE TIE, HEAVY DUTY
BLACK WEATHER RESISTANT

APPROVAL:

J. Boyle 9-15-2015

STOCK NO.

10620-0

REV

F