



# GOODRAM Commercial mSATA SSD

## 128 GB S11 MLC

### DATASHEET



Version: 1.0  
Date: September 2017

mSATA Solid State Drive with SATA interface for Commercial Applications

Wilk Elektronik S.A.  
Mikołowska 42  
43-173 Łaziska Górne, Poland  
Tel.: +48 32 736 90 00, Fax.: +48 32 736 90 01  
E-mail: [sales@goodram.com](mailto:sales@goodram.com)



All rights are strictly reserved. Any portion of this paper shall not be reproduced, copied, or translated to any other forms without permission from Wilk Elektronik S.A.

This document is subject to change without any notice.

Please contact your Wilk Elektronik S.A. sales representative for details as to environmental matters such as the RoHS compatibility of Product. Please use Product in compliance with all applicable laws and regulations that regulate the inclusion or use of controlled substances, including without limitation, the EU RoHS Directive. Wilk Elektronik S.A. assumes no liability for damages or losses occurring as a result of noncompliance with applicable laws and regulations.



## REVISION HISTORY

VERSION	CHANGES	DATE
1.0	Initial release	19.09.2017



## TABLE OF CONTENTS

<b>PRODUCT OVERVIEW .....</b>	<b>4</b>
<b>PRODUCT DETAILS .....</b>	<b>5</b>
<b>GENERAL DESCRIPTION .....</b>	<b>5</b>
<b>FLASH MANAGEMENT .....</b>	<b>5</b>
<b>ADDITIONAL FEATURES .....</b>	<b>6</b>
<b>PRODUCT ORDERING INFORMATION .....</b>	<b>8</b>
<b>PERFORMANCE AND POWER CONSUMPTION.....</b>	<b>9</b>
<b>SUPPLY VOLTAGE .....</b>	<b>10</b>
<b>TBW .....</b>	<b>11</b>
<b>PIN ASSIGNMENT AND DESCRIPTIONS .....</b>	<b>12</b>
<b>SUPPORTED ATA COMMAND LIST.....</b>	<b>13</b>
<b>PHYSICAL DIMENSION .....</b>	<b>15</b>
<b>STANDARDS &amp; REFERENCES.....</b>	<b>16</b>
<b>SAFETY PRECAUTIONS.....</b>	<b>16</b>
<b>NOTES ON USAGE .....</b>	<b>17</b>



## PRODUCT OVERVIEW

- Capacity
  - 128 GB
- SATA Interface
  - SATA Revision 3.2
  - SATA 1.5Gbps, 3Gbps and 6Gbps interface
- Flash Memory
  - Flash Type: MLC
  - 1pcs to 4pcs of TSOP/BGA flash
- Performance
  - Read: up to 560 MB/s
  - Write: up to 465 MB/s
- Power Consumption<sup>Note1</sup>
  - Active mode: < 2485mW
  - Idle mode: < 265mW
  - DEVSLP mode: < 5mW
- TBW (terabytes written)<sup>Note2</sup>
  - 181 TBW for 128GB
- MTBF
  - More than 2,000,000 hours
- Advanced Flash Management
  - Static and Dynamic Wear Leveling
  - Bad Block Management
  - TRIM
  - SMART
  - Over-provisioning
  - Firmware update
  - SmartZIP™
- Low Power Management
  - DIPM/HIPM Mode
  - DEVSLP Mode (optional)
- Temperature Range
  - Operational: 0 ~+ 70°C
  - Storage: -40°C ~ +85°C
- RoHS compliant

### Notes:

1. Please see “Power Consumption” for details.
2. Please see “TBW (Terabyte Written)” for details.



## PRODUCT DETAILS

### GENERAL DESCRIPTION

GOODRAM Commercial mSATA SSD delivers all the advantages of Flash Drive technology with Serial ATA I/II/III interface and is fully compliant with the standard mSATA form factor. The mSATA SSD is designed to operate at a maximum operating frequency of 200MHz with 30MHz external crystal. The performance reach up to 550MB/s read as well as 500MB/s write based on Toggle 2.0 MLC (with 32MB SDR cache enabled and measured by CrystalDiskMark). Meanwhile, the power consumption is much lower than traditional Hard Drives.

### FLASH MANAGEMENT

GOODRAM Commercial mSATA MLC SSD utilizes all the state of art technologies to ensure full reliability until the TBW parameter is reached. These technologies include:

#### Error Correction Code (ECC)

Flash memory cells will deteriorate with use, which might generate random bit errors in the stored data. Thus, SSD drive applies the LDPC (Low Density parity Check) of ECC algorithm, which can detect and correct errors occur during read process, ensure data been read correctly, as well as protect data from corruption.

#### Wear Leveling

NAND Flash devices can only undergo a limited number of program/erase cycles, and in most cases, the flash media are not used evenly. If some area get updated more frequently than others, the lifetime of the device would be reduced significantly. Thus, Wear Leveling technique is applied to extend the lifespan of NAND Flash by evenly distributing write and erase cycles across the media. Product has advanced Wear Leveling algorithm, which can efficiently spread out the flash usage through the whole flash media area. Moreover, by implementing both dynamic and static Wear Leveling algorithms, the life expectancy of the NAND Flash is greatly improve

#### Bad Block Management

Bad blocks are blocks that include one or more invalid bits, and their reliability is not guaranteed. Blocks that are identified and marked as bad by the manufacturer are referred to as "Initial Bad Blocks". Bad blocks that are developed during the lifespan of the flash are named "Later Bad Blocks". We implement an efficient bad block management algorithm to detect the factory-produced bad blocks and manages any bad blocks that appear with use. This practice further prevents data being stored into bad blocks and improves the data reliability.



## TRIM

TRIM is a feature which helps improve the read/write performance and speed of solid-state drives (SSD). Unlike hard disk drives (HDD), SSDs are not able to overwrite existing data, so the available space gradually becomes smaller with each use. With the TRIM command, the operating system can inform the SSD which blocks of data are no longer in use and can be removed permanently. Thus, the SSD will perform the erase action, which prevents unused data from occupying blocks all the time.

## SMART

SMART, an acronym for Self-Monitoring, Analysis and Reporting Technology, is an open standard that allows a hard disk drive to automatically detect its health and report potential failures. When a failure is recorded by SMART, users can choose to replace the drive to prevent unexpected outage or data loss. Moreover, SMART can inform users of impending failures while there is still time to perform proactive actions, such as copy data to another device.

## Over-Provision

Over Provisioning refers to the inclusion of extra NAND capacity in a SSD, which is not visible and cannot be used by users. With Over Provisioning, the performance and IOPS (Input/Output Operations per Second) is improved by providing the controller additional space to manage P/E cycles, which enhances the reliability and endurance as well. Moreover, the write amplification of the SSD becomes lower when the controller writes data to the flash.

## Firmware Upgrade

Firmware can be considered as a set of instructions on how the device communicates with the host. Firmware will be upgraded when new features are added, compatibility issues are fixed, or read/write performance gets improved.

## ADDITIONAL FEATURES

### Low Power Management (DIPM/HIPM Mode)

SATA interfaces contain two low power management states for power saving: Partial and Slumber modes. For Partial mode, the device has to resume to full operation within 10 microseconds, whereas the device will spend 10 milliseconds to become fully operational in the Slumber mode. SATA interfaces allow low power modes to be initiated by Host (HIPM, Host Initiated Power Management) or Device (DIPM, Device Initiated Power Management). As for HIPM, Partial or Slumber mode can be invoked directly by the software. For DIPM, the device will send requests to enter Partial or Slumber mode.

### DEVSLP Mode (optional)

With the increasing need of aggressive power/battery life, SATA interfaces include a new feature, Device Sleep (DEVSLP) mode, which helps further reduce the power consumption of the device. DEVSLP enables



the device to completely power down the device PHY and other sub-systems, making the device reach a new level of lower power operation. The DEVSLP does not specify the exact power level a device can achieve in the DEVSLP mode, but the power usage can be dropped down to 5mW or less.

#### Power Loss Protection: Flushing Mechanism

Power Loss Protection is a mechanism to prevent data loss during unexpected power failure. DRAM is a volatile memory and frequently used as temporary cache or buffer between the controller and the NAND flash to improve the SSD performance. However, one major concern of the DRAM is that it is not able to keep data during power failure. Accordingly, the controller applies the GuaranteedFlush Technology, which requests the controller to transfer data to the cache. For the used controller, SDR performs as a cache, and its sizes include up to 32MB. Only when the data is fully committed to the NAND flash will the controller send acknowledgement (ACK) to the host. Such implementation can prevent false-positive performance and the risk of power cycling issues.

Additionally, it is critical for a controller to shorten the time the in-flight data stays in the cache. Thus, the controller applies an algorithm to reduce the amount of data resides in the cache to provide a better performance. This SmartCacheFlush technology allows incoming data to only have a “pit stop” in the cache and then move to the NAND flash at once. If the flash is jammed due to particular file sizes (random 4K), the cache will be treated as an “organizer”, consolidating incoming data into groups before written into the flash to improve write amplification.

In sum, with this Flush Management, the controller proves to provide the reliability required by consumer, industrial, and enterprise-level application.

#### Advanced Device Security Features (Secure Erase, Write Protect)

Secure Erase is a standard ATA command and will write all “0x00” to fully wipe all the data on hard drives and SSDs. When this command is issued, the SSD controller will empty its storage blocks and return to its factory default settings. When a SSD contains too many bad blocks and data are continuously written in, then the SSD might not be used anymore. Thus, Write Protect is a mechanism to prevent data from being written in and protect the accuracy of data that are already stored in the SSD.





## PRODUCT ORDERING INFORMATION

GOODRAM PN	AAEON PN	Type	Capacity	Technology	Temp range	Grade
SSDPB-I4000-128	EP-SSMSF128GRUP	mSATA	128GB	MLC	0~70°C	Commercial



## PERFORMANCE AND POWER CONSUMPTION

Capacity	Flash Structure	Performance				Power Consumption		
		CrystalDiskMark		ATTO		Read (mW)	Write (mW)	DEVSLP (mW)
		Read (MB/s)	Write (MB/s)	Read (MB/s)	Write (MB/s)			
120/128GB	32GBx4, TSOP, 15nm	560	465	560	540	1,170	1,525	4.9
120/128GB	64GBx2, BGA, 15nm	560	465	560	540	1,240	1,430	4.9
120/128GB	32GBx4, TSOP, L06B	300	300	550	540	1,350	1,850	4.9
120/128GB	32GBx4, BGA, L06B	550	490	550	540	1,285	1,865	4.9
120/128GB	64GBx2, BGA, L06B	525	480	550	540	1,170	1,580	4.9
120/128GB	128GBx1, BGA, L06B	550	490	550	540	1,065	1,530	4.9

### NOTES:

1. The performance was measured using CrystalDiskMark with SATA 6Gbps host.
2. Performance may differ according to flash configuration and platform.
3. The table above is for reference only. The criteria for MP (mass production) and for accepting goods shall be discussed based on different flash configuration.



## SUPPLY VOLTAGE

PARAMETER	RATING
Operating voltage	3.3V +/- 5%



## TBW

Capacity	Flash Structure	TBW
120/128GB	32GB x 4, 64GB x 2, 128GB x 1	181

### NOTES:

1. Samples were built using Toshiba 15nm/Micron 16nm/Spectek 16nm MLC NAND.
2. TBW may differ according to flash configuration and platform.
3. The endurance of SSD could be estimated based on user behavior, NAND endurance cycles, and write amplification factor. It is not guaranteed by flash vendor.

TBW (Terabytes Written) is a measurement of SSDs' expected lifespan, which represents the amount of data written to the device. To calculate the TBW of a SSD, the following equation is applied:

$$TBW = [(NAND\ Endurance) \times (SSD\ Capacity) \times (WLE)] / WAF$$

NAND Endurance: NAND endurance refers to the P/E (Program/Erase) cycle of a NAND flash.

SSD Capacity: The SSD capacity is the specific capacity in total of a SSD.

WLE: Wear Leveling Efficiency (WLE) represents the ratio of the average amount of erases on all the blocks to the erases on any block at maximum.

WAF: Write Amplification Factor (WAF) is a numerical value representing the ratio between the amount of data that a SSD controller needs to write and the amount of data that the host's flash controller writes. A better WAF, which is near 1, guarantees better endurance and lower frequency of data written to flash memory.

## PIN ASSIGNMENT AND DESCRIPTIONS

Pin #	mSATA Pin	Description
1	NC	No Connect
2	+3.3V	3.3V Source
3	NC	No Connect
4	DGND	Digital GND
5	NC	No Connect
6	NC	No Connect
7	NC	No Connect
8	NC	No Connect
9	DGND	Digital GND
10	NC	No Connect
11	NC	No Connect
12	NC	No Connect
13	NC	No Connect
14	NC	No Connect
15	DGND	Digital GND
16	NC	No Connect
17	NC	No Connect
18	DGND	Digital GND
19	NC	No Connect
20	NC	No Connect
21	SATA GND	SATA Ground Return Pin
22	NC	No Connect
23	TXP (out)	Host Receiver Differential Signal Pair
24	+3.3V	3.3V Source
25	TXN (out)	Host Receiver Differential Signal Pair
26	SATA GND	SATA Ground Return Pin
27	SATA GND	SATA Ground Return Pin
28	NC	No Connect
29	SATA GND	SATA Ground Return Pin
30	NC	No Connect
31	RXN (in)	Host Transmitter Differential Signal Pair
32	NC	No Connect
33	RXP (in)	Host Transmitter Differential Signal Pair

34	DGND	Digital GND
35	SATA GND	SATA Ground Return Pin
36	NC	No Connect
37	SATA GND	SATA Ground Return Pin
38	NC	No Connect
39	+3.3V	3.3V Source
40	DGND	Digital GND
41	+3.3V	3.3V Source
42	NC	No Connect
43	NC	No Connect
44	DEVSLP	Enter/Exit DevSleep
45	NC	Reserved pin
46	NC	No Connect
47	NC	Reserved pin
48	NC	No Connect
49	DAS	Device Activity Signal
50	DGND	Digital GND
51	GND	Default connect to GND
52	+3.3V	3.3V Source

## SUPPORTED ATA COMMAND LIST

Op-Code	Command Description	Op-Code	Command Description
00h	NOP	C9h	Read DMA without Retry
06h	Data Set Management	CAh	Write DMA
10h-1Fh	Recalibrate	CBh	Write DMA without Retry
20h	Read Sectors	CEh	Write Multiple FUA EXT
21h	Read Sectors without Retry	E0h	Standby Immediate
24h	Read Sectors EXT	E1h	Idle Immediate
25h	Read DMA EXT	E2h	Standby
27h	Read Native Max Address EXT	E3h	Idle
29h	Read Multiple EXT	E4h	Read Buffer
2Fh	Read Log EXT	E5h	Check Power Mode
30h	Write Sectors	E6h	Sleep
31h	Write Sectors without Retry	E7h	Flush Cache
34h	Write Sectors EXT	E8h	Write Buffer
35h	Write DMA EXT	E9h	READ BUFFER DMA
37h	Set Native Max Address EXT	EAh	Flush Cache EXT
38h	CFA Write Sectors Without Erase	EBh	Write Buffer DMA

39h	Write Multiple EXT		ECh		Identify Device
3Dh	Write DMA FUA EXT		EFh		Set Features
3Fh	Write Long EXT		EFh	02h	Enable volatile write cache
40h	Read Verify Sectors		EFh	03h	Set transfer mode
41h	Read Verify Sectors without Retry		EFh	05h	Enable the APM feature set
42h	Read Verify Sectors EXT		EFh	10h	Enable use of SATA features et
44h	Zero EXT		EFh	10h 02h	Enable DMA Setup FIS Auto-Activate optimization
45h	Write Uncorrectable EXT		EFh	10h 03h	Enable Device-initiated interface power state (DIPM) transitions
47h	Read Log DMA EXT		EFh	10h 06h	Enable Software Settings Preservation (SSP)
57h	Write Log DMA EXT		EFh	10h 07h	Enable Device Automatic Partial to Slumber transitions
60h	Read FPDMA Queued		EFh	10h 09h	Enable Device Sleep
61h	Write FPDMA Queued		EFh	55h	Disable read look-ahead
70h-7Fh	Seek		EFh	66h	Disable reverting to power-on defaults
90h	Execute Device Diagnostic		EFh	82h	Disable volatile write cache
91h	Initialize Device Parameters		EFh	85h	Disable the APM feature set
92h	Download Microcode		EFh	90h	Disable use of SATA feature set
93h	Download Microcode DMA		EFh	90h 02h	Disable DMA Setup FIS Auto-Activate optimization
B0h	SMART		EFh	90h 03h	Disable Device-initiated interface power state (DIPM) transitions
B0h	D0h	EFh	EFh	90h 06h	Disable Software Settings Preservation (SSP)
B0h	D1h	EFh	EFh	90h 07h	Disable Device Automatic Partial to Slumber transitions
B0h	D2h	EFh	EFh	90h 09h	Disable Device Sleep
B0h	D3h	SMART SAVE ATTRIBUTE VALUES	EFh	AAh	Enable read look-ahead
B0h	D4h	SMART EXECUTE OFF-LINE IMMEDIATE	EFh	CCh	Enable reverting to power-on defaults
B0h	D5h	SMART READ LOG	F1h		Security Set Password
B0h	D6h	SMART WRITE LOG	F2h		Security Unlock
B0h	D8h	SMART ENABLE OPERATIONS	F3h		Security Erase Prepare
B0h	D9h	SMART DISABLE OPERATIONS	F4h		Security Erase Unit
B0h	DAh	SMART RETURN STATUS	F5h		Security Freeze Lock
B0h	DBh	SMART ENABLE/DISABLE AUTOMATIC OFF-LINE	F6h		Security Disable Password
B1h	Device Configuration		F8h		Read Native Max Address
B4h	Sanitize		F9h		Set Max Address
C4h	Read Multiple		F9h	01h	SET MAX SET PASSWORD
C5h	Write Multiple		F9h	02h	SET MAXLOCK
C6h	Set Multiple Mode		F9h	03h	SET MAX UNLOCK
C8h	Read DMA		F9h	04h	SET MAX FREEZE LOCIK

# PHYSICAL DIMENSION

Dimension: 50.8mm (L) x 29.85mm (W) x 4.00mm (H)

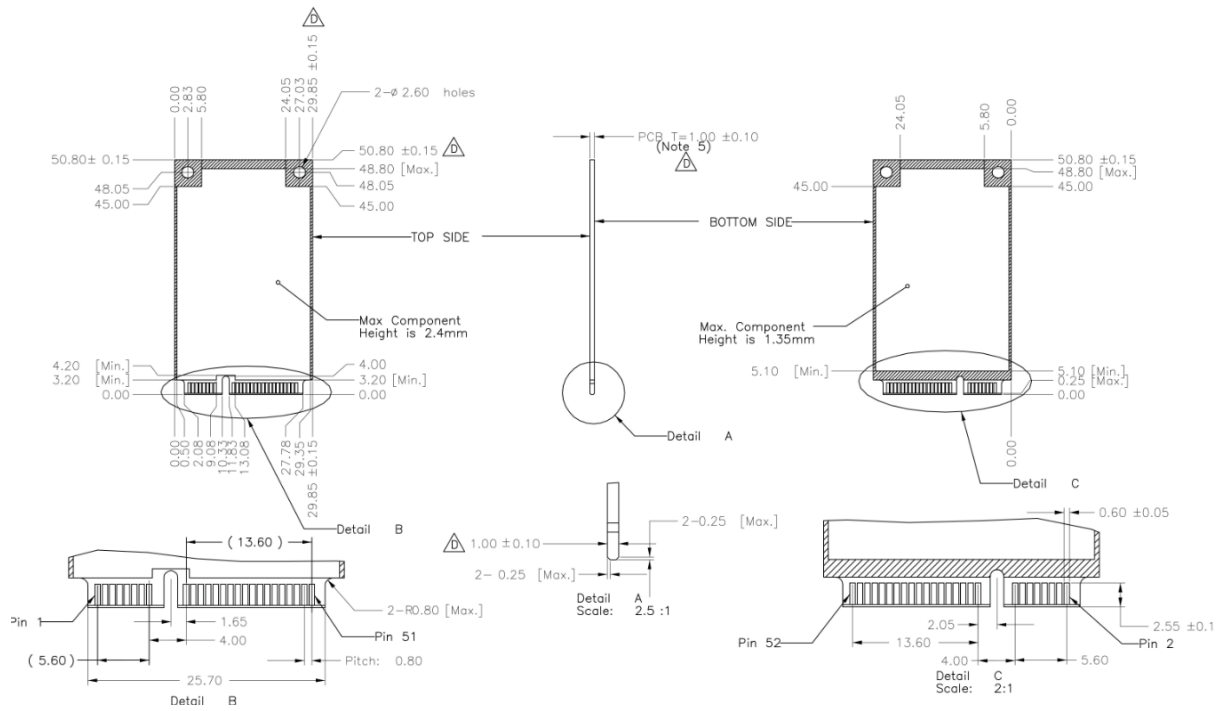





## STANDARDS & REFERENCES

The following table is to list out the standards that have been adopted for designing the product.

STANDARD USED	ACRONYM/SOURCE
RoHS	Restriction of Hazardous Substances Directive; please contact us for further information
Serial ATA Revision 3.2	<a href="http://www.sata-io.org">http://www.sata-io.org</a>
ATA-8 spec	<a href="http://www.t13.org">http://www.t13.org</a>
CE	Consumer electronics certification; please contact us for further information.

## SAFETY PRECAUTIONS

Do not bend, crush, drop, or place heavy objects on top of the Product. Do not use tweezers, pliers, or similar items that could damage the Product. Take particular care when inserting or removing the Product. Stop using the Product when the Product does not work properly. Failure to follow these instructions could result in fire, damage to the Product and/or other property, and/or personal injury including burns and electric shock.

Keep out of reach of small children. Accidental swallowing may cause suffocation or injury. Contact a doctor immediately if you suspect a child has swallowed the Product. .

Do not directly touch the interface pins, put them in contact with metal, strike them with hard objects, or cause them to short. Do not expose to static electricity.

Do not disassemble or modify the Product. This may cause electric shock, damage to the Product, or fire.



## NOTES ON USAGE

The Product contains nonvolatile semiconductor memory. Do not use the Product in accordance with a method of usage other than that written in the manual. This may cause the destruction or loss of data.

To protect against accidental data loss, you should back up your data frequently on more than one type of storage media. Wilk Elektronik S.A. assumes no liability for destruction or loss of data recorded on the Card for any reason.

When used over a long period of time or repeatedly, the reading, writing and deleting capabilities of the Product will eventually fail, and the performance speed of the Product may decrease below the original speed specific to the Product's applicable class.

If the Product is to be transferred or destroyed, note that the data it contained may still be recoverable unless it is permanently deleted by third-party deletion software or similar means beforehand.

Product is intended for use in general electronics applications. Product is neither intended nor warranted for use in equipment or systems where failure may cause loss of human life, bodily injury, serious property damage or serious public impact ("Unintended Use"). Unintended Use includes, without limitation, equipment used in nuclear facilities, equipment used in the aerospace industry, medical equipment or equipment used to control combustions or explosions. Do not use Product for Unintended Use unless specifically permitted in this document.

No parts of this document may be reproduced, stored in a retrieval system, or transmitted, in any form or by any means, mechanical, electric, photocopying, recording or otherwise, without permission of Wilk Elektronik S.A.

Wilk Elektronik S.A does not make any warranty, express or implied, with respect to this document, including as to licensing, Non-infringement, merchantability or fitness for a particular purpose.