

WIRE WELL DATA		
CONTACT SIZE	16	20
WELL DIA	.063 <sup>+.004</sup> / <sub>-.001</sub>	.047±.001
WELL DEPTH <sup>+.031</sup> / <sub>-.000</sub>	.250	.250

10/12/90		REVISIONS	70090-387	
ZONE	LTR	DESCRIPTION	DATE	APPROVED
	B	(CL II) SEE CHANGE NOTICE ECN:25597	11/12/90 PRESCOTT	<i>P</i>

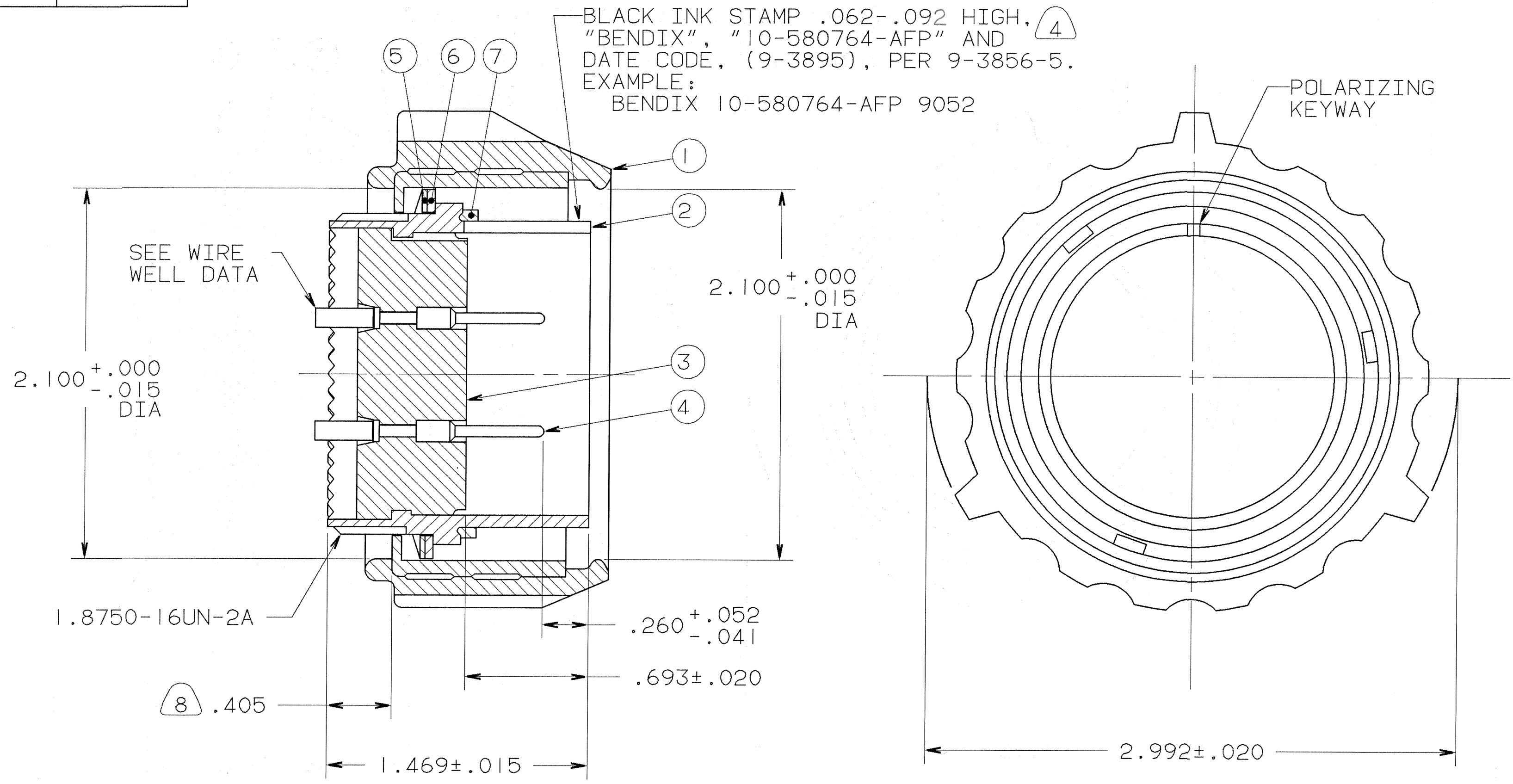

- 8. MAX ACCESSORY LENGTH.
- 7. PACKAGE PER PRODUCTION PROCESS SHEET.
- 6. DRAWING ILLUSTRATES FINAL ASSEMBLY. FOR STORAGE AND SHIPPING COUPLING NUT MUST BE CONTAINED ON SHELL. CONTACTS ARE SHIPPED UNASSEMBLED.
- 5. PROCESS SPEC:  
ASSY 9-4351-4  
TEST 9-3106-18  
9-3895, 9-3856-5
- 4. SEE WORK ORDER FOR PERMISSIBLE ADDITIONAL OR ALTERNATE STAMPING.
- 3. INSERTS ARE NOT REMOVABLE.
- 2. FOR CONTACT SIZE, SPACING AND SERVICE RATING, SEE L-11932-AF.
- 1. UNIT MEETS THE APPLICABLE REQUIREMENTS OF MIL-C-5015.

NOTES:  
THE USE OF THIS DOCUMENT IS UNLIMITED. HOWEVER, DOCUMENTS REFERENCED HEREON MAY CONTAIN LIMITED RIGHTS DATA.

COMPANY ID: 2  
CODED/MS/CUST: N  
INTERNAL: Y  
LOTNO: N  
DATE CODE: 9-3895  
SEE PRINT: Y

UNLESS OTHERWISE SPECIFIED LINEAR DIMENSIONS ARE IN INCHES.  
TOLERANCES: .XXX±.010,  
.XX ±.03, .X ±.1,  
ANGLES ±2°.  
OTHER STANDARDS PER 9-3800 AND DOD-D-1000.  
NOTE REF. = *XX*

FIND NO.	QTY REQD.	FSCM NO.	PART NUMBER	DESCRIPTION	NOTE REF.
7	1		10-564842-321	GASKET	
6	1		10-564860-32	WASHER, FLAT	
5	1		10-564859-32	WASHER, WAVED	
4	55		10-407188-191	CONTACT	
3	1		10-401532-AFP	INSERT	
2	1		10-580915-323	SHELL	
1	1		10-564858-32	COUPLING NUT	

SPECIFICATIONS		SIGNATURES		DATES		PARTS LIST	
MATERIAL SPEC.	N/A	PREPARED	SNYDER	6-21-90	AMPHENOL CORPORATION BENDIX CONNECTOR OPERATIONS SIDNEY, N.Y.		
		CHECKED	MACAVOY	10/17/91	CONNECTOR, ELECTRICAL PLUG, REVERSE BAYONET COUPLING, GTCY06CD SPECIAL, SIZE 32		
		MATERIAL	DOWNIE	10/15/90	SIZE	FSCM NO.	REV.
PROCESS SPEC.	SEE NOTE 5	APPROVED	SNYDER	10/18/90	C	77820	B
		APPROVED	MACAVOY	10/12/90	SCALE	2/1	WT.
		1ST PART NO.	10-580764-AFP		REF	71-580750/769	SHEET 1 OF 1