

PRODUCT NO.
10108777-X0XXXX

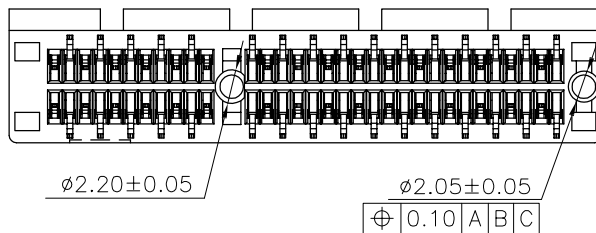

SECTION P-P

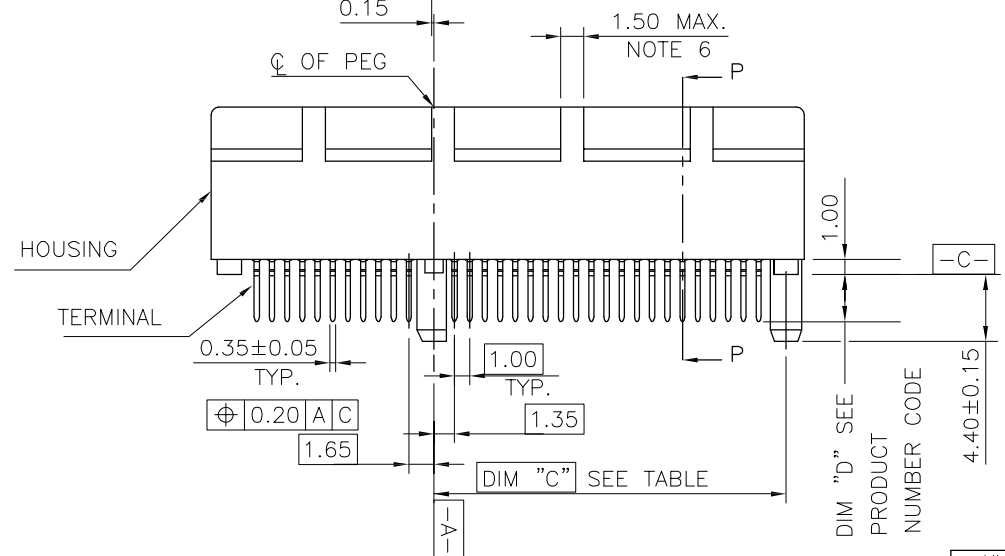
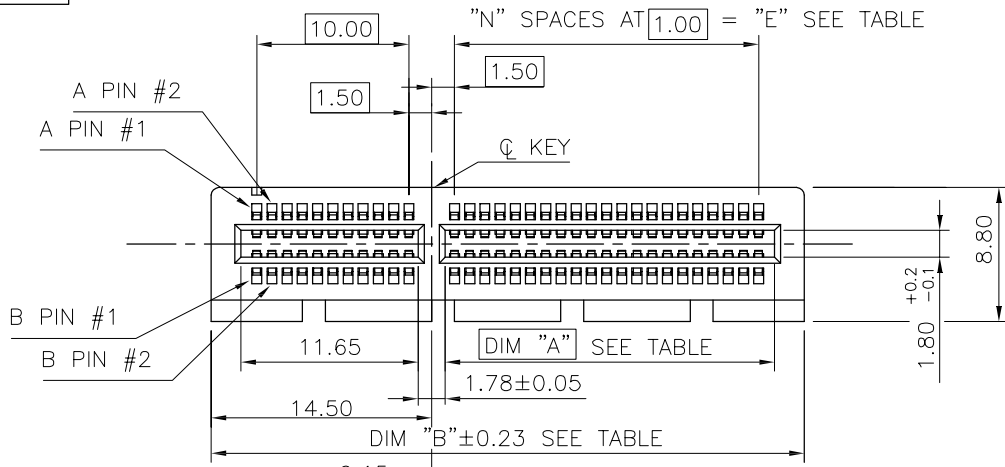
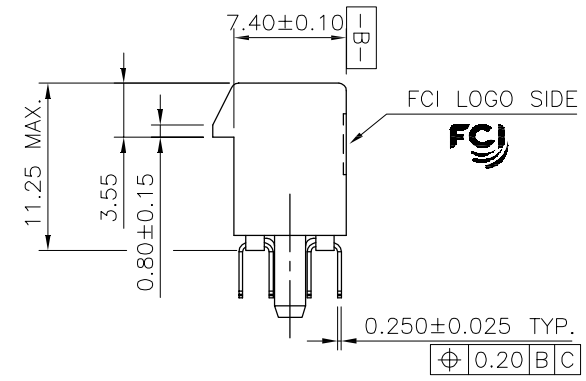

TWIN PLASTIC PEG TYPE

mat'l. code		surface		tolerance		projection		product family	
-		-		ASME_Y14.5		MM		PCI_EXPRESS	
tolerances unless otherwise specified									
lfr	ecn no	dr	date	angles	LineGr	MM		title	
C	DG-011582	HT	5/10/12		.02 ± 0.30			PCI_EXPRESS_CARD_EDGE_GEN3	
D	ELX-DG-013209	WL	07/24/12		.00 ± 0.20			TH_ASS'Y	
E	ELX-DG-2181-1	ST	05/27/15	± 2'	.000 ± 0.10	scale N/A		dwg no	
F	ELX-DG-24164	ZH	05/30/16	dr	ZHENHUA_LIU	2016-03-30		sheet 1 of 7 size	
G	ELX-DG-25671	ZH	12/18/16	enfr	ZHENHUA_LIU	2016-03-30		10108777	
H	ELX-DG-27937	ZH	09/12/17	chr	STONE_LI	2016-03-30		A4	
				appd		PM_ZHENG		2016-03-30	
sheet index		revision sheet		H				type	
								CUSTOMER Drawing	

PRODUCT NO.
10108777-X2XXXX



SINGLE PLASTIC PEG TYPE

mat'l. code		surface		tolerance		projection		product family	
-		-		ASME_Y14.5				PCI_EXPRESS	
lfr		ecn no		dr		date		title	
								PCI_EXPRESS_CARD_EDGE_GEN3	
								TH_ASS'Y	
								dwg no	
								10108777	
								sheet 2 of 7	
								size	
								A4	
								type	
								CUSTOMER Drawing	
sheet index		revision sheet		H					

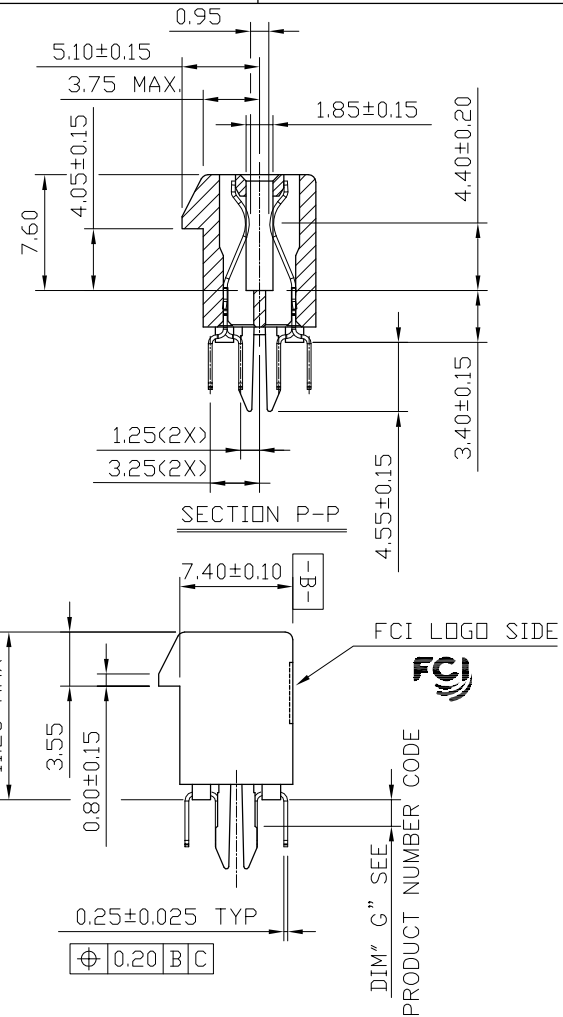
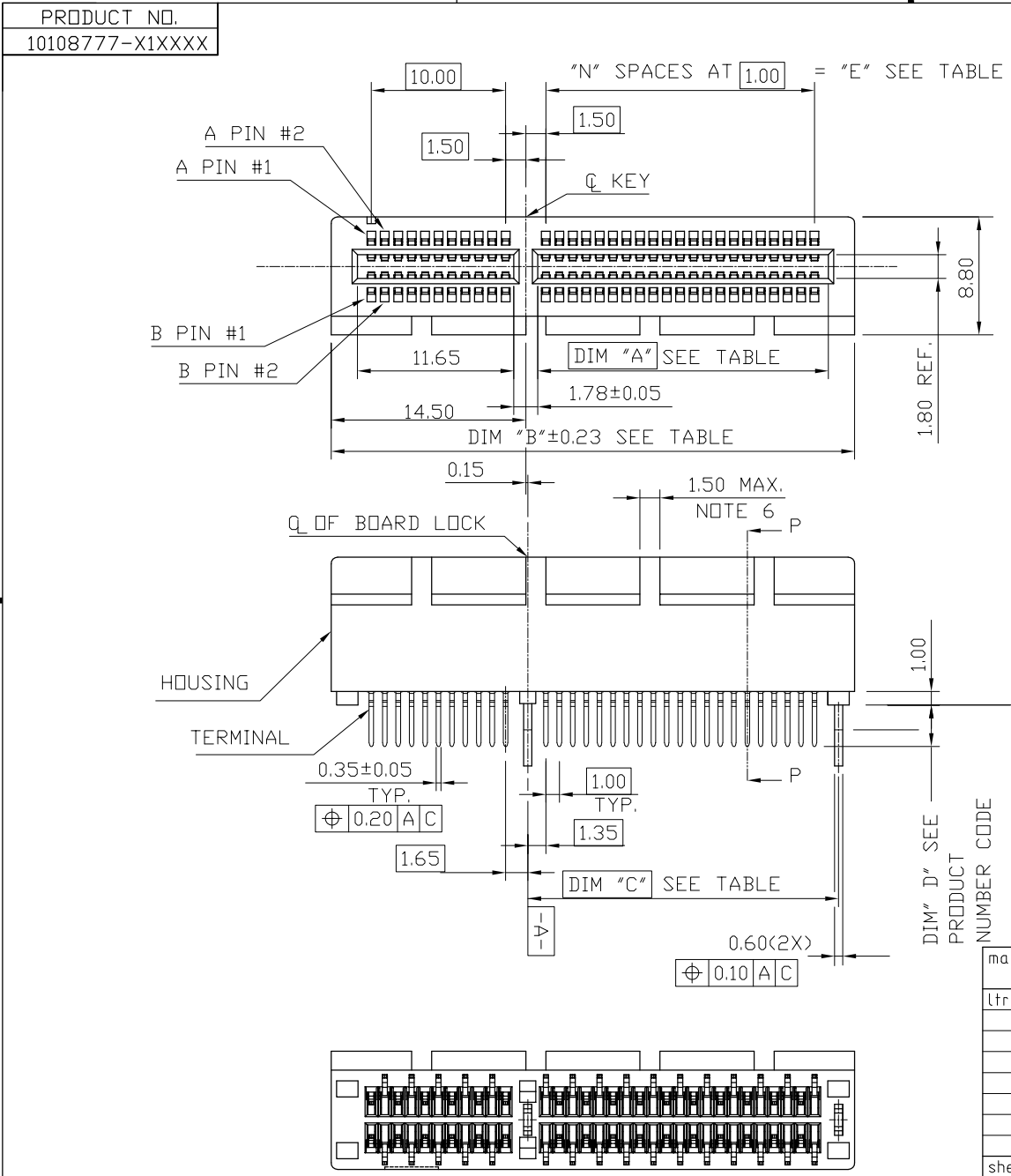

METAL BOARD LOCKS

mat'l. code		surface		tolerance		projection		product family	
-		-		ASME_Y14.5		⊕		PCI_EXPRESS	
lfr		ecn no		dr		date		title	
								PCI_EXPRESS_CARD_EDGE_GEN3	
								TH_ASS'Y	
								dwg no	
								sheet 3 of 7	
								size	
								A4	
								type	
								CUSTOMER Drawing	
sheet index		revision sheet		H					



RECOMMENDED FOOTPRINT

mat'l. code		surface		tolerance		projection		product family	
-		-		ASME_Y14.5				PCI_EXPRESS	
lfr		ecn no		dr		date		title	
								PCI_EXPRESS_CARD_EDGE_GEN3 TH_ASS'Y	
				angles				dwg no	
				±2'		scale N/A		sheet 4 of 7 size	
		dr		ZHENHUA_LIU		2016-03-30		10108777	
		enfr		ZHENHUA_LIU		2016-03-30		A4	
		chr		STONE_LI		2016-03-30		type	
		appd		PM_ZHENG		2016-03-30		CUSTOMER Drawing	
sheet index		revision sheet		H					

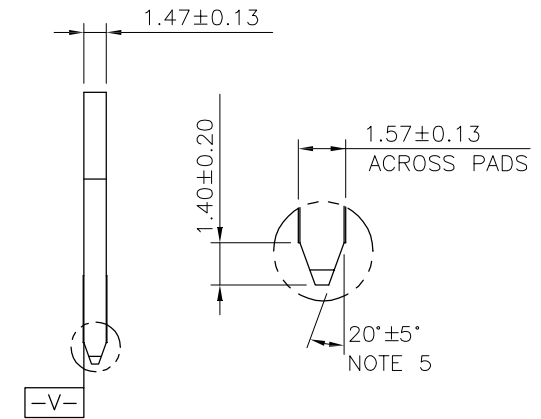

SCALE 2:1

← I/O PANEL DIRECTION
PRIMARY (COMPONENT) SIDE

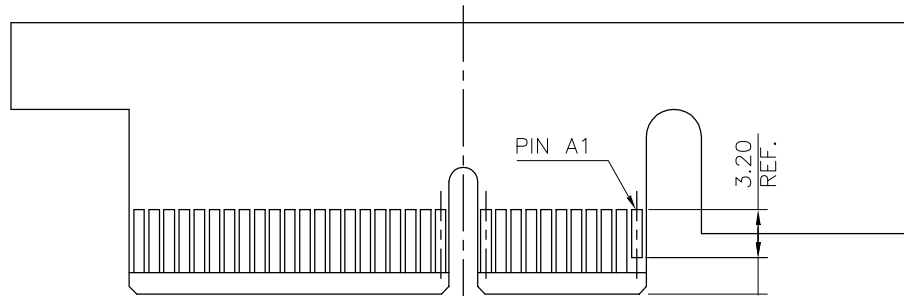

I/O PANEL DIRECTION →
SECONDARY (SOLDER) SIDE

PIN "F" SEE TABLE 2.40±0.10 NOTE 4

PIN "F" SEE TABLE 2.40±0.10 NOTE 4

#	POS REF.	N	DIM "G"	"F"
36		6	8.15	B17
64		20	22.15	B31
98		37	39.15	B48
164		70	72.15	B81

ADD-IN CARD EDGE-FINGER DIMENSIONS

mat'l. code	surface	tolerance	projection	product family
-	-	ASME_Y14.5		PCI_EXPRESS
lfr	ecn no	dr	date	tolerances unless otherwise specified
				angles
				±2'
				Line of
				±.020
				.00±.013
				.000±.005
				scale N/A
	dr	ZHENHUA_LIU	2016-03-30	
	enfr	ZHENHUA_LIU	2016-03-30	
	chr	STONE_LI	2016-03-30	
	appd	PM_ZHENG	2016-03-30	
sheet index	revision sheet	H		title
				PCI_EXPRESS_CARD_EDGE_GEN3 TH_ASS'Y
				dwg no
				10108777
				sheet 5 of 7 size
				A4
				type
				CUSTOMER Drawing

NOTES:

1.MATERIAL:

HOUSING: HIGH TEMPERATURE NYLON, GLASS FILLED UL94V-0 RATED.
TERMINAL: COPPER ALLOY.

PLATING: 50u" NICKEL UNDERPLATE ALL OVER
CONTACT AREA PLATING - SEE PRODUCT NUMBER CODE
SOLDER TAIL: TIN OR TIN /LEAD(90/10)- SEE PRODUCT NUMBER CODE 100u" MIN. OVER 50u" NICKEL.

METAL BOARD LOCKS: COPPER ALLOY.
FINISH: 100u" TIN OR TIN/LEAD(90/10) OVER 50u" NICKEL
UNDERPLATE SEE PRODUCT NUMBER CODE.

2.PRODUCT SPECIFICATION: GS-12-233.

③THE HORIZONTAL AXIS FOR THE HOLE PATTERN IS ESTABLISHED BY

A LINE THROUGH THE CENTER OF THE TWO Ø2.35 HOLES.
THE VERTICAL AXIS IS 90° TO THE HORIZONTAL AXIS, THROUGH THE CENTER OF DATUM Z.

④NO TIE BAR PERMITTED FROM CARD EDGE TO LEADING EDGE OF PAD FOR PINS A1 AND PIN NUMBERS "F".

⑤CHAMFER EDGES MUST BE FREE OF CUTTING BURRS.

⑥FREQUENCY & LOCATION AT SUPPLIER DISCRETION. RIDGE MAY BE CONTINUOUS WITH NO BREAKS.

7.RoHS COMPATIBLE PRODUCT SPECIFICATIONS:

a - PLATING:

- "LF" MEANS THE PRODUCT IS LEAD-FREE, 2um MINIMUM MATTE TIN OVER 1.27um MINIMUM NICKEL UNDERPLATE.

b - MANUFACTURING PROCESS COMPATIBILITY:

- THE HOUSING WILL WITHSTAND EXPOSURE TO 260°C±5°C TEMPERATURE FOR 10 SECONDS IN RE-FLOW APPLICATION, SEE NOTE 8 FOR APPLICATION.

PRODUCT NUMBER CODE

10108777 -X X X X X X

HOUSING COLOR OPTIONS

- 0-NATURAL
- 1-BLACK

PEGS OPTIONS

- 0-PLASTIC PEGS, DIM
- 1-METAL BOARD LOCKS
- 2-SINGLE PLASTIC PEGS

TERMINAL PLATING OPTIONS

- 0-50u" Ni UNDERPLATE
30u" Au CONTACT AREA
100u" TIN TAIL AREA ----- COMPATIBLE RoHS
- 1-50u" Ni UNDERPLATE
15u" Au CONTACT AREA
100u" TIN TAIL AREA ----- COMPATIBLE RoHS
- 2-50u" Ni UNDERPLATE
GOLD FLASH CONTACT AREA
100u" TIN TAIL AREA ----- COMPATIBLE RoHS
- 3-50u" Ni UNDERPLATE
30u" Au CONTACT AREA
100u" TIN/LEAD TAIL AREA ---INCOMPLIANT RoHS
- 4-50u" Ni UNDERPLATE
15u" Au CONTACT AREA
100u" TIN/LEAD TAIL AREA ---INCOMPLIANT RoHS
- 5-50u" Ni UNDERPLATE
GOLD FLASH CONTACT AREA
100u" TIN/LEAD TAIL AREA ---INCOMPLIANT RoHS

LEAD FREE OPTION

LEAVE BLANK FOR TERMINAL PLATING 3.4.5
"LF" FOR TERMINAL PLATING OPTION 0,1,2

POS OPTIONS

- 0-36
- 1-64
- 2-98
- 3-164

TAIL LENGTH OPTIONS

	DIM "D"	PCB THICKNESS	DIM "G"
0	2.30 ^{+0.25} / _{-0.13}	1.56±0.10	1.70±0.15
1	3.10 ^{+0.25} / _{-0.13}	2.36±0.10	2.50±0.15
2	2.54±0.25	1.56±0.10	1.70±0.15
3	1.90±0.25	1.56±0.10	1.70±0.15
4	3.10 ^{+0.25} / _{-0.13}	2.0±0.10	1.70±0.15

CONNECTOR	# POS REF.	N	DIM "A"	DIM "B"	DIM "C"	"E"
1 PORT	36	6	7.65	25.00	9.15	6.00
4 PORT	64	20	21.65	39.00	23.15	20.00
8 PORT	98	37	38.65	56.00	40.15	37.00
16 PORT	164	70	71.65	89.00	73.15	70.00

8.AN ADEQUATE PROCEDURE SET FORTH IN THE FOLLOWING ENSURE THAT THE PRODUCT RELIABILITY CAN BE ACHIEVED DURING AND AFTER PCB ASSEMBLY OPERATION.

8.1IF PARTIAL LOT ARE USED, THE REMAINING CONNECTORS MUST BE RESEALED AND PLACED IN SAFE STORAGE WITHIN SIX HOURS OF BAG OPENING.

8.2THE SAFE STORAGE CONDITION IS RECOMMENDED AT 25°C, 40%RH.

8.3NOT FOLLOWING THE PROCEDURE MAY CAUSE BLISTER DAMAGE DURING RE-FLOW PROCESS.

8.4IF BAKING IS REQUIRED, CONNECTOR SHALL BE BAKED FOR 4 HOURS AT 125°C.

8.5REFERENCE SPECIFICATION: IPC/JEDEC J-STD-033A.

PACKAGING OPTIONS

E-HARD TRAY WITH MYLAR FOR VACUUM PACKAGING (FOR 164P ONLY)

T-SOFT TRAY PACKAGING

C-SOFT TRAY PACKAGING WITH 10MM CAP

M-SOFT TRAY PACKAGING & MYLAR TAPE. SEE FIGURE 1

Y-HARD TRAY PACKAGING (FOR 36P,98P AND 164P ONLY)

Z-HARD TRAY PACKAGING WITH MYLAR (FOR 36P,98P AND 164P ONLY)

H-SMALLER HARD TRAY PACKAGING WITH 30MM CAP (323X136X17.7 FOR 164P ONLY)

△ Q-SMALLER HARD TRAY PACKAGING (323X136X17.7 FOR 164P ONLY)

R-TAPE & REEL PACKAGING WITHOUT MYLAR (FOR 34, 64, 98P ONLY)

W-TAPE & REEL PACKAGING WITHOUT MYLAR (FOR 98P ONLY), WITH 18.0MM CAVITY WIDTH

A-TAPE & REEL PACKAGING WITH MYLAR (FOR 36, 64, 98P ONLY)

mat'l. code		surface		tolerance		projection		product family	
-		-		ASME_Y14.5				PCI_EXPRESS	
lfr		ecn no		dr		date		title	
								PCI_EXPRESS_CARD_EDGE_GEN3	
								TH_ASS'Y	
								dwg no	
								sheet 6 of 7	
								size	
								A4	
								type	
								CUSTOMER Drawing	
sheet index		revision		H					



POSTION OF MYLAR

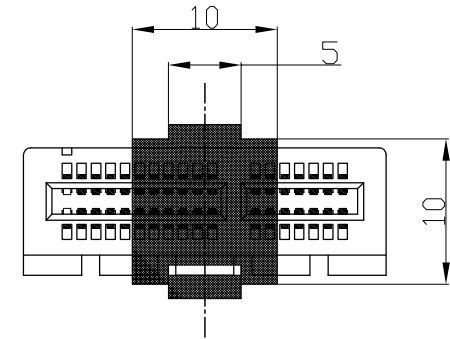

POSTION OF CAP <10x10>



POSTION OF 30MM CAP<30X12>

mat'l. code		surface		tolerance		projection		product family	
-		-		ASME_Y14.5				PCI_EXPRESS	
lfr		ecn no		dr		date		title	
								PCI_EXPRESS_CARD_EDGE_GEN3	
				angles				TH_ASS'Y	
				±2'				scale N/A	
		dr		ZHENHUA_LIU		2016-03-30		dwg no	
		enfr		ZHENHUA_LIU		2016-03-30		sheet 7 of 7	
		chr		STONE_LI		2016-03-30		size	
		appd		PM_ZHENG		2016-03-30		A4	
sheet		revision		H				type	
index		sheet						CUSTOMER Drawing	