

**TWIN PLASTIC PEG TYPE**

mat'l. code			surface		tolerance	projection	product family	
-			-		ASME_Y14.5	⊕	PCI_EXPRESS	
tolerances unless otherwise specified								title
lfr	ecn no	dr	date	angles	.02±0.30	MM	PCI_EXPRESS_CARD_EDGE_GEN3	
C	DG-011582	HT	5/10/12	Linear	.00±0.20		TH_ASS'Y	
D	ELX-DG-013209	WL	07/24/12	±2'	.000±0.10	scale N/A	5	
E	ELX-DG-2181-1	ST	05/27/15				sheet 1 of 7 size	
F	ELX-DG-24164	ZH	05/30/16	dr	ZHENHUA_LIU	2016-03-30		
G	ELX-DG-25671	ZH	12/18/16	enfr	ZHENHUA_LIU	2016-03-30		
H	ELX-DG-27937	ZH	09/12/17	chr	STONE_LI	2016-03-30		
				appd	PM_ZHENG	2016-03-30		
sheet index	revision sheet	H						dwg no
								10108777
								CUSTOMER Drawing
								A4

PRODUCT NO.  
10108777-X2XXXX

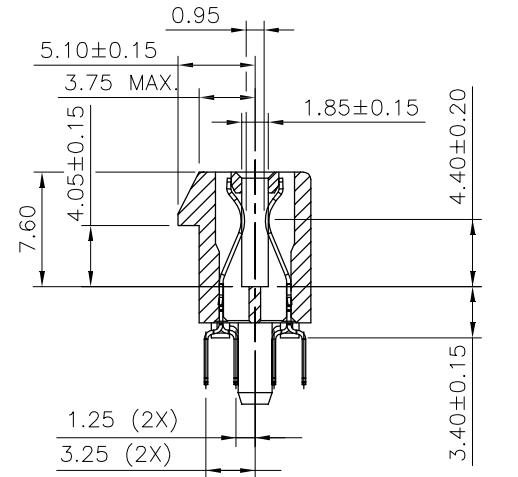

SINGLE PLASTIC PEG TYPE

mat'l. code		-		surface		- ✓		tolerance		ASME_Y14.5		projection		product family		PCI_EXPRESS	
lfr		ecn no		dr		date		tolerances unless otherwise specified		angles		LineGr		title		PCI_EXPRESS_CARD_EDGE_GEN3	
										±2'		MM		TH_ASS'Y		5	
				dr		ZHENHUA_LIU		2016-03-30		scale		N/A		dwg no		sheet 2 of 7	
				enfr		ZHENHUA_LIU		2016-03-30		Amphenol		FCI		10108777		A4	
				chr		STONE_LI		2016-03-30		type		CUSTOMER Drawing					
				appd		PM_ZHENG		2016-03-30									
sheet index		revision sheet		H													

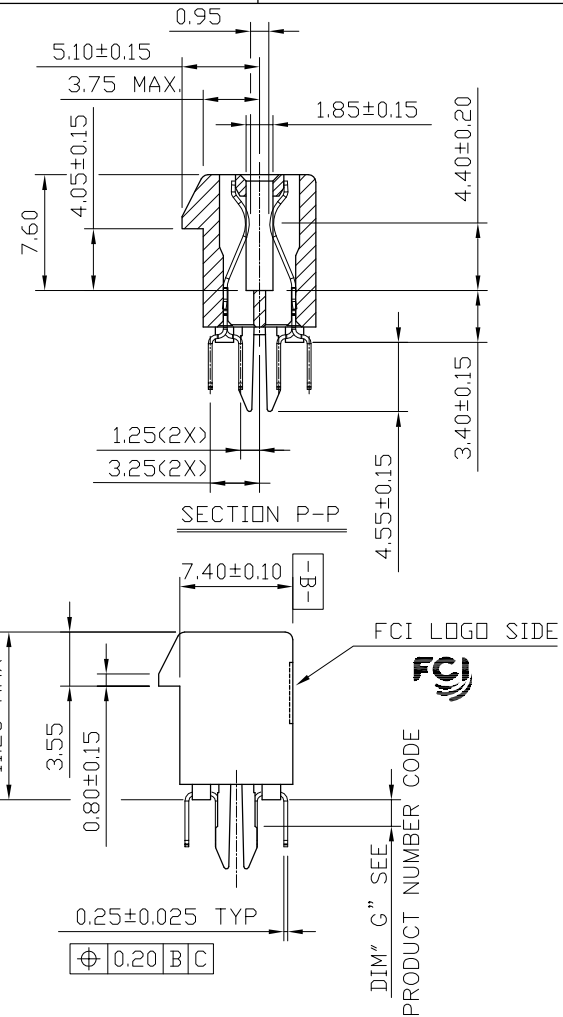

METAL BOARD LOCKS

mat'l. code	-	surface	-	tolerance	ASME_Y14.5	projection	⊕	product family	PCI_EXPRESS
lfr	ecn no	dr	date	tolerances unless otherwise specified		MM	MM	title	PCI_EXPRESS_CARD_EDGE_GEN3
				angles	Line of			TH_ASS'Y	
				±2'	.02±0.30	scale	N/A	dwg no	10108777
					.00±0.20			sheet 3 of 7	size
					.000±0.10			10108777	A4
				dr	ZHENHUA_LIU	2016-03-30	Amphenol FCI	type	CUSTOMER Drawing
				enfr	ZHENHUA_LIU	2016-03-30			
				chr	STONE_LI	2016-03-30			
				appd	PM_ZHENG	2016-03-30			
sheet index	revision sheet	H							



RECOMMENDED FOOTPRINT

mat'l. code		-		surface		- ✓		tolerance		ASME_Y14.5		projection		product family		PCI_EXPRESS	
lfr		ecn no		dr		date		tolerances unless otherwise specified		MM		title		PCI_EXPRESS_CARD_EDGE_GEN3		TH_ASS'Y	
								angles		.02±0.20		scale N/A		dwg no		sheet 4 of 7 size	
								±2'		.000±0.05		Amphenol FCI		10108777		A4	
				dr		ZHENHUA_LIU		2016-03-30						type		CUSTOMER Drawing	
				enfr		ZHENHUA_LIU		2016-03-30									
				chr		STONE_LI		2016-03-30									
				appd		PM_ZHENG		2016-03-30									
sheet index		revision sheet		H													



SCALE 2:1

← I/O PANEL DIRECTION  
PRIMARY (COMPONENT) SIDE



I/O PANEL DIRECTION →  
SECONDARY (SOLDER) SIDE

PIN "F" SEE TABLE 2.40±0.10  
NOTE 4

PIN "F" SEE TABLE 2.40±0.10  
NOTE 4

#	POS REF.	N	DIM "G"	"F"
36		6	8.15	B17
64		20	22.15	B31
98		37	39.15	B48
164		70	72.15	B81

ADD-IN CARD EDGE-FINGER DIMENSIONS

mat'l. code		surface		tolerance		projection		product family	
-		-		ASME_Y14.5		MM		PCI_EXPRESS	
lfr		ecn no		dr		date		title	
								PCI_EXPRESS_CARD_EDGE_GEN3	
								TH_ASS'Y	
								dwg no	
								sheet 5 of 7	
								size	
								A4	
								type	
								CUSTOMER Drawing	
sheet index		revision sheet		H					

NOTES:

1.MATERIAL:

HOUSING: HIGH TEMPERATURE NYLON, GLASS FILLED UL94V-0 RATED.  
TERMINAL: COPPER ALLOY.

PLATING: 50u" NICKEL UNDERPLATE ALL OVER  
CONTACT AREA PLATING - SEE PRODUCT NUMBER CODE  
SOLDER TAIL: TIN OR TIN /LEAD(90/10)- SEE PRODUCT NUMBER CODE 100u" MIN. OVER 50u" NICKEL.

METAL BOARD LOCKS: COPPER ALLOY.  
FINISH: 100u" TIN OR TIN/LEAD(90/10) OVER 50u" NICKEL  
UNDERPLATE SEE PRODUCT NUMBER CODE.

2.PRODUCT SPECIFICATION: GS-12-233.

③THE HORIZONTAL AXIS FOR THE HOLE PATTERN IS ESTABLISHED BY

A LINE THROUGH THE CENTER OF THE TWO Ø2.35 HOLES.  
THE VERTICAL AXIS IS 90° TO THE HORIZONTAL AXIS, THROUGH THE CENTER OF DATUM Z.

④NO TIE BAR PERMITTED FROM CARD EDGE TO LEADING EDGE OF PAD FOR PINS A1 AND PIN NUMBERS "F".

⑤CHAMFER EDGES MUST BE FREE OF CUTTING BURRS.

⑥FREQUENCY & LOCATION AT SUPPLIER DISCRETION. RIDGE MAY BE CONTINUOUS WITH NO BREAKS.

7.RoHS COMPATIBLE PRODUCT SPECIFICATIONS:

a - PLATING:

- "LF" MEANS THE PRODUCT IS LEAD-FREE, 2um MINIMUM MATTE TIN OVER 1.27um MINIMUM NICKEL UNDERPLATE.

b - MANUFACTURING PROCESS COMPATIBILITY:

- THE HOUSING WILL WITHSTAND EXPOSURE TO 260°C±5°C TEMPERATURE FOR 10 SECONDS IN RE-FLOW APPLICATION, SEE NOTE 8 FOR APPLICATION.

PRODUCT NUMBER CODE

10108777 -X X X X X X □ □

HOUSING COLOR OPTIONS

- 0-NATURAL
- 1-BLACK

PEGS OPTIONS

- 0-PLASTIC PEGS, DIM
- 1-METAL BOARD LOCKS
- 2-SINGLE PLASTIC PEGS

TERMINAL PLATING OPTIONS

- 0-50u" Ni UNDERPLATE  
30u" Au CONTACT AREA  
100u" TIN TAIL AREA ----- COMPATIBLE RoHS
- 1-50u" Ni UNDERPLATE  
15u" Au CONTACT AREA  
100u" TIN TAIL AREA ----- COMPATIBLE RoHS
- 2-50u" Ni UNDERPLATE  
GOLD FLASH CONTACT AREA  
100u" TIN TAIL AREA ----- COMPATIBLE RoHS
- 3-50u" Ni UNDERPLATE  
30u" Au CONTACT AREA  
100u" TIN/LEAD TAIL AREA ---INCOMPLIANT RoHS
- 4-50u" Ni UNDERPLATE  
15u" Au CONTACT AREA  
100u" TIN/LEAD TAIL AREA ---INCOMPLIANT RoHS
- 5-50u" Ni UNDERPLATE  
GOLD FLASH CONTACT AREA  
100u" TIN/LEAD TAIL AREA ---INCOMPLIANT RoHS

LEAD FREE OPTION

LEAVE BLANK FOR TERMINAL PLATING 3.4.5  
"LF" FOR TERMINAL PLATING OPTION 0,1,2

POS OPTIONS

- 0-36
- 1-64
- 2-98
- 3-164

TAIL LENGTH OPTIONS

	DIM "D"	PCB THICKNESS	DIM "G"
0	2.30 <sup>+0.25</sup> / <sub>-0.13</sub>	1.56±0.10	1.70±0.15
1	3.10 <sup>+0.25</sup> / <sub>-0.13</sub>	2.36±0.10	2.50±0.15
2	2.54±0.25	1.56±0.10	1.70±0.15
3	1.90±0.25	1.56±0.10	1.70±0.15
4	3.10 <sup>+0.25</sup> / <sub>-0.13</sub>	2.0±0.10	1.70±0.15

CONNECTOR	# POS REF.	N	DIM "A"	DIM "B"	DIM "C"	"E"
1 PORT	36	6	7.65	25.00	9.15	6.00
4 PORT	64	20	21.65	39.00	23.15	20.00
8 PORT	98	37	38.65	56.00	40.15	37.00
16 PORT	164	70	71.65	89.00	73.15	70.00

8.AN ADEQUATE PROCEDURE SET FORTH IN THE FOLLOWING ENSURE THAT THE PRODUCT RELIABILITY CAN BE ACHIEVED DURING AND AFTER PCB ASSEMBLY OPERATION.

8.1IF PARTIAL LOT ARE USED, THE REMAINING CONNECTORS MUST BE RESEALED AND PLACED IN SAFE STORAGE WITHIN SIX HOURS OF BAG OPENING.

8.2THE SAFE STORAGE CONDITION IS RECOMMENDED AT 25°C, 40%RH.

8.3NOT FOLLOWING THE PROCEDURE MAY CAUSE BLISTER DAMAGE DURING RE-FLOW PROCESS.

8.4IF BAKING IS REQUIRED, CONNECTOR SHALL BE BAKED FOR 4 HOURS AT 125°C.

8.5REFERENCE SPECIFICATION: IPC/JEDEC J-STD-033A.

PACKAGING OPTIONS

E-HARD TRAY WITH MYLAR FOR VACUUM PACKAGING (FOR 164P ONLY)

T-SOFT TRAY PACKAGING

C-SOFT TRAY PACKAGING WITH 10MM CAP

M-SOFT TRAY PACKAGING & MYLAR TAPE. SEE FIGURE 1

Y-HARD TRAY PACKAGING (FOR 36P,98P AND 164P ONLY)

Z-HARD TRAY PACKAGING WITH MYLAR (FOR 36P,98P AND 164P ONLY)

H-SMALLER HARD TRAY PACKAGING WITH 30MM CAP (323X136X17.7 FOR 164P ONLY)

△ Q-SMALLER HARD TRAY PACKAGING (323X136X17.7 FOR 164P ONLY)

R-TAPE & REEL PACKAGING WITHOUT MYLAR

(FOR 34, 64, 98P ONLY)

W-TAPE & REEL PACKAGING WITHOUT MYLAR

(FOR 98P ONLY), WITH 18.0MM CAVITY WIDTH

A-TAPE & REEL PACKAGING WITH MYLAR

(FOR 36, 64, 98P ONLY)

mat'l. code		-		surface		- ✓		tolerance		ASME_Y14.5		projection		product family		PCI_EXPRESS	
lfr		ecn no		dr		date		tolerances unless otherwise specified		angles		MM		title		PCI_EXPRESS_CARD_EDGE_GEN3	
								±2'		.02±0.30		scale N/A		TH_ASS'Y		5	
								.00±0.20						dwg no		sheet 6 of 7 size	
								.000±0.10						10108777		A4	
								dr		ZHENHUA_LIU		2016-03-30		Amphenol FCI		CUSTOMER Drawing	
								enfr		ZHENHUA_LIU		2016-03-30					
								chr		STONE_LI		2016-03-30					
								appd		PM_ZHENG		2016-03-30					
sheet index		revision		H													



POSTION OF MYLAR



POSTION OF CAP (10×10)



POSTION OF 30MM CAP(30X12)

mat'l. code		surface		tolerance		projection		product family	
-		-		ASME_Y14.5				PCI_EXPRESS	
lfr		ecn no		dr		date		title	
								PCI_EXPRESS_CARD_EDGE_GEN3	
				angles				TH_ASS'Y	
				±2'		scale N/A		dwg no	
				dr		ZHENHUA_LIU		sheet 7 of 7	
				enfr		ZHENHUA_LIU		size	
				chr		STONE_LI		A4	
				appd		PM_ZHENG		10108777	
								type	
								CUSTOMER Drawing	
sheet index		revision sheet		H					