

DO NOT SCALE FROM THIS PRINT

DESIGNED & DIMENSIONED IN MILLIMETERS [INCHES]

PES-XX-XX-X-RA-XX

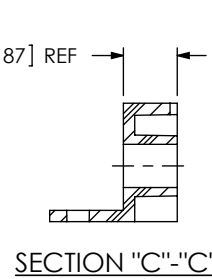
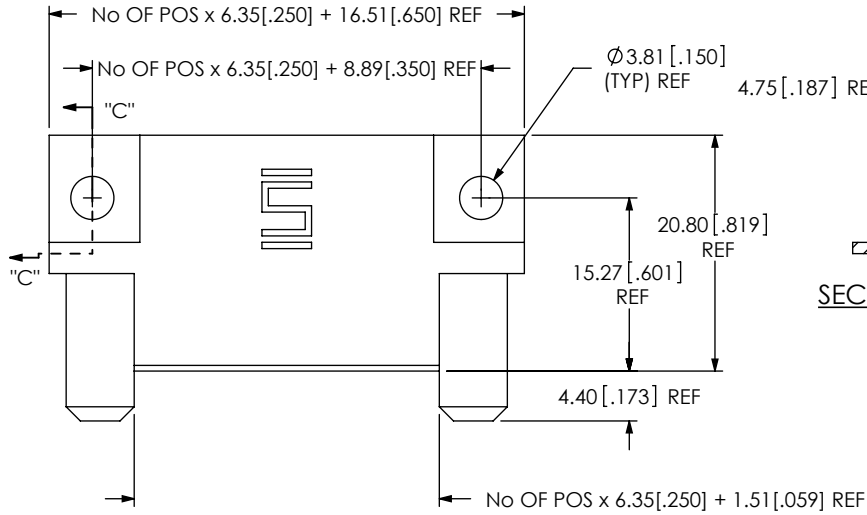

No OF POSITIONS
-02, -04, -06, -08

LEAD STYLE
-01: FOR 1.57 [.062] THICK PCB (USE SUB-C-205-01-X)
-02: FOR 3.18 [.125] THICK PCB (USE SUB-C-205-02-X)

OPTION *
-SD: SCREW DOWN (SEE FIG 1, SHT 1) (NOT AVAILABLE WITH -LC)
-LC: LOCKING CLIP (USE LC-11-TM) (SEE FIG 2, SHT 2) (NOT AVAILABLE WITH -SD)

RIGHT ANGLE
PLATING SPECIFICATION
-S: 30µ" SELECTIVE GOLD IN CONTACT AREA, MATTE TIN ON TAIL
-T: MATTE TIN CONTACT AND TAIL
-L: 10µ" LIGHT SELECTIVE GOLD ON CONTACT AREA, MATTE TIN ON TAIL

* BLANK ONLY FOR EXISTING CUSTOMERS

TABLE 1		
STYLE	"A"	SUB-C-205-XX-X
-01	2.35 [.093]	SUB-C-205-01-X
-02	3.95 [.156]	SUB-C-205-02-X

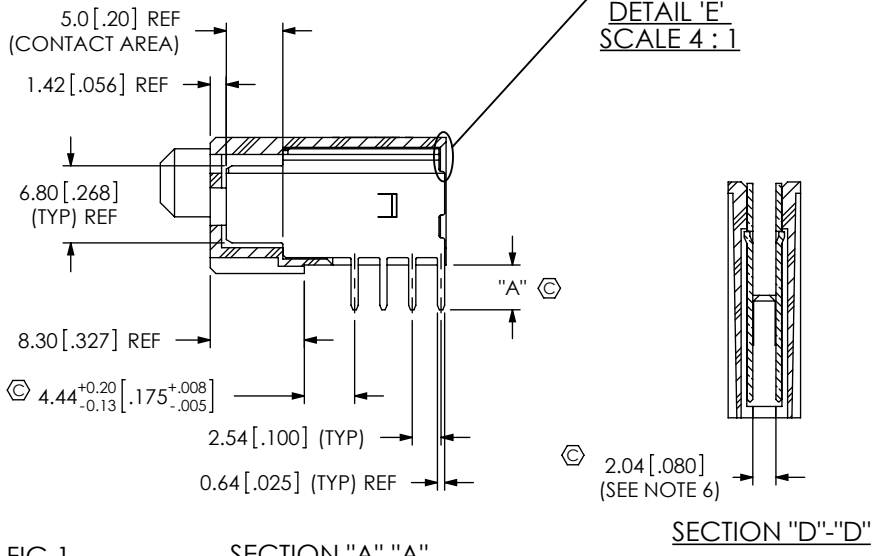
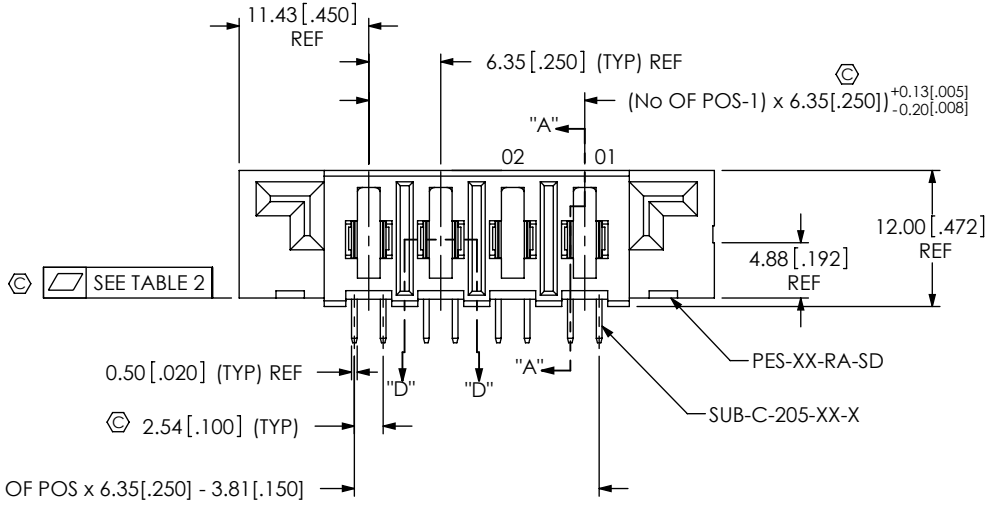
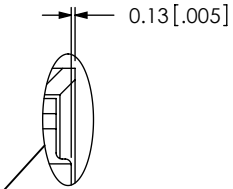
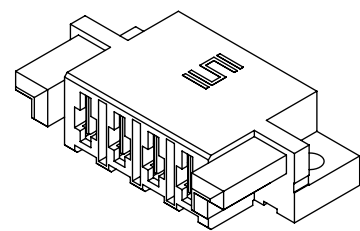

FIG 1 PES-04-02-X-RA-SD SHOWN

TABLE 2	
PART NUMBER	
PES-02-XX-X-RA-XX	0.15 MAX
PES-04-XX-X-RA-XX	0.15
PES-06-XX-X-RA-XX	0.20
PES-08-XX-X-RA-XX	0.20



NOTES:

- ① REPRESENTS A CRITICAL DIMENSION.
- COPLANARITY TO BE WITHIN 0.10 [.004].
- BURR ALLOWANCE: 0.038 [.0015] MAX.
- MINIMUM PUSHOUT FORCE: 4.45N [1.0 LB].
- PARTS TO BE PACKAGED IN TRAYS.A
- DIMENSION TO BE CHECKED ON THE INSIDE OF THE CONTACT.
- PARTS PLACED IN TRAY WITH PIN #1 FACING THE RIGHT SIDE, DUE TO PIN NUMBERING ORDER.

<p>UNLESS OTHERWISE SPECIFIED, DIMENSIONS ARE IN MILLIMETERS. TOLERANCES ARE:</p> <p>DECIMALS ANGLES</p> <p>.X: ±0.3 [.01] 2°</p> <p>.XX: ±0.13 [.005]</p> <p>.XXX: ±0.051 [.0020]</p>	<p>PROPRIETARY NOTE</p> <p>THIS DOCUMENT CONTAINS CONFIDENTIAL AND PROPRIETARY INFORMATION AND ALL DESIGN, MANUFACTURING, REPRODUCTION, USE, PATENT RIGHTS AND SALES RIGHTS ARE EXPRESSLY RESERVED BY SAMTEC, INC. THIS DOCUMENT SHALL NOT BE DISCLOSED, IN WHOLE OR PART, TO ANY UNAUTHORIZED PERSON OR ENTITY NOR REPRODUCED, TRANSFERRED OR INCORPORATED IN ANY OTHER PROJECT IN ANY MANNER WITHOUT THE EXPRESS WRITTEN CONSENT OF SAMTEC, INC.</p>	<p>520 PARK EAST BLVD, NEW ALBANY, IN 47150 PHONE: 812-944-6733 FAX: 812-948-5047 e-Mail: info@SAMTEC.com code: 55322</p>

FIG 2
 PES-04-02-X-RA-LC SHOWN
 (SAME AS FIG 1, UNLESS OTHERWISE STATED)

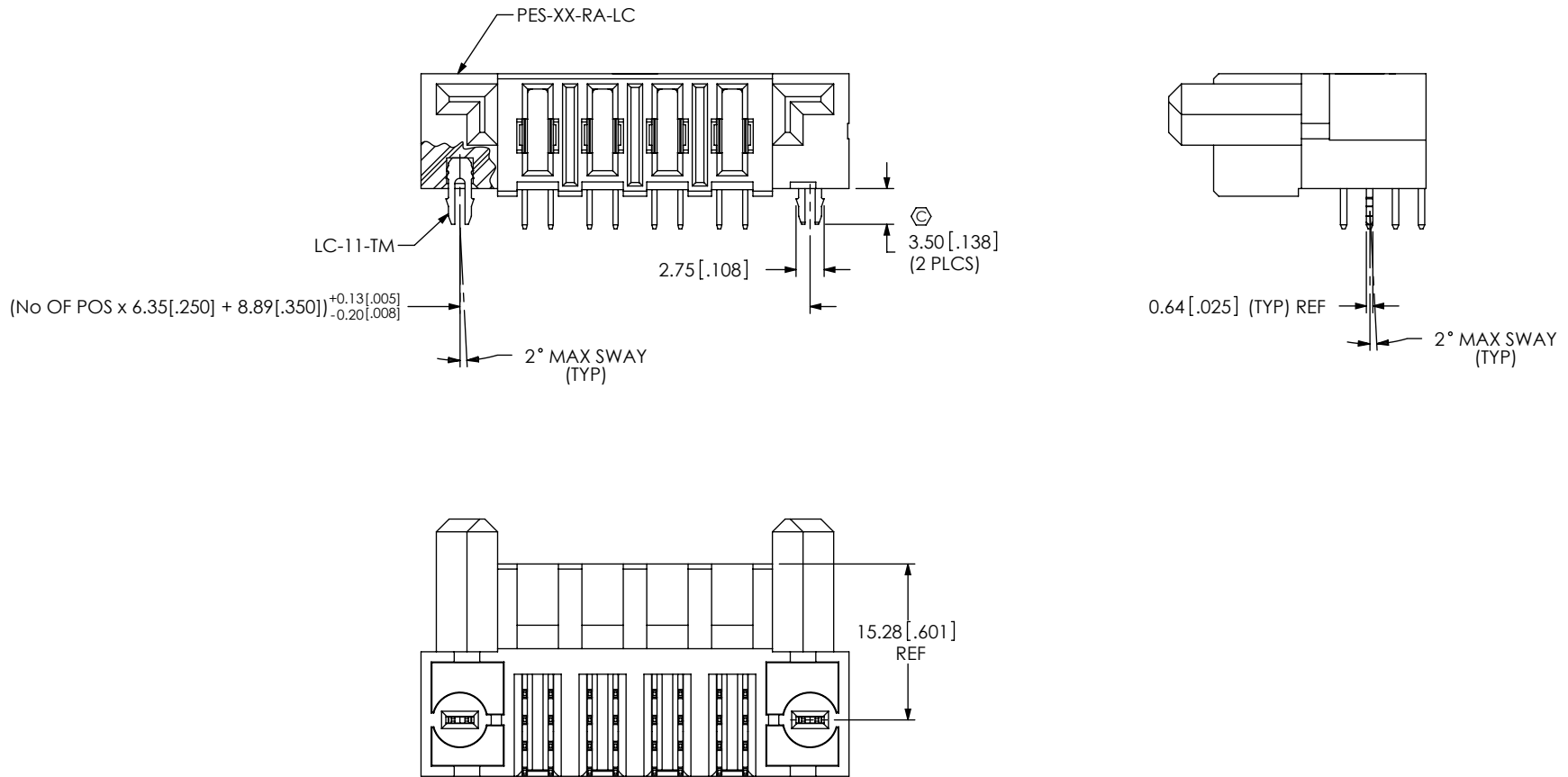

• PROPRIETARY NOTE •
 THIS DOCUMENT CONTAINS CONFIDENTIAL AND PROPRIETARY INFORMATION AND ALL DESIGN, MANUFACTURING, REPRODUCTION, USE, PATENT RIGHTS AND SALES RIGHTS ARE EXPRESSLY RESERVED BY SAMTEC, INC. THIS DOCUMENT SHALL NOT BE DISCLOSED, IN WHOLE OR PART, TO ANY UNAUTHORIZED PERSON OR ENTITY NOR REPRODUCED, TRANSFERRED OR INCORPORATED IN ANY OTHER PROJECT IN ANY MANNER WITHOUT THE EXPRESS WRITTEN CONSENT OF SAMTEC, INC.



520 PARK EAST BLVD, NEW ALBANY, IN 47150
 PHONE: 812-944-6733 FAX: 812-948-5047
 e-Mail: info@SAMTEC.com code: 55322

DO NOT SCALE DRAWING
 SHEET SCALE: 1.5:1

DESCRIPTION: RIGHT ANGLE POWER SOCKET
 DWG. NO. PES-XX-XX-X-RA-XX

BY: CHAD F 3/24/2005 SHEET 2 OF 2