

THIS COPY IS PROVIDED ON A RESTRICTED BASIS AND IS NOT TO BE USED IN ANY WAY DETRIMENTAL TO THE INTERESTS OF PANDUIT CORP.

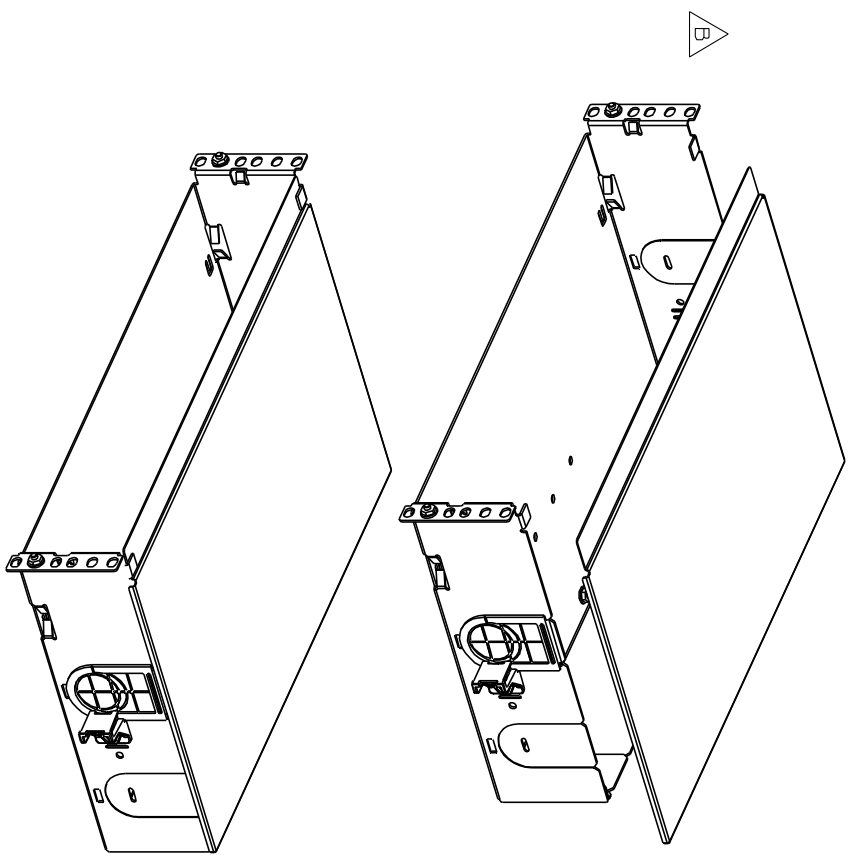

- NOTES:
1. SEE CURRENT CATALOG FOR COMPLETE LIST OF PARTS APPLICABLE FOR USE WITH THIS PART.
  2. TRAY PROVIDES A MEANS TO MANAGE AND ORGANIZE FIBER OPTIC CABLE WHEN USING PANDUIT MODULAR PATCH PANELS.
  3. MATERIAL:  
FIBER TRAY 16 GAGE(.060)(1.5) GALVANNEAL COVER 20 GAGE(.040)(1.0) GALVANNEAL.
  4. FIBER OPTIC TRAY MOUNTS BEHIND MODULAR PATCH PANELS WHICH ARE OPTIONAL.
  5. FIBER OPTIC TRAY MOUNTS ONTO EIA STANDARD 19" RACKS AND OCCUPIES ONE RACK SPACE.
  6. THIS PART INCLUDES A CABLE ROUTING ACCESSORY KIT.
  7. DIMENSIONS IN PARENTHESES ARE IN METRIC.

PANDUIT PART NO.	WEIGHT
FMT2	7.88 LB/EA 3582 g/EA

MODEL FILENAME V1005OAD\_FMT2-02.prt  
 CAD FILENAME/LAYERS V1005OAD\_DC\_00D.prt (1)

**PANDUIT**  
 CORP., TINLEY PARK, ILLINOIS  
 FIBER MOUNT TRAY (Fixed tray), 2RU  
 (FMT2)  
 CUSTOMER DRAWING

UNLESS OTHERWISE SPECIFIED,  
 DIMENSIONAL TOLERANCES ARE:  
 (.XX) ± .03 (.8 ANGLES) ±

UNLESS OTHERWISE SPECIFIED,  
 ALL DIMENSIONS ARE GIVEN  
 IN INCHES, THIRD ANGLE PROJECTION.

REV	DATE	BY	CHK	DESCRIPTION	ECN	R	CUST	SUP	OTH	DATE	CHK'D	MAT'L:	DRAWING NO.	DWG SIZE
3	5/10/07	DSI		C. REVISED PART NAME	10050-26								10050-26/A	A
2	4/15/02	RYB	RDC	B. REVISED EXPLODED VIEW	10050-26		RDC						10050-26/A	A
1	3/11/02	JDWE	RYB	A. CHANGED SHEET NUMBERS	10050-26	RYB	RDC						10050-26/A	A
R	2/26/02	RYB	RDC	RELEASED TO PRODUCTION	10050-26					2/26/02	RDC	SEE NOTES	10050-26/A	A
REV	DATE	BY	CHK	DESCRIPTION	ECN <td>R <td>CUST <td>SUP <td>OTH <td>DATE <td>CHK'D <td>MAT'L: <td>DRAWING NO. <td>DWG SIZE</td> </td></td></td></td></td></td></td></td>	R <td>CUST <td>SUP <td>OTH <td>DATE <td>CHK'D <td>MAT'L: <td>DRAWING NO. <td>DWG SIZE</td> </td></td></td></td></td></td></td>	CUST <td>SUP <td>OTH <td>DATE <td>CHK'D <td>MAT'L: <td>DRAWING NO. <td>DWG SIZE</td> </td></td></td></td></td></td>	SUP <td>OTH <td>DATE <td>CHK'D <td>MAT'L: <td>DRAWING NO. <td>DWG SIZE</td> </td></td></td></td></td>	OTH <td>DATE <td>CHK'D <td>MAT'L: <td>DRAWING NO. <td>DWG SIZE</td> </td></td></td></td>	DATE <td>CHK'D <td>MAT'L: <td>DRAWING NO. <td>DWG SIZE</td> </td></td></td>	CHK'D <td>MAT'L: <td>DRAWING NO. <td>DWG SIZE</td> </td></td>	MAT'L: <td>DRAWING NO. <td>DWG SIZE</td> </td>	DRAWING NO. <td>DWG SIZE</td>	DWG SIZE

THIS COPY IS PROVIDED ON A RESTRICTED BASIS AND IS NOT TO BE USED IN ANY WAY DETRIMENTAL TO THE INTERESTS OF PANDUIT CORP.

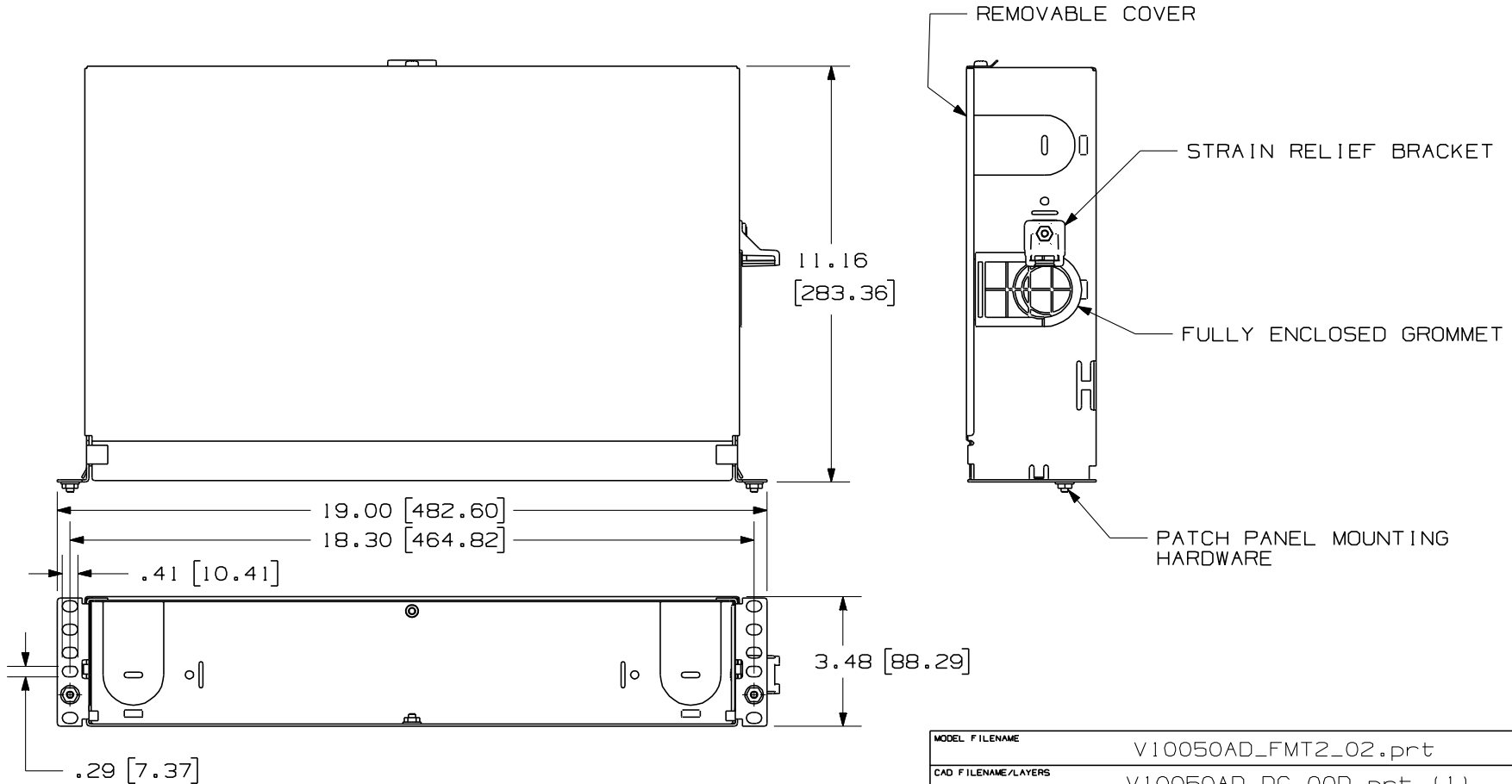

MODEL FILENAME V10050AD\_FMT2\_02.prt  
 CAD FILENAME/LAYERS V10050AD\_DC\_00D.prt (1)

**PANDUIT** CORP. TINLEY PARK, ILLINOIS  
 FIBER MOUNT TRAY (fixed tray), 2RU (FMT2)  
 CUSTOMER DRAWING

REV	DATE	BY	CHK	DESCRIPTION	ECN	R	CUST	SUP	OTH
3	5/10/07	DSI		SEE SHEET 1 OF 2 FOR REVISIONS	10050-26				
2	4/15/02	RYB	RDC	SEE SHEET 1 OF 2 FOR REVISIONS	10050-26		RDC		
1	3/11/02	JDWE	RYB	SEE SHEET 1 OF 2 FOR REVISIONS	10050-26		RYB	RDC	
R	2/26/02	RYB	RDC	SEE SHEET 1 OF 2 FOR REVISIONS	10050-26				

UNLESS OTHERWISE SPECIFIED, DIMENSIONAL TOLERANCES ARE: (.X) ± .03 (.XXX) ± .08 ANGLES ±		UNLESS OTHERWISE SPECIFIED, ALL DIMENSIONS ARE GIVEN IN INCHES, THIRD ANGLE PROJECTION.
SCALE	NONE	
DRAWING NO.	10050-26	DWG SIZE
SHEET 2 OF 2	A	A

DRAWN BY REY B  
 DATE 2/26/02  
 CHK'D RDC

MAT'L:  
 SEE NOTES