

THIS DRAWING IS UNPUBLISHED. RELEASED FOR PUBLICATION 20
 © COPYRIGHT 20 BY - ALL RIGHTS RESERVED.

LOC	DIST	REVISIONS			
P	LTR	DESCRIPTION	DATE	DWN	APVD
CM	00				
	G1	REVISED PER ECR-16-011506	27JUN2017	NK	CX

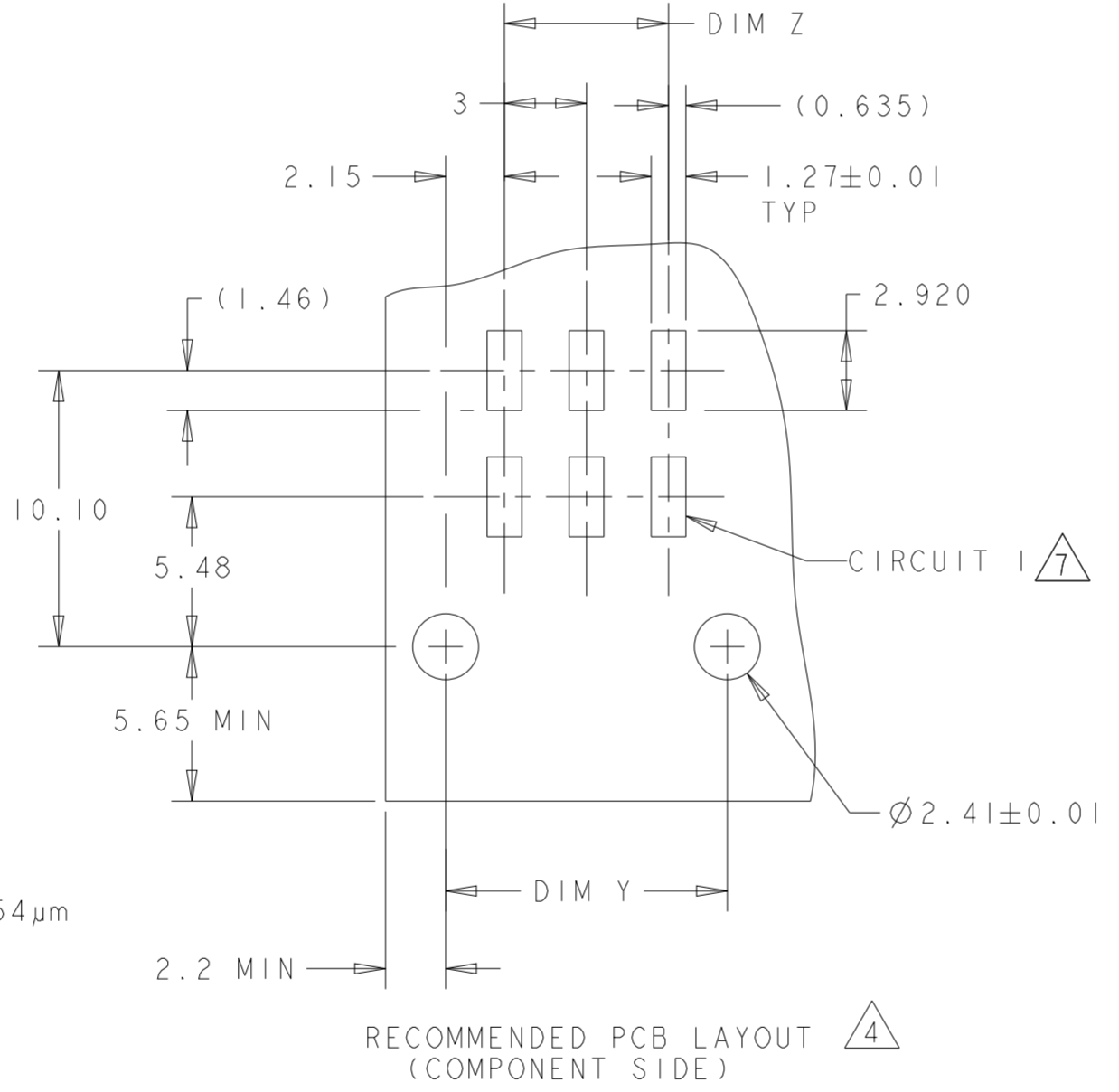
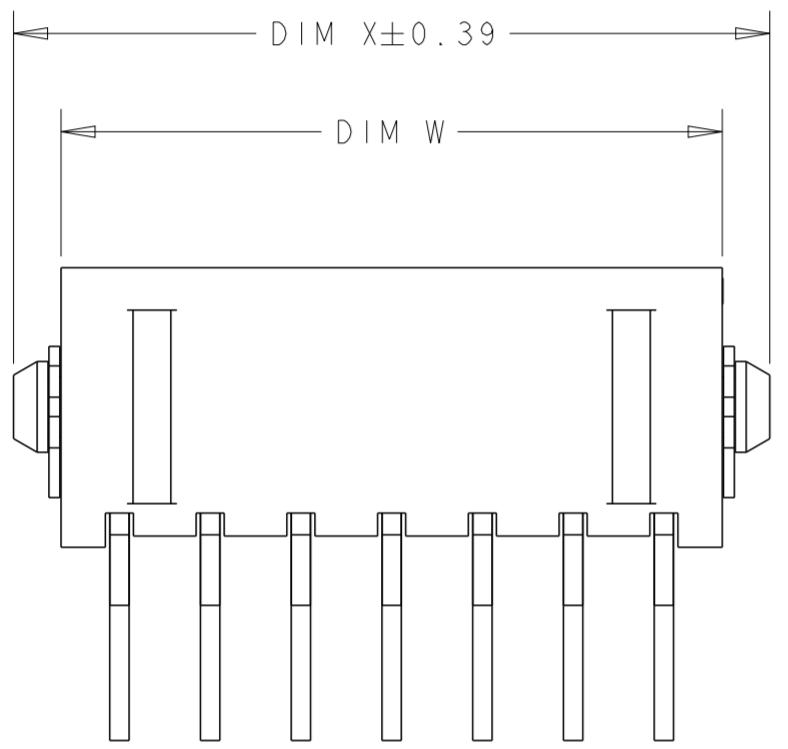
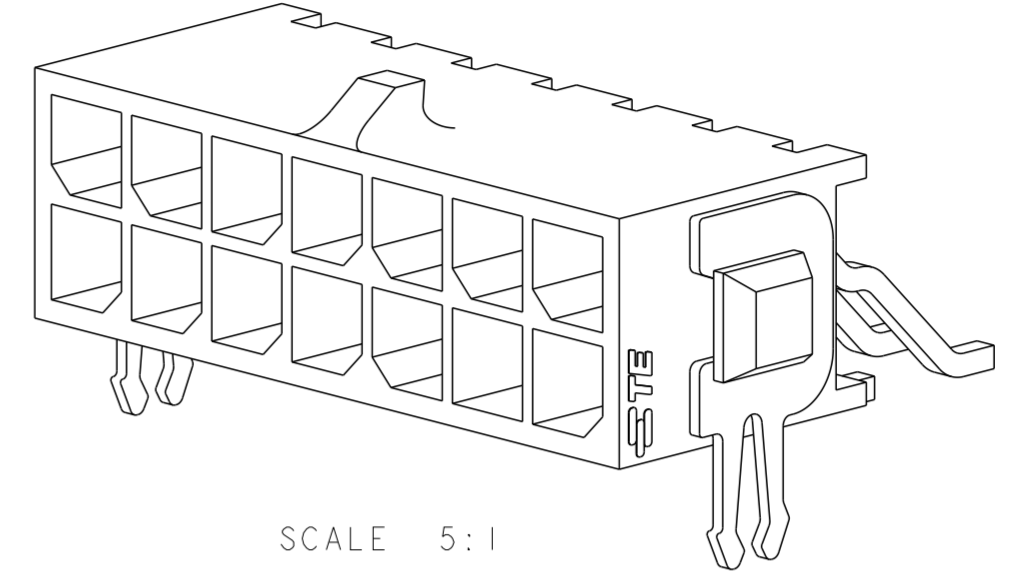
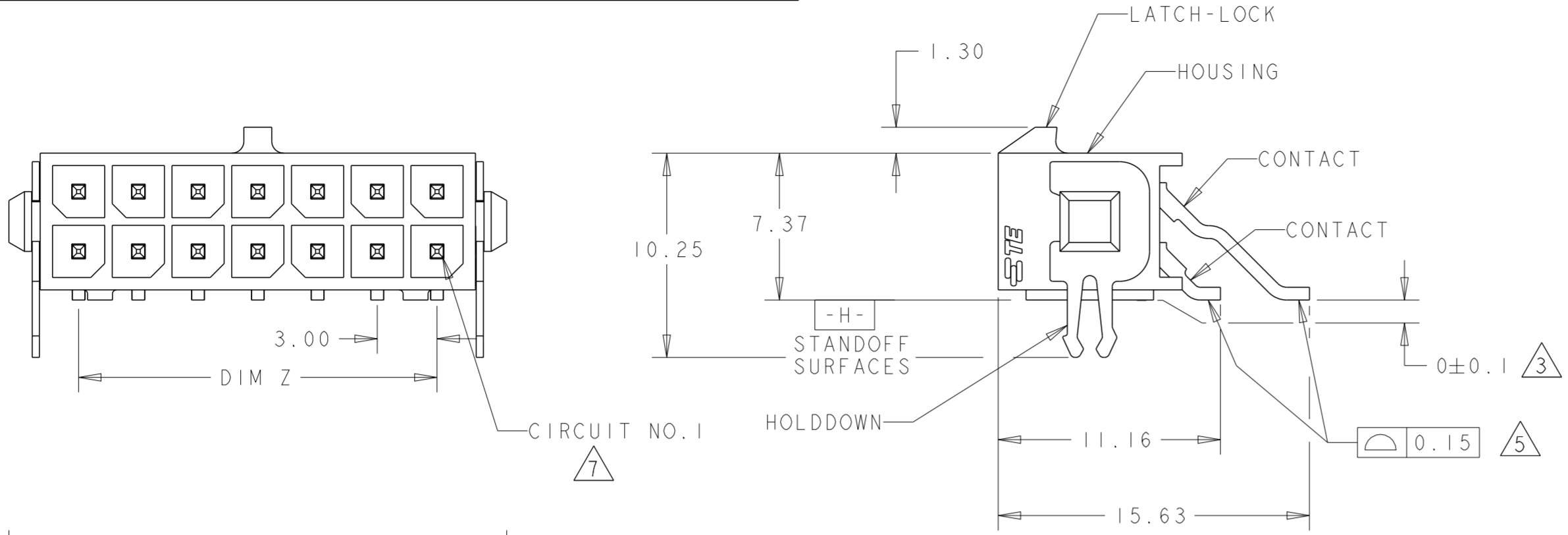

△6	36.86	37.30	33.00	40.00	24	5-794626-4
△6	33.86	34.30	30.00	37.00	22	5-794626-2
△6	30.86	31.30	27.00	34.00	20	5-794626-0
△6	27.86	28.30	24.00	31.00	18	4-794626-8
△6	24.86	25.30	21.00	28.00	16	4-794626-6
△6	21.86	22.30	18.00	25.00	14	4-794626-4
△6	18.86	19.30	15.00	22.00	12	4-794626-2
△6	15.86	16.30	12.00	19.00	10	4-794626-0
△6	12.86	13.30	9.00	16.00	8	3-794626-8
△6	9.86	10.30	6.00	13.00	6	3-794626-6
△6	6.86	7.30	3.00	10.00	4	3-794626-4
△6	3.86	4.30	-	7.00	2	3-794626-2
△2	36.86	37.30	33.00	40.00	24	2-794626-4
△2	33.86	34.30	30.00	37.00	22	2-794626-2
△2	30.86	31.30	27.00	34.00	20	2-794626-0
△2	27.86	28.30	24.00	31.00	18	+794626-8
△2	24.86	25.30	21.00	28.00	16	+794626-6
△2	21.86	22.30	18.00	25.00	14	+794626-4
△2	18.86	19.30	15.00	22.00	12	+794626-2
△2	15.86	16.30	12.00	19.00	10	+794626-0
△2	12.86	13.30	9.00	16.00	8	794626-8
△2	9.86	10.30	6.00	13.00	6	794626-6
△2	6.86	7.30	3.00	10.00	4	794626-4
△2	3.86	4.30	-	7.00	2	794626-2
FINISH	DIM W	DIM Y	DIM Z	DIM X	NO. OF POSN.	PART NUMBER

- 1 MATERIAL;
CONTACTS - BRASS.
HOUSING - UL 94V-0 RATED HIGH TEMP NYLON,
COLOR; BLACK.
HOLDDOWNS - PHOSPHOR BRONZE.
- 2 PLATING;
CONTACTS - 0.76µm MINIMUM GOLD OVER 2.54µm
MINIMUM NICKEL ON MATING AREA.
2.54µm TIN-LEAD MINIMUM OVER 2.54µm
NICKEL MINIMUM ON SOLDER TAILS.
HOLDDOWNS - 2.54µm TIN LEAD.
- 3 DIMENSION APPLIES TO SOLDER TAIL SURFACES
AND STANDOFF SURFACES.
- 4 RECOMMENDED PC BOARD THICKNESS OF 1.57.
- 5 ALL SOLDER TAILS.
- 6 PLATING;
CONTACTS - 0.76µm MINIMUM GOLD OVER 2.54µm
MINIMUM NICKEL ON MATING AREA.
2.54µm MATTE TIN MINIMUM OVER 2.54µm
NICKEL MINIMUM ON SOLDER TAILS.
HOLDDOWNS - 2.54µm MATTE TIN.
- 7 CIRCUIT NUMBER 1 IS LOCATED AT THE BOTTOM RIGHT
WITH THE LATCH-LOCK ON TOP LOOKING INTO THE CAVITIES

SUPERSEDED BY 5-794626-4	△2	36.86	37.30	33.00	40.00	24	2-794626-4
SUPERSEDED BY 5-794626-2	△2	33.86	34.30	30.00	37.00	22	2-794626-2
SUPERSEDED BY 5-794626-0	△2	30.86	31.30	27.00	34.00	20	2-794626-0
SUPERSEDED BY 4-794626-8	△2	27.86	28.30	24.00	31.00	18	+794626-8
SUPERSEDED BY 4-794626-6	△2	24.86	25.30	21.00	28.00	16	+794626-6
SUPERSEDED BY 4-794626-4	△2	21.86	22.30	18.00	25.00	14	+794626-4
SUPERSEDED BY 4-794626-2	△2	18.86	19.30	15.00	22.00	12	+794626-2
SUPERSEDED BY 4-794626-0	△2	15.86	16.30	12.00	19.00	10	+794626-0
SUPERSEDED BY 3-794626-8	△2	12.86	13.30	9.00	16.00	8	794626-8
SUPERSEDED BY 3-794626-6	△2	9.86	10.30	6.00	13.00	6	794626-6
SUPERSEDED BY 3-794626-4	△2	6.86	7.30	3.00	10.00	4	794626-4
SUPERSEDED BY 3-794626-2	△2	3.86	4.30	-	7.00	2	794626-2

THIS DRAWING IS A CONTROLLED DOCUMENT.

DWN: K. WHITAKER 19MAR2003
 CHK: C. JONES 19MAR2003
 APVD: C. JONES 19MAR2003

TE Connectivity

NAME: SURFACE MOUNT, RIGHT ANGLE, MECHANICAL
 HOLDDOWN, ASSEMBLY, 30 GOLD HEADER,
 DUAL ROW, MICRO MATE-N-LOK™

SIZE: A2 CAGE CODE: 0779 DRAWING NO: C-794626
 RESTRICTED TO: -

MATERIAL: SEE TABLE
 DIMENSIONS: mm
 TOLERANCES UNLESS OTHERWISE SPECIFIED:
 0 PLC ±
 1 PLC ±
 2 PLC ±0.13
 3 PLC ±
 4 PLC ±
 ANGLES ±
 FINISH

APPLICATION SPEC: -
 WEIGHT: -
 CUSTOMER DRAWING

SCALE: 4:1 SHEET 1 OF 1 REV: G1