

# LTM4603HV

## Synchronizable 28V, 6A

### Step-Down $\mu$ Module Regulator

## DESCRIPTION

Demonstration circuit DC1083A-B features the LTM<sup>®</sup>4603HV, the high efficiency, high density step-down  $\mu$ Module<sup>®</sup> regulator. The input voltage range is from 4.5V to 28V. The output voltage is jumper programmable from 0.6V to 5V. The rated load current is 6A, while derating is necessary for certain  $V_{IN}$ ,  $V_{OUT}$ , and thermal conditions. Applying an external clock signal to the PLLIN pin forces the  $\mu$ Module regulator to operate at the same frequency. The output ramp-up and ramp-down may be programmed

through the TRACK/SS pin. Margining function is provided for the user who wants to stress their system by varying supply voltages during testing. The LTM4603HV data sheet must be read in conjunction with this demo manual prior to working on or modifying demo circuit DC1083A-B.

**Design files for this circuit board are available at <http://www.linear.com/demo>**

LT, LT, LTC, LTM,  $\mu$ Module, Linear Technology and the Linear logo are registered trademarks of Linear Technology Corporation. All other trademarks are the property of their respective owners.

## PERFORMANCE SUMMARY ( $T_A = 25^\circ\text{C}$ )

PARAMETER	CONDITION	VALUE
Input Voltage Range		4.5V to 28V
Output Voltage $V_{OUT}$	Jumper Selectable (Open for 0.6V)	1.2V, 1.5V, 1.8V, 2.5V, 3.3V, 5V; $\pm 2\%$
Maximum Continuous Output Current	Derating is Necessary for Certain $V_{IN}$ , $V_{OUT}$ , and Thermal Conditions	6A <sub>DC</sub>
Default Operating Frequency		1MHz
External Clock Frequency Range	Refer to Data Sheet for Minimum $t_{ON}$ and $t_{OFF}$ Requirement	700kHz to 1.3MHz

## BOARD PHOTO

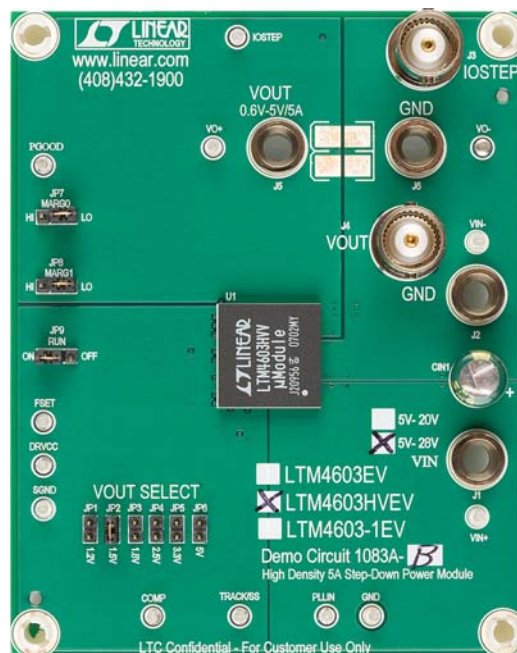

dc1083abf

# DEMO MANUAL DC1083A-B

## QUICK START PROCEDURE

Demonstration circuit 1083A-B is an easy way to evaluate the performance of the LTM4603HV. Please refer to Figure 1 for proper measurement equipment setup and follow the procedure below:

1. Place jumpers in the following positions for a typical 1.5V<sub>OUT</sub> application:

MARG0	MARG1	RUN	VOUT SELECT
LO	LO	ON	1.5V

2. With power off, preset the load to 0A and V<sub>IN</sub> supply to be less than 28V. Connect the input power supply, load and meters as shown in Figure 1.
3. Turn on the power at the input. The output voltage should be 1.5V ± 2%.
4. Once the proper output voltage is established, adjust the load within the operating range and observe the output voltage regulation, ripple voltage, efficiency and other parameters.

5. To measure input and output ripple, please refer to Figure 2 for proper setup.
6. For optional load transient test, apply adjustable pulse signal between IOSTEP CLK and GND pins. Pulse amplitude sets the current step. The pulse signal should have very small duty cycle (<5%) to limit the thermal stress on the transient load circuit. The output transient current can be monitored at BNC connector J3 (10mV/A), the output voltage can be monitor at BNC connector J4.
7. For margining function test, place jumper MARG0 and MARG1 in the configurations shown in the following table, measure the output voltage at J4.

MARG1	MARG0	ΔVOUT
LO	LO	0
LO	HI	5%
HI	LO	-5%
HI	HI	0

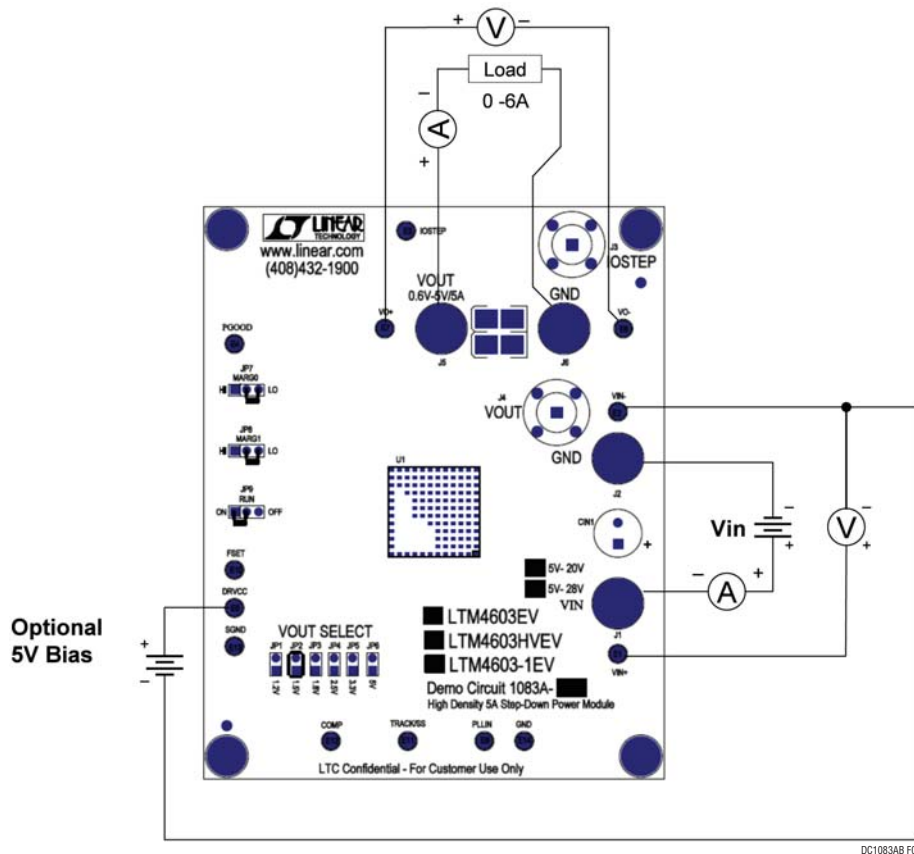
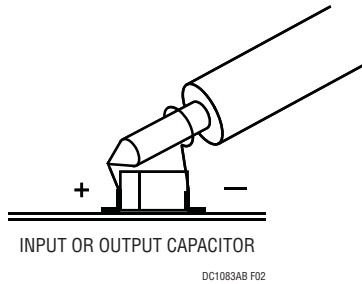
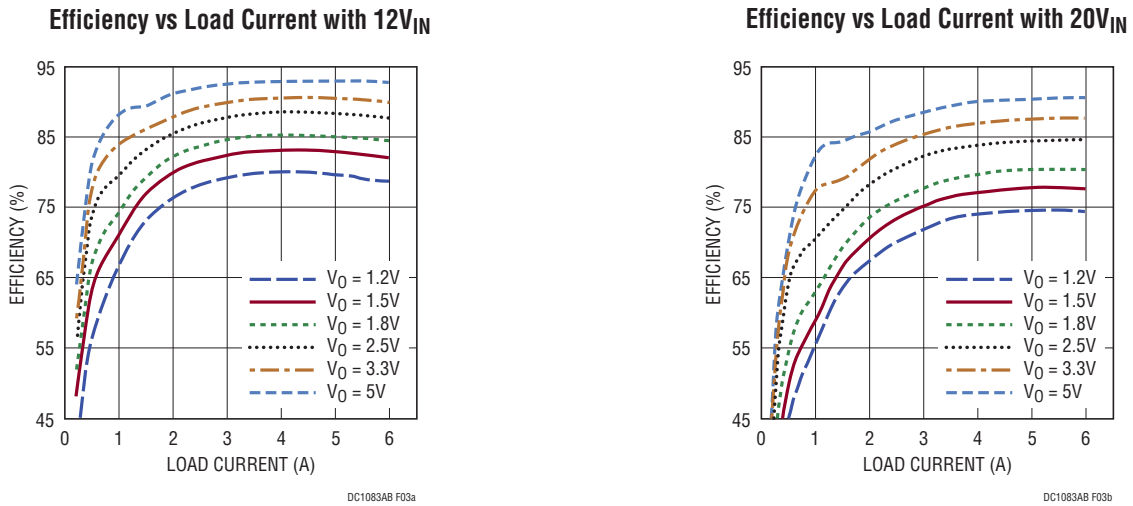

Figure 1. Test Setup of DC1083A-B (DRV<sub>CC</sub> Bias Supply is Optional)

**QUICK START PROCEDURE**



**Figure 2. Scope Probe Placements for Measuring Input or Output Ripple**



**Figure 3. Measured Supply Efficiency with Different  $V_{IN}$  and  $V_{OUT}$**

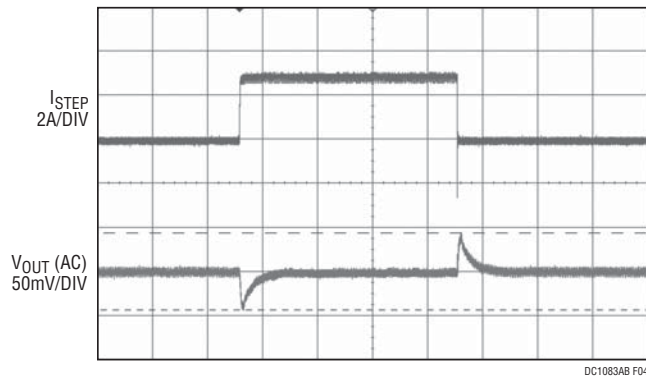

$V_{IN} = 12V$ ,  $V_{OUT} = 1.5V$   
 1.5A TO 4.5A LOAD STEP  
 $C_{OUT} = 1 \times 10\mu F$ , X5R, 1206 CERAMIC,  $1 \times 100\mu F$  X5R, 1812, CERAMIC

**Figure 4. Measured Load Transient Response (3A Step)**

# DEMO MANUAL DC1083A-B

## PARTS LIST

ITEM	QTY	REFERENCE	PART DESCRIPTION	MANUFACTURER/PART NUMBER
<b>Required Circuit Components</b>				
1	2	CIN2, CIN3	CAP, X7R 10 $\mu$ F 35V 20%	TAIYO YUDEN GMK316BJ106ML-T
2	1	COUT1	CAP, X5R 100 $\mu$ F 6.3V 20%	TAIYO YUDEN JMK432BJ107MU-T
3	1	COUT4	CAP, X5R 10 $\mu$ F 10V 10%	TAIYO YUDEN LMK316BJ106KL-T
4	1	C5	CAP, NPO 47pF 50V 10%	AVX 06035A470KAT1A
5	1	R14	RES, CHIP 51k 0.1W 5%	AAC CR16-513JM
6	1	R4	RES, CHIP 392k 0.1W 1%	AAC CR16-3923FM
7	2	R7, R23	RES, CHIP 0 $\Omega$ 1/16W 1A	AAC CJ06-000M
8	1	R16	RES, CHIP 40.2k 0.1W 1%	AAC CR16-4022FM
9	1	U1	IC, VOLTAGE REGULATOR	LINEAR TECHNOLOGY CORPORATION LTM4603HVEV
<b>Additional Demo Board Circuit Components</b>				
1	1	CIN1	CAP, ALUM 150 $\mu$ F 35V 10%	SANYO 35ME150WXV+TS (NOW SUNCON 35ME150WXV)
2	0	CIN4, CIN5	CAP, 1206 OPTIONAL	OPTIONAL
3	1	COUT2	CAP, 1812 OPTIONAL	OPTIONAL
4	0	COUT3	CAP, 1210 OPTIONAL	OPTIONAL
5	1	CSS	CAP, X7R 0.1 $\mu$ F 16V 20%	AVX 0603YC104MAT2A
6	2	C1, C2	CAP, X5R 1 $\mu$ F 10V 10%	TAIYO YUDEN LMK107BJ105KA
7	0	C3, C4, C6, C7	CAP, 0603 OPTIONAL	OPTIONAL
8	1	D1	ZENER DIODE, 5.1V	ON SEMICONDUCTOR MMBZ5231B
9	1	Q1	MOSFET, N-CHANNEL 30V	SILICONIX SUD50N03-10
10	2	R17, R1	RES, CHIP 10k 0.1W 5%	AAC CR16-103JM
11	1	R2	RES, LRC 0.010 0.25W 1%	IRC LRF1206-01-R010-F
12	1	R3	RES, CHIP 51k 0.1W 5%	AAC CR16-513JM
13	2	R8, R5	RES, CHIP 10 0.1W 5%	AAC CR16-100JM
14	0	R6, R9, R11, R12, R18	RES, 0603 OPTIONAL	OPTIONAL
15	1	R10	RES, CHIP 0 $\Omega$ 1/16W 1A	AAC CJ06-000M
16	1	R15	RES, CHIP 60.4k 0.1W 1%	AAC CR16-6042FM
17	1	R19	RES, CHIP 30.1k 0.06W 1%	AAC CR16-3012FM
18	1	R20	RES, CHIP 19.1k 0.1W 1%	AAC CR16-1912FM
19	1	R21	RES, CHIP 13.3k 0.1W 1%	AAC CR16-1332FM
20	1	R22	RES, CHIP 8.25k 0.1W 1%	AAC CR16-8251FM
<b>Hardware - for Demo Board Only</b>				
1	13	E1 TO E4, E6 TO E14,	TURRET, TESTPOINT	MILL MAX 2308-2
2	6	JP1 TO JP6	JUMPER, 2 PINS 2mm CTRS	SAMTEC TMM-102-02-L-S
3	3	JP7, JP8, JP9	HEADERS, 3 PINS 2mm CTRS	SAMTEC TMM-103-02-L-S
4	4	J1, J2, J5, J6	CONNECTOR, BANANA JACK	KEYSTONE 575-4
5	2	J3, J4	BNC CONNECTOR	CONNEX 112404
6	4	XJP2, XJP7, XJP8, XJP9	SHUNT, 2mm CTRS	SAMTEC 2SN-BK-G
7	4		STAND-OFF, NYLON, 0.50" Tall	KEYSTONE, 8833 (SNAP ON)

SCHEMATIC DIAGRAM

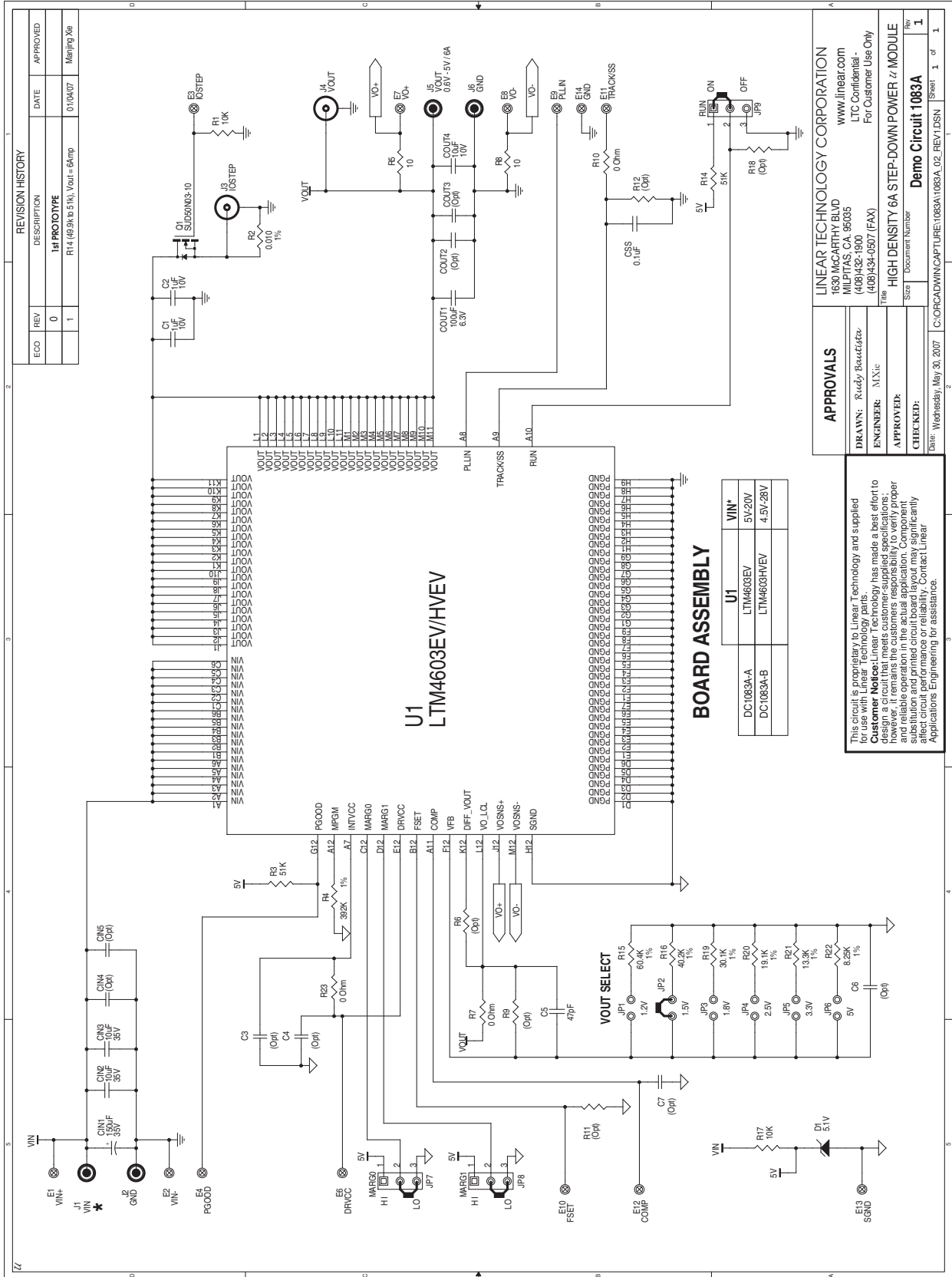

**REVISION HISTORY**

ECCO	REV	DESCRIPTION	DATE	APPROVED
	0	1st PROTOTYPE		
	1	R14 (49.9k to 51k), Vout1 = 64mp	01/04/07	Manning Xie

**APPROVALS**

DRAWN: Ready Scott@ltdc  
 ENGINEER: MX:c  
 APPROVED:  
 CHECKED:

LINEAR TECHNOLOGY CORPORATION  
 1630 MCCARTHY BLVD  
 MILPITAS, CA 95035  
 www.linear.com  
 LTC Confidential -  
 For Customer Use Only

Part: HIGH DENSITY 6A STEP-DOWN POWER 17 MODULE  
 Size: Document Number  
 Demo Circuit 1083A  
 Date: Wednesday, May 30, 2007  
 C:\ORCAD\WINCAPTURE\1083A\1083A\_02\_REV1.DSN

Sheet 1 of 1

This circuit is proprietary to Linear Technology and supplied for use with Linear Technology parts.  
**Customer Notice:** Linear Technology has made a best effort to design a circuit that meets customer-supplied specifications; however, we do not warrant proper operation in the actual application. Component substitution and printed circuit board layout may significantly affect circuit performance or reliability. Contact Linear Applications Engineering for assistance.



Information furnished by Linear Technology Corporation is believed to be accurate and reliable. However, no responsibility is assumed for its use. Linear Technology Corporation makes no representation that the interconnection of its circuits as described herein will not infringe on existing patent rights.

# DEMO MANUAL DC1083A-B

---

## DEMONSTRATION BOARD IMPORTANT NOTICE

Linear Technology Corporation (LTC) provides the enclosed product(s) under the following **AS IS** conditions:

This demonstration board (DEMO BOARD) kit being sold or provided by Linear Technology is intended for use for **ENGINEERING DEVELOPMENT OR EVALUATION PURPOSES ONLY** and is not provided by LTC for commercial use. As such, the DEMO BOARD herein may not be complete in terms of required design-, marketing-, and/or manufacturing-related protective considerations, including but not limited to product safety measures typically found in finished commercial goods. As a prototype, this product does not fall within the scope of the European Union directive on electromagnetic compatibility and therefore may or may not meet the technical requirements of the directive, or other regulations.

If this evaluation kit does not meet the specifications recited in the DEMO BOARD manual the kit may be returned within 30 days from the date of delivery for a full refund. **THE FOREGOING WARRANTY IS THE EXCLUSIVE WARRANTY MADE BY THE SELLER TO BUYER AND IS IN LIEU OF ALL OTHER WARRANTIES, EXPRESSED, IMPLIED, OR STATUTORY, INCLUDING ANY WARRANTY OF MERCHANTABILITY OR FITNESS FOR ANY PARTICULAR PURPOSE. EXCEPT TO THE EXTENT OF THIS INDEMNITY, NEITHER PARTY SHALL BE LIABLE TO THE OTHER FOR ANY INDIRECT, SPECIAL, INCIDENTAL, OR CONSEQUENTIAL DAMAGES.**

The user assumes all responsibility and liability for proper and safe handling of the goods. Further, the user releases LTC from all claims arising from the handling or use of the goods. Due to the open construction of the product, it is the user's responsibility to take any and all appropriate precautions with regard to electrostatic discharge. Also be aware that the products herein may not be regulatory compliant or agency certified (FCC, UL, CE, etc.).

No License is granted under any patent right or other intellectual property whatsoever. **LTC assumes no liability for applications assistance, customer product design, software performance, or infringement of patents or any other intellectual property rights of any kind.**

LTC currently services a variety of customers for products around the world, and therefore this transaction **is not exclusive**.

**Please read the DEMO BOARD manual prior to handling the product.** Persons handling this product must have electronics training and observe good laboratory practice standards. **Common sense is encouraged.**

This notice contains important safety information about temperatures and voltages. For further safety concerns, please contact a LTC application engineer.

Mailing Address:

Linear Technology  
1630 McCarthy Blvd.  
Milpitas, CA 95035

Copyright © 2004, Linear Technology Corporation