

max. 137 m³/h

DC centrifugal fans

Series RG 125 N 180 x 180 x 40 mm



- **Material:** Scroll housing: GRP¹⁾
Impeller: GRP¹⁾
Housing base: Sheet steel
 - **Direction of air flow:** Axial: Intake
Centrifugal: Exhaust
 - **Connection:** Via single wires AWG 22, TR 64
48 V model: Flat plug
6.3 x 0.8 mm for protective earth
 - **Highlights:** Backwards-curved impeller
 - **Mass:** 730 g
- **Possible special versions:** (See chapter DC fans - specials)
 - Speed signal
 - Go / No-go alarm
 - Alarm with limit speed
 - External temperature sensor
 - Internal temperature sensor
 - PWM control input
 - Analogue control input
 - Protection against moisture
 - Protection against salt fog
 - Type of protection: IP 54 / IP 68

1) Fibreglass-reinforced plastic

Nominal data	Air flow		Nominal voltage	Voltage range	Sound power level	Sinter sleeve bearings Ball bearings	Input power	Nominal speed	Temperature range	Service life L ₁₀ (40 °C) ebm-papst Standard	Service life L ₁₀ (T _{max}) ebm-papst Standard	Life expectancy L ₁₀ (IPC (40 °C) see page 17	Curve
	m ³ /h	CFM											
RG 125-19/12 NM	60,0	35,3	12	7...15	4,8	■	2,0	1 750	-30...+75	70 000 / 30 000		117 500	①
RG 125-19/12 N	87,5	51,5	12	7...15	5,8	■	5,2	2 550	-30...+75	62 500 / 27 500		105 000	②
RG 125-19/14 NM	60,0	35,3	24	12...28	4,8	■	2,0	1 750	-30...+75	70 000 / 30 000		117 500	①
RG 125-19/14 N	87,5	51,5	24	12...28	5,8	■	4,9	2 550	-30...+75	62 500 / 27 500		105 000	②
RG 125-19/18 N	87,5	51,5	48	36...56	5,8	■	4,8	2 550	-30...+75	62 500 / 27 500		105 000	②
RG 125-19/18 NH	137	80,6	48	36...56	7,0	■	19,0	4 000	-20...+70	55 000 / 27 500		92 500	③

Subject to alternations

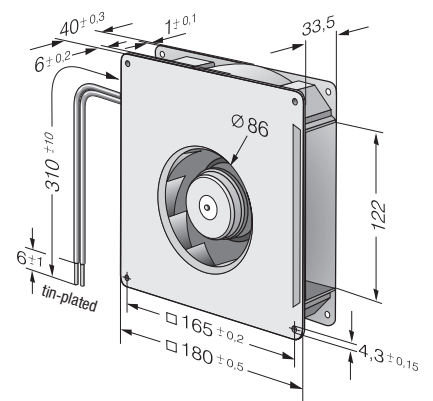
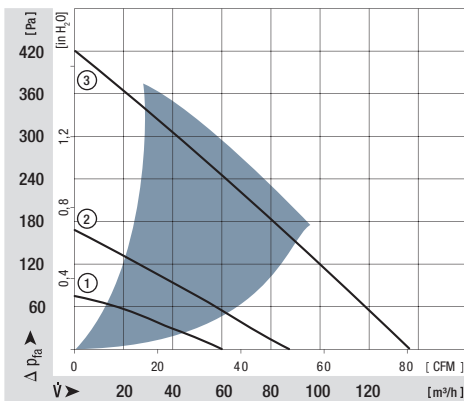

Speed signal /12

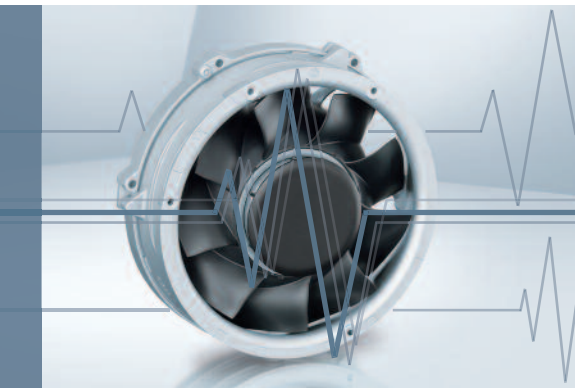

- Speed-proportional, square-wave signal for external monitoring of the fan motor speed
- 2, 3, or 6 pulses per revolution
- TTL-compatible
- Integrated pull-up resistor
- Connection via separate cable
- The sensor signal also serves as a major comparison variable for setting and maintaining the setpoint speed for interactive or controlled cooling with one or more interconnected fans.

Electrical hookup

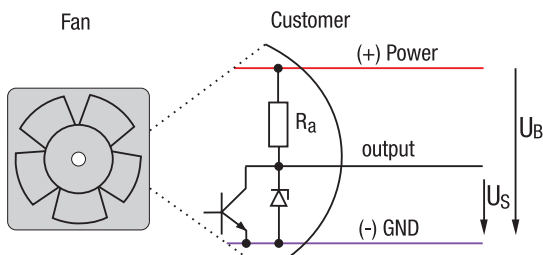

All voltages measured to ground.

Signal output voltage

Standard signal for all models (exceptions see below)

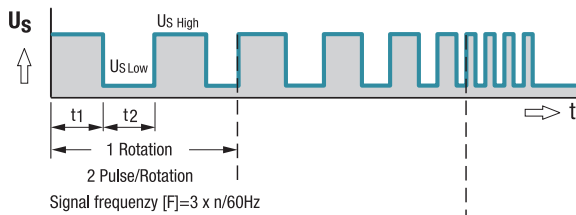

For multi options control input and 4100 NH7 and NH8

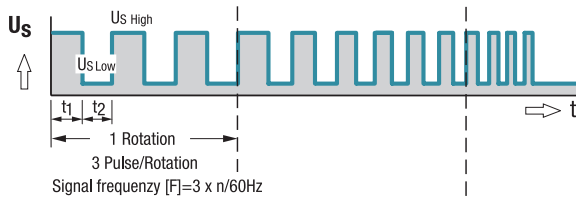

All TD Fans e.g. 6300 TD

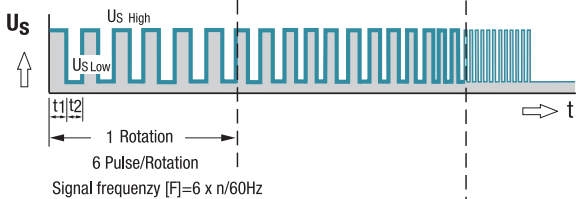

Fan speed

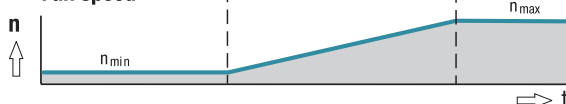

Signal data	Speed signal $U_{S\text{Low}}$	Condition: I_{sink}	Speed signal $U_{S\text{High}}$	Condition: I_{source}	Admissible sink current $I_{\text{sink max}}$	Fan description Basic type
Type	VDC	mA	VDC	mA	mA	Page
614 N/12 GM	≤ 0.4	1	2.5–5.5	1	1	39
618 N/12 N	≤ 0.4	1	2.5–5.5	1	1	39
8412 N/12 H	≤ 0.4	1	2.5–5.5	1	1	44
4412 F/12 GM	≤ 0.4	1	2.5–5.5	1	1	53
4418 F/12	≤ 0.4	1	2.5–5.5	1	1	53
4312 /12 M	≤ 0.4	1	2.5–5.5	1	1	56
4314 /12	≤ 0.4	1	2.5–5.5	1	1	56
4182 N/12 X	≤ 0.4	1	2.5–5.5	1	1	60

Subject to change

Note:

With these fan options, deviations in regard to temperature range, voltage range and power consumption are possible compared with standard fan data.

Available on request:

- Electrically isolated speed signal circuit
- Varying voltage potentials for power and logic circuit

Signal data		Speed signal U _S Low	Condition: I _{sink}	Speed signal U _S High	Condition: I _{source}	Admissible sink current I _{sink} max.	Fan description Basic type
Type	VDC	mA	VDC	mA	mA	Page	
7214 N/12	≤0.4	2	2.5–5.5	1	≤20	70	
6424/12 H	≤0.4	2	2.5–5.5	1	≤20	71	
DV 6424/12	≤0.4	2	4.5–5.25	2	≤12	73	
DV 6448/12	≤0.4	2	4.5–5.25	2	≤12	73	
RG 125-19/12 N/12	≤0.4	1	2.5–5.5	1	≤1	103	
RG 160-28/12 N/12	≤0.4	2	2.5–5.5	1	≤5	104	
RG 160-28/18 N/12	≤0.4	2	2.5–5.5	1	≤20	104	
RER 125-19/12 N/12	≤0.4	1	2.5–5.5	1	≤1	116	
RER 160-28/12 N/12	≤0.4	2	2.5–5.5	1	≤5	118	
RER 160-28/18 N/12	≤0.4	2	2.5–5.5	1	≤20	118	

Subject to change

Note:

Fans that come with these fan specials could have variations with respect to the temperature range, voltage range, and power consumption compared to standard fans without specials.