

used for:

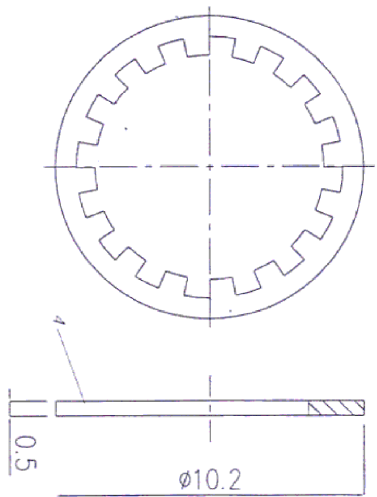
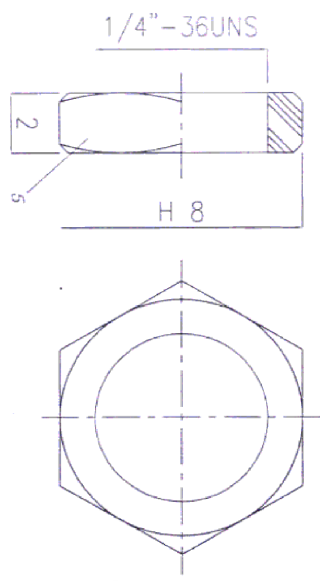
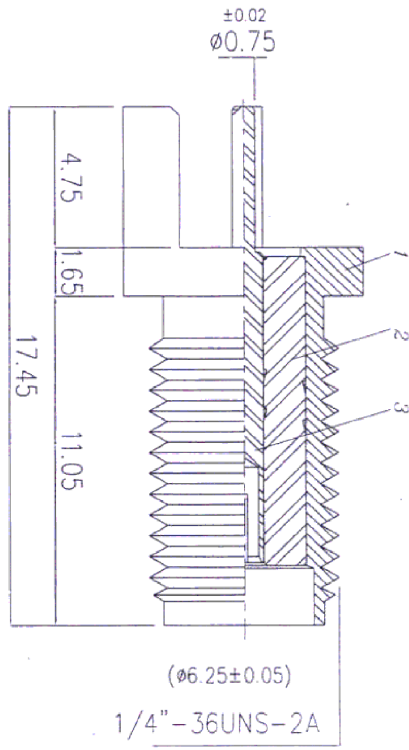
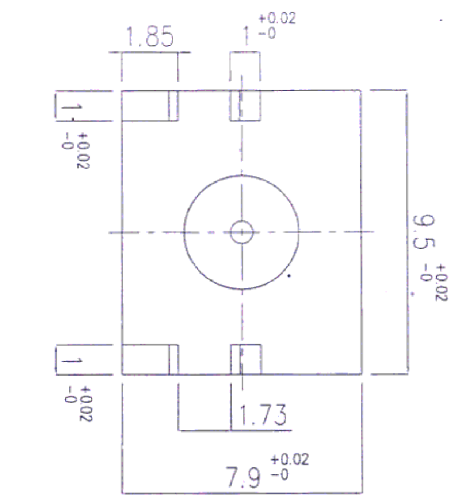

**RoHS Compliant**

NO	DESCRIPTION	QTY	MATERIAL	PLATING
1	Body	1	Brass	Gold 3u" - 5u" Min.
2	Dialectric	1	TEFLON	--
3	Center Pin	1	Beryllium Copper	Gold 5u" - 10u" Min.
4	Lock Washer	1	Brass	Gold 3u" - 5u" Min.
5	Nut	1	Brass	Gold 3u" - 5u" Min.

THIS DRAWING MAY NOT BE COPIED OR REPRODUCED IN ANY WAY, AND MAY NOT BE PASSED ON TO A THIRD PARTY WITHOUT WRITTEN PERMISSION. OWNERSHIP AND COPYRIGHT OF CONEC CORPORATION

DO NOT ALTER CAD DRAWING BY HAND

rev	description	date	name
1	origin		

<b>CONEC CORPORATION</b> Brampton, Ontario		tolerance unless otherwise specified Decimal: .xxx, .005, .01 Angles:		scale: material: SEE TABLE	
2006	date	name	title:	drawing no.:	DIN
drawn: Vincent Ke	Oct 26	name	SMA PCB JACK	AutoCAD 2005	A3
appd: N. Diamandas	Oct 26	norm	50 OHM		sheet
d-old					1/1

part no.: SMA-50SAG7762BRX

8 7 6 5 4 3 2 1