

High Efficiency 2-Channel LED Backlight Driver

Features

- Wide input range: 2.7V~5.5V
- High efficiency step-up 2-Channel LED driver
- 2-Ch current sinks, up to 8-LEDs per string
 - ▶ Up to 29.8mA/Ch in backlight mode
 - ▶ +/-0.6% current matching at 20.2mA
 - ▶ +/-1.5% current accuracy at 20.2mA
- I²C/PWM dual dimming control scheme
 - ▶ 11-bit I²C exponential or linear mapping with programmable transition ramp time
 - ▶ Wide range PWM dimming with programmable transition ramp time
 - 100Hz to 100kHz frequency
 - 0.2% to 100% duty cycle at 20kHz
- Programmable current sink turn on/off ramp time and shape
- Selectable boost converter switching frequency 1MHz or 500kHz with 20% shift up option
- Programmable input PWM hysteresis to minimize jitter at low PWM duty cycle
- Programmable OVP (25.9V/32V) and current limit (1.8A/2.6A)
- LED open/short protection
- Status reporting through I²C interface

Applications

- Smartphone/Tablet Backlight

Brief Description

KTD3133 is the ideal power solution for LED backlighting in medium to large size LCD panels. It is a highly integrated step-up DC-DC converter operating with an input voltage from 2.7V to 5.5V, accommodating 1-cell lithium ion batteries or 5V supply. It includes a high voltage power NMOS, as well as two current sinks, resulting in a simpler and smaller solution with fewer external components. High switching frequency allows the use of a smaller inductor and capacitor.

Each of the two regulated current sinks can regulate up to 29.8mA in backlight mode. With a maximum of 32V at the output of the step-up converter, each string can connect up to 8-LED in series for a 16-LED application.

KTD3133 is equipped with I²C interface for various controls. For additional flexibility, PWM dimming with wide range frequency and duty cycle is included to support Content Adaptive Brightness Control (CABC).

Various protection features are built into KTD3133, including cycle-by-cycle inductor current limit protection, output over-voltage protection, LED fault (open or short) protection and thermal shutdown protection.

KTD3133 is available in a RoHS compliant 12-ball 1.19mm x 1.64mm WLCSP or a 16-lead 3mm x 3mm x 0.75mm Thin-QFN package.

Typical Application

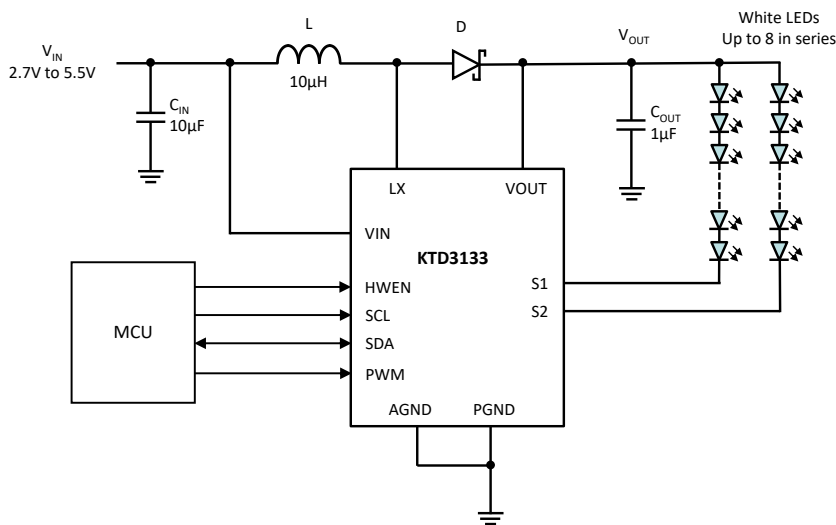



Ordering Information

Part Number	Marking ¹	Operating Temperature	Package
KTD3133EUS-TR	MAXXYZZZZ	-40°C to +85°C	WLCSP-12
KTD3133EFJ-TR	MAYYZ	-40°C to +85°C	TQFN33-16

1. XYZZZZ" / "XYZ" are the date code, assembly code and serial number / the date code and assembly code.

Kinetic Technologies cannot assume responsibility for use of any circuitry other than circuitry entirely embodied in a Kinetic Technologies product. No intellectual property or circuit patent licenses are implied. Kinetic Technologies reserves the right to change the circuitry and specifications without notice at any time.