

DUAL CHANNEL 3A 15V MONOLITHIC SYNCHRONOUS STEP-DOWN REGULATOR

DESCRIPTION

Demonstration circuit DC1347 is a dual output regulator consisting of two constant-frequency step-down converters, based on the LTC3633 monolithic dual channel synchronous buck regulator. The DC1347 has an input voltage range of 3.6V to 15V, with each regulator capable of delivering up to 3A of output current. The DC1347 can operate in either Burst Mode™ or forced continuous mode. In shutdown, the DC1347 can run off of less than 15 uA total. The DC1347 is a very efficient circuit: over

90% for either circuit. The LTC3633 comes in a 28 Pin QFN or leaded package, which each having an exposed pad on the bottom-side of the IC for better thermal performance. These features, plus a programmable operating frequency range from 500 kHz to 4 MHz (2 MHz switching frequency with the RT pin connected to INTVcc), make the DC1347 demo board an ideal circuit for use industrial or distributed power applications. **Gerber files for this circuit are available. Call the LTC Factory.**

QUICK START PROCEDURE

The DC1347 is easy to set up to evaluate the performance of the LTC3633. For a proper measurement equipment configuration, set up the circuit according to the diagram in Figure 1.

NOTE: When measuring the input or output voltage ripple, care must be taken to avoid a long ground lead on the oscilloscope probe. Measure the input or output voltage ripple by touching the probe tip directly across the Vin or Vout and GND terminals. See the proper scope probe technique in figure 2.

Please follow the procedure outlined below for proper operation.

1. Connect the input power supply to the Vin and GND terminals. Connect the loads between the Vout and GND terminals. Refer to figure 1 for the proper measurement equipment setup.

Before proceeding to operation, insert jumper shunts XJP1 and XJP2 into the OFF positions of headers JP1 and JP2, shunt XJP11 into the ON position (180°out-of-phase) of PHASE header JP11, shunts XJP3 and XJP4 into the soft-start (ss) positions of headers JP3 and

JP4, shunt XJP8 into the forced continuous mode (FCM) position of MODE header JP8, shunt XJP14 into the 1 MHz position of the frequency (FREQ) header JP14, shunts XJP12 and XJP13 into the external (EXT) compensation positions of headers JP12 and JP13, and shunt XJP6 into the Vout1 voltage options of choice of header JP6: 1.2V, 1.5V, or 1.8V, and a shunt into the Vout2 voltage option of choice: 2.5V (header JP15), 3.3V (header JP5), or 5V (header JP7).

2. Apply 5.5V at Vin. Measure both Vouts; they should read 0V. If desired, one can measure the shutdown supply current at this point. The supply current will be less than 100 uA in shutdown.

3. Turn on Vout1 and Vout2 by shifting shunts XJP1 and XJP2 from the OFF positions to the ON positions. Both output voltages should be within a tolerance of +/- 2%.

4. Vary the input voltage from 5.8V (the min. Vin is dependent on Vout) to 15V, and the load currents from 0 to 3A. Both output voltages should be within +/- 4% tolerance.

5. Set the load current of both outputs to 3A and the input voltage to 15V, and then measure each output ripple voltage (refer to figure 2 for proper measurement technique); they should each measure less than 30 mVAC. Also, observe the voltage waveform at either switch node (pins 23 & 24 for reg.1 and 13 & 14 for reg.2) of each regulator. The switching frequencies should be between 800 kHz and 1.2 MHz ($T = 1.25 \mu\text{s}$ and $0.833 \mu\text{s}$). To realize 2 MHz operation, change the shunt position on header JP14. In all cases, both switch node waveforms should be rectangular in shape, and 180° out-of-phase with each other. Change the shunt position on header JP11 to set the switch waveforms in phase with respect to each other. To operate the ckt.s in Burst Mode™, change the shunt in header JP8 to the Burst Mode™ position. When finished, insert shunts XJP1 and XJP2 to the OFF position(s) and disconnect the power.

Warning - If the power for the demo board is carried in long leads, the input voltage at the part could “ring”, which could affect the operation of the circuit or even exceed the maximum voltage rating of the IC. To eliminate the ringing, a small tantalum capacitor (for instance, AVX part # TPSY226M035R0200) is inserted on the pads between the input power and return terminals on the bottom of the demo board. The (greater) ESR of the tantalum will dampen the (possible) ringing voltage due to the use of long input leads. On a normal, typical PCB, with short traces, this capacitor is not needed.

Table 1. Performance Summary ($T_A = 25^\circ\text{C}$)

PARAMETER	CONDITIONS	VALUE
Minimum Input Voltage		3.6V
Maximum Input Voltage		15V
Run	RUN Pin = GND	Shutdown
	RUN Pin = V_{IN}	Operating
Output Voltage V_{OUT1}	$V_{IN} = 3.6\text{V to }15\text{V}$, $I_{OUT1} = 0\text{A to }3\text{A}$	$1.2\text{V} \pm 4\%$ (1.152V – 1.248V)
		$1.5\text{V} \pm 4\%$ (1.44V - 1.56V)
		$1.8\text{V} \pm 4\%$ (1.728V – 1.872V)
Typical Output Ripple V_{OUT1}	$V_{IN} = 12\text{V}$, $I_{OUT1} = 3\text{A}$ (20 MHz BW)	< 30mV _{P-P}
Output Regulation V_{OUT1}	Line	$\pm 1\%$
	Load	$\pm 1\%$
Output Voltage V_{OUT2}	$V_{IN} = 3.6\text{V to }15\text{V}$, $I_{OUT2} = 0\text{A to }3\text{A}$	$2.5\text{V} \pm 4\%$ (2.4V – 2.6V)
		$3.3\text{V} \pm 4\%$ (3.168V – 3.432V)
		$5\text{V} \pm 4\%$ (4.8V – 5.2V)
Typical Output Ripple V_{OUT2}	$V_{IN} = 12\text{V}$, $I_{OUT2} = 3\text{A}$ (20 MHz BW)	< 30mV _{P-P}
Output Regulation V_{OUT2}	Line	$\pm 1\%$
	Load	$\pm 1\%$
Nominal Switching Frequencies	RT Pin connected to 324k	1 MHz
	RT Pin = INTV _{CC}	2 MHz
Burst Mode™ Operation	Channel 1: $V_{in} = 12\text{V}$, $V_{out1} = 1.8\text{V}$, $F_{sw} = 1\text{ MHz}$	$I_{out1} = 1.3\text{A}$
	Channel 2: $V_{in} = 12\text{V}$, $V_{out2} = 3.3\text{V}$, $F_{sw} = 1\text{ MHz}$	$I_{out2} = 850\text{ mA}$
	Channel 1: $V_{in} = 12\text{V}$, $V_{out1} = 1.8\text{V}$, $F_{sw} = 2\text{ MHz}$	$I_{out1} = 800\text{ mA}$
	Channel 2: $V_{in} = 12\text{V}$, $V_{out2} = 3.3\text{V}$, $F_{sw} = 2\text{ MHz}$	$I_{out2} = 500\text{ mA}$
Phase	Phase Pin = INTV _{CC}	Out-of-Phase
	Phase Pin = GND	In Phase
INTV _{CC}		3.3V
V2P5		2.5V

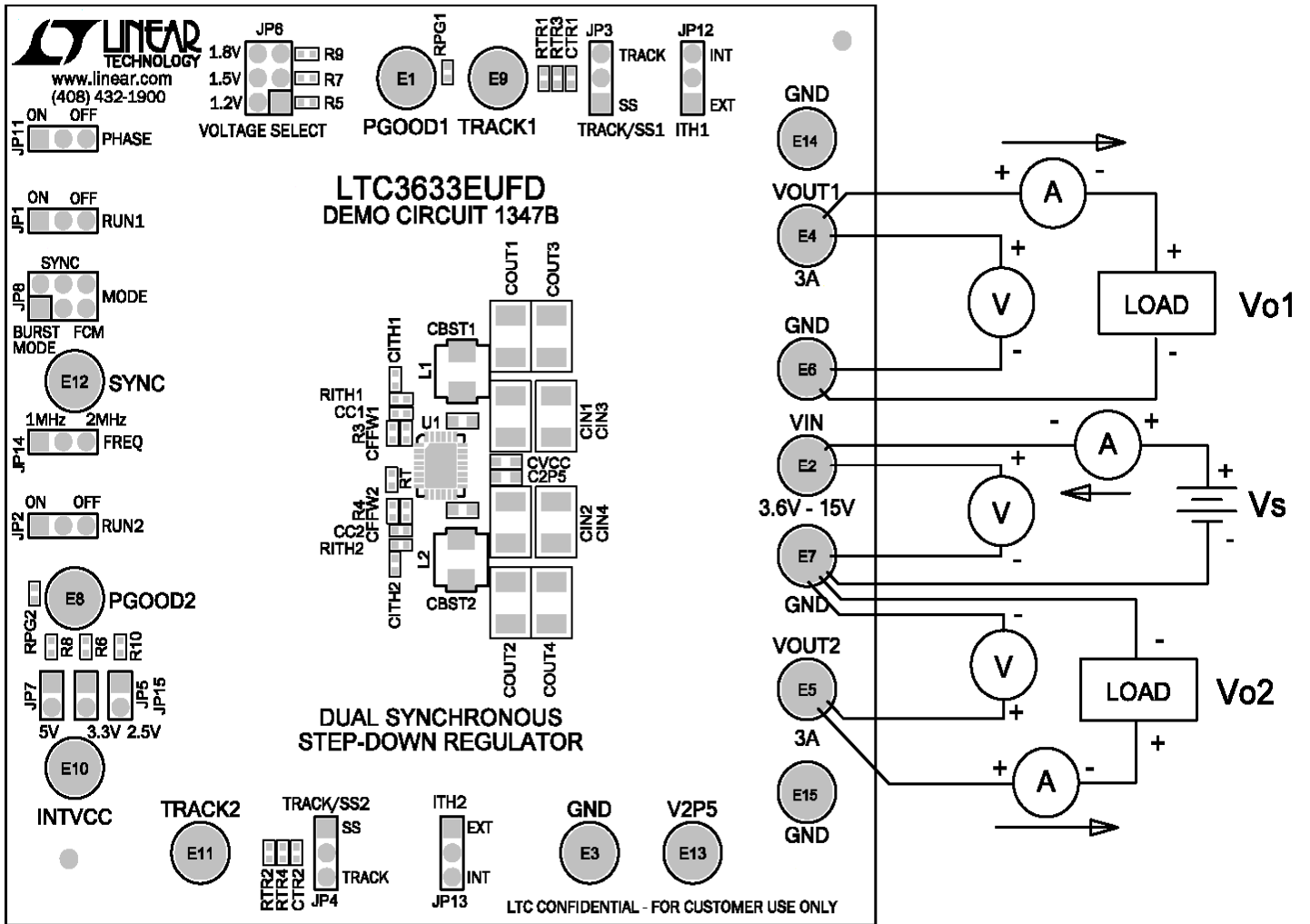

Figure 1. Proper Measurement Equipment Setup

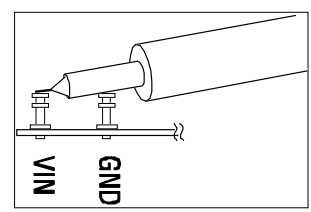

Figure 2. Measuring Input or Output Ripple

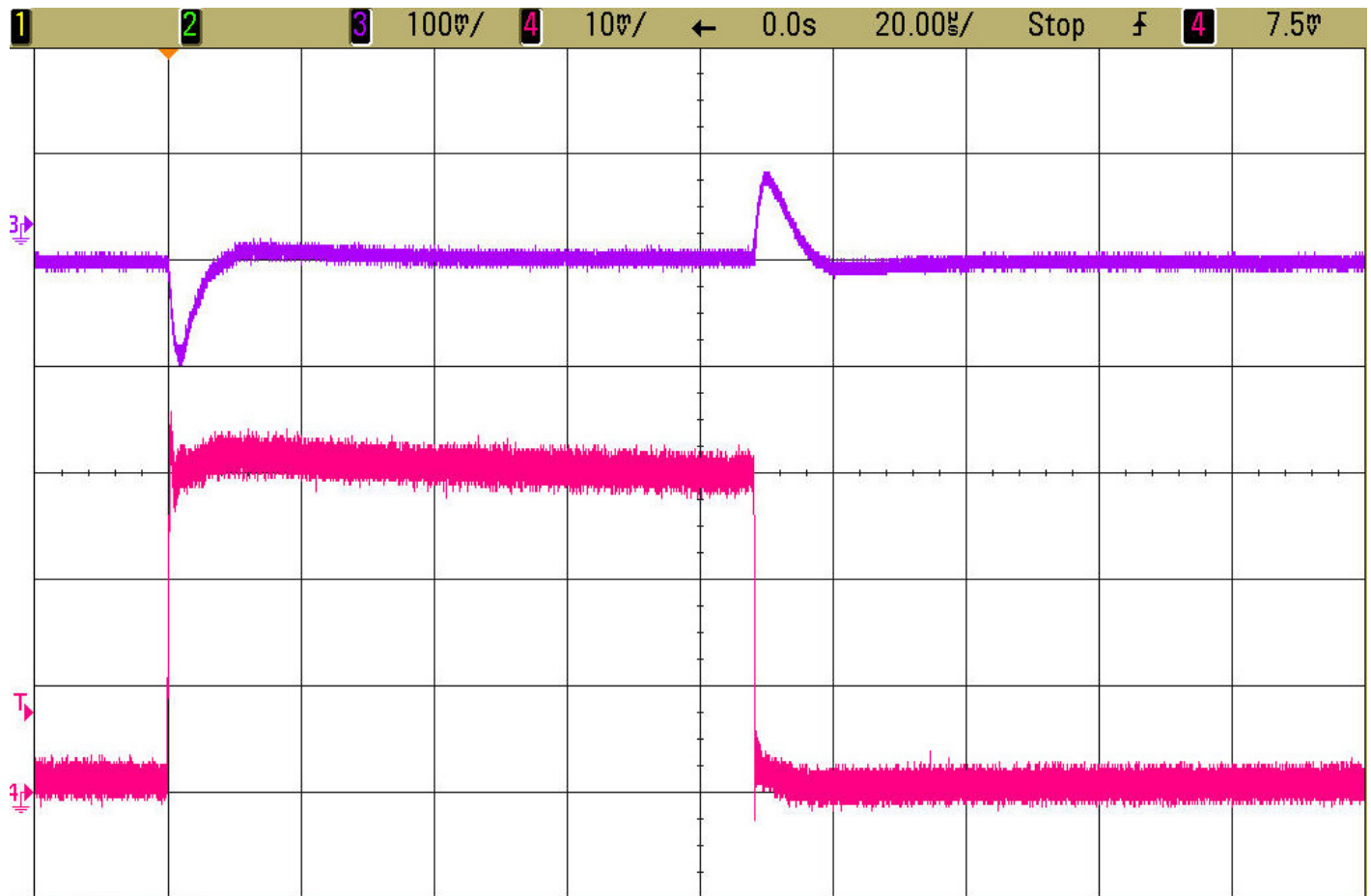

Figure 3. V_{OUT1} Load Step Response

$V_{IN} = 12V$, $V_{OUT1} = 1.8V$, 3A Load Step (0.1A \leftrightarrow 3A)

Forced Continuous Mode $F_{sw} = 2\text{ MHz}$
External Compensation: $R_{ith} = 13k$, $C_{ith} = 220\text{ pF}$
Trace 3: Output Voltage (100mV/div AC)
Trace 4: Output Current (1A/div)

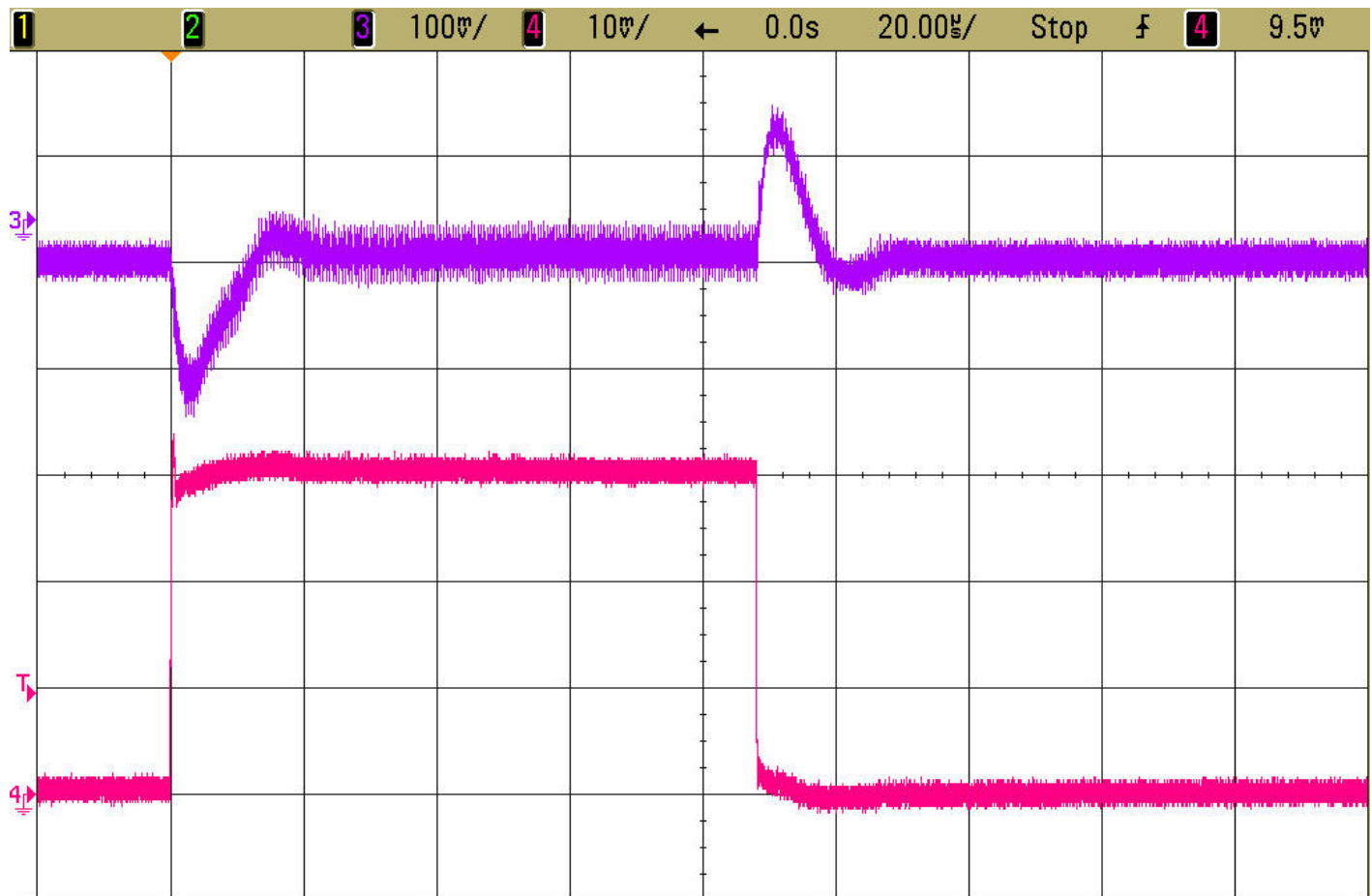

Figure 4. V_{OUT2} Load Step Response

$V_{IN} = 12V$, $V_{OUT2} = 3.3V$, 3A Load Step (0.1A \leftrightarrow 3A)

Forced Continuous Mode $F_{SW} = 2\text{ MHz}$
 External Compensation: $R_{ith} = 13k$, $C_{ith} = 220\text{ pF}$
 Trace 3: Output Voltage (100mV/div AC)
 Trace 4: Output Current (1A/div)

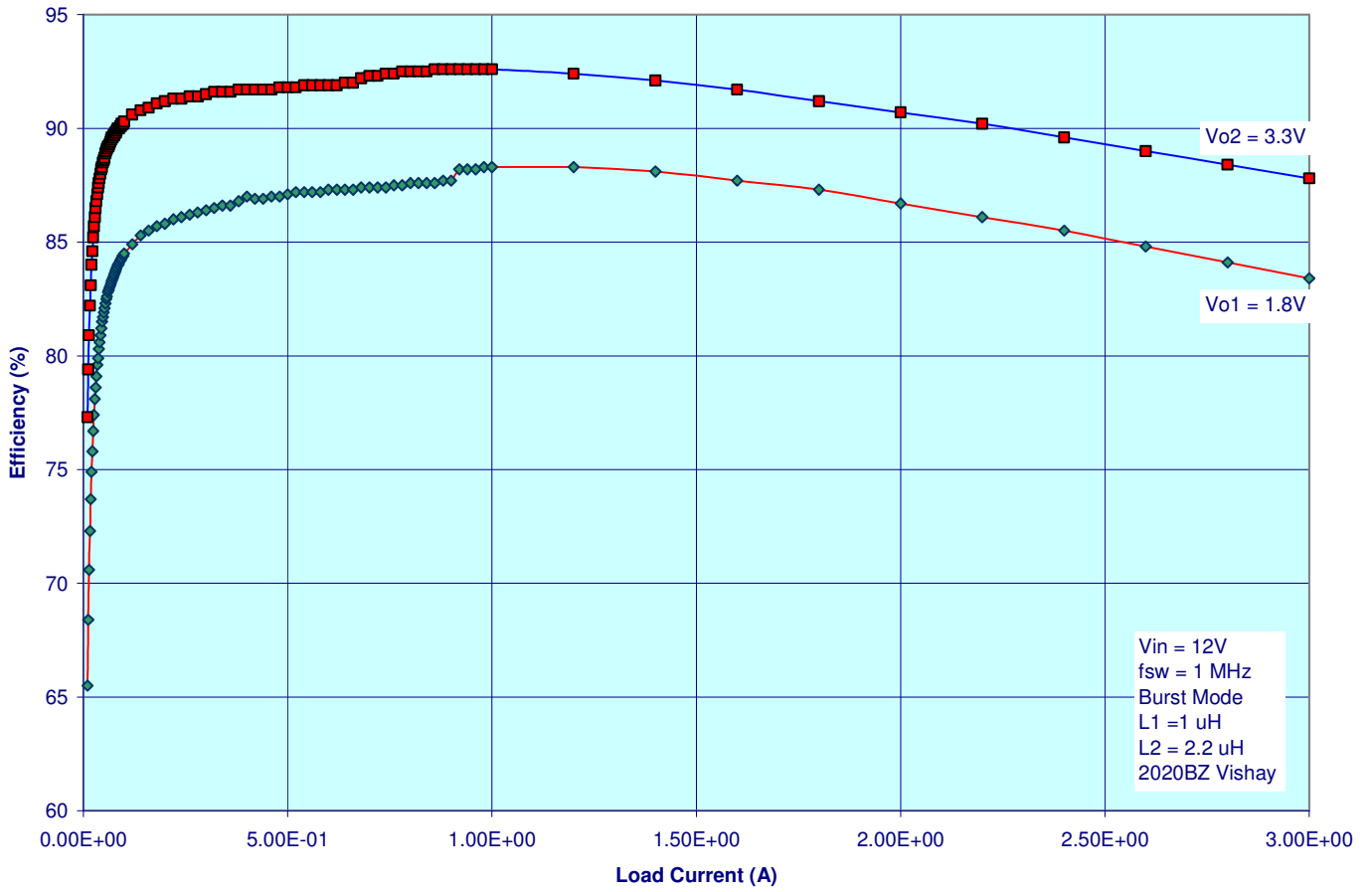
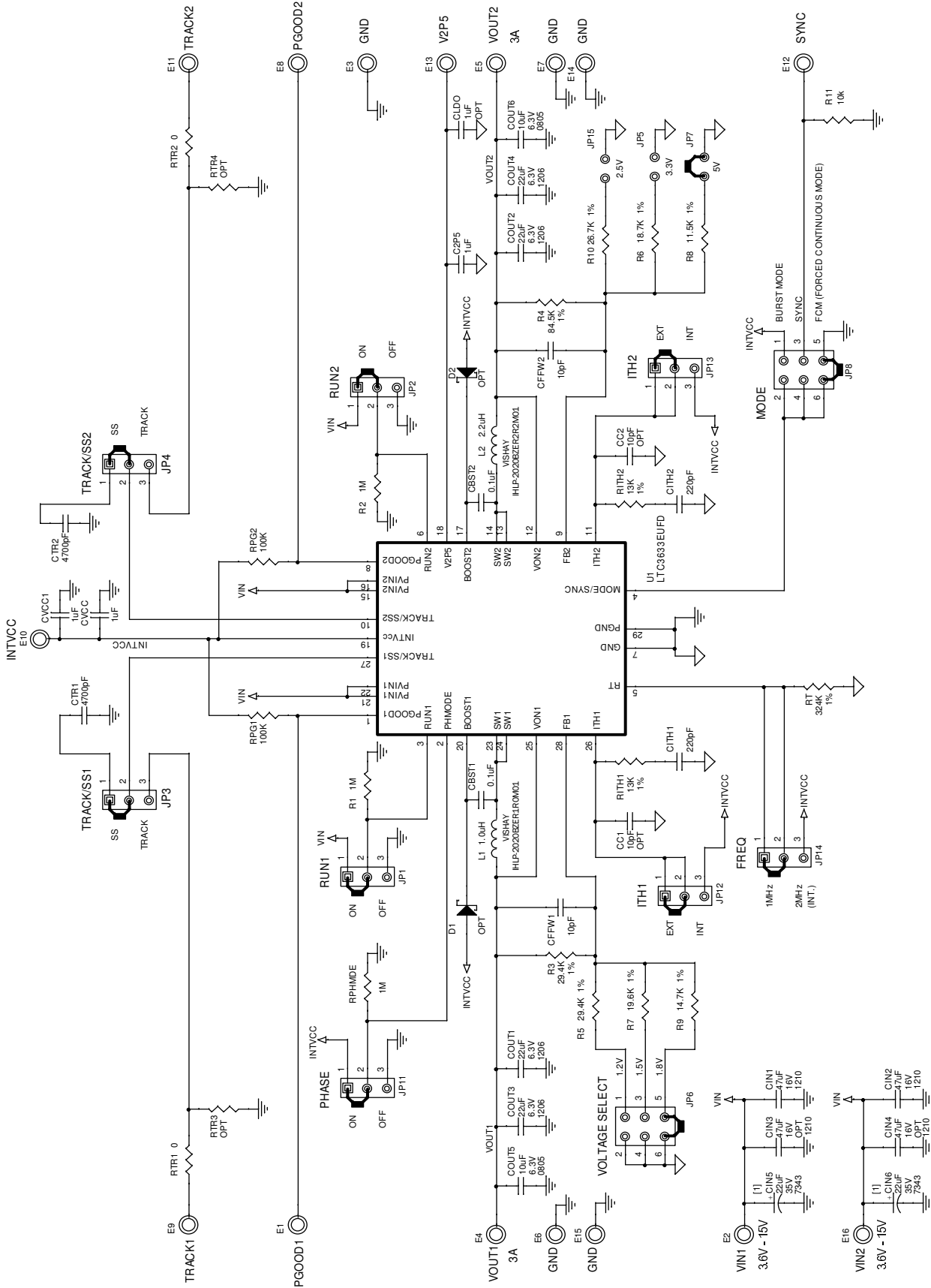

Figure 5. LTC3633 DC1347 Efficiency



NOTES: UNLESS OTHERWISE SPECIFIED,
 [1] CIN5 AND CIN6 ARE INSERTED ON DC1347 TO DAMPEN THE (POSSIBLE) RINGING VOLTAGE DUE TO THE USE OF LONG INPUT LEADS. ON A NORMAL, TYPICAL PCB, WITH SHORT TRACES, CIN5 AND CIN6 ARE NOT NEEDED.
 2. ALL RESISTOR AND CAPACITOR CASE SIZE ARE 0402.