

THIS DOCUMENT IS THE PROPERTY OF KEYSTONE ELECTRONICS CORP. AND SHALL NOT BE REPRODUCED, DISTRIBUTED OR USED AS A BASIS FOR MANUFACTURE WITHOUT PRIOR WRITTEN PERMISSION FROM KEYSTONE ELECTRONICS CORP.

REQUIRED SPACING FOR 'AAA' CLIP

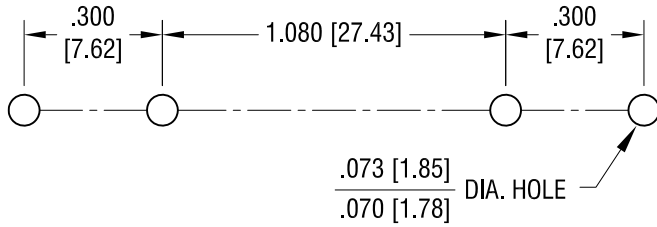

ACTUAL SIZE

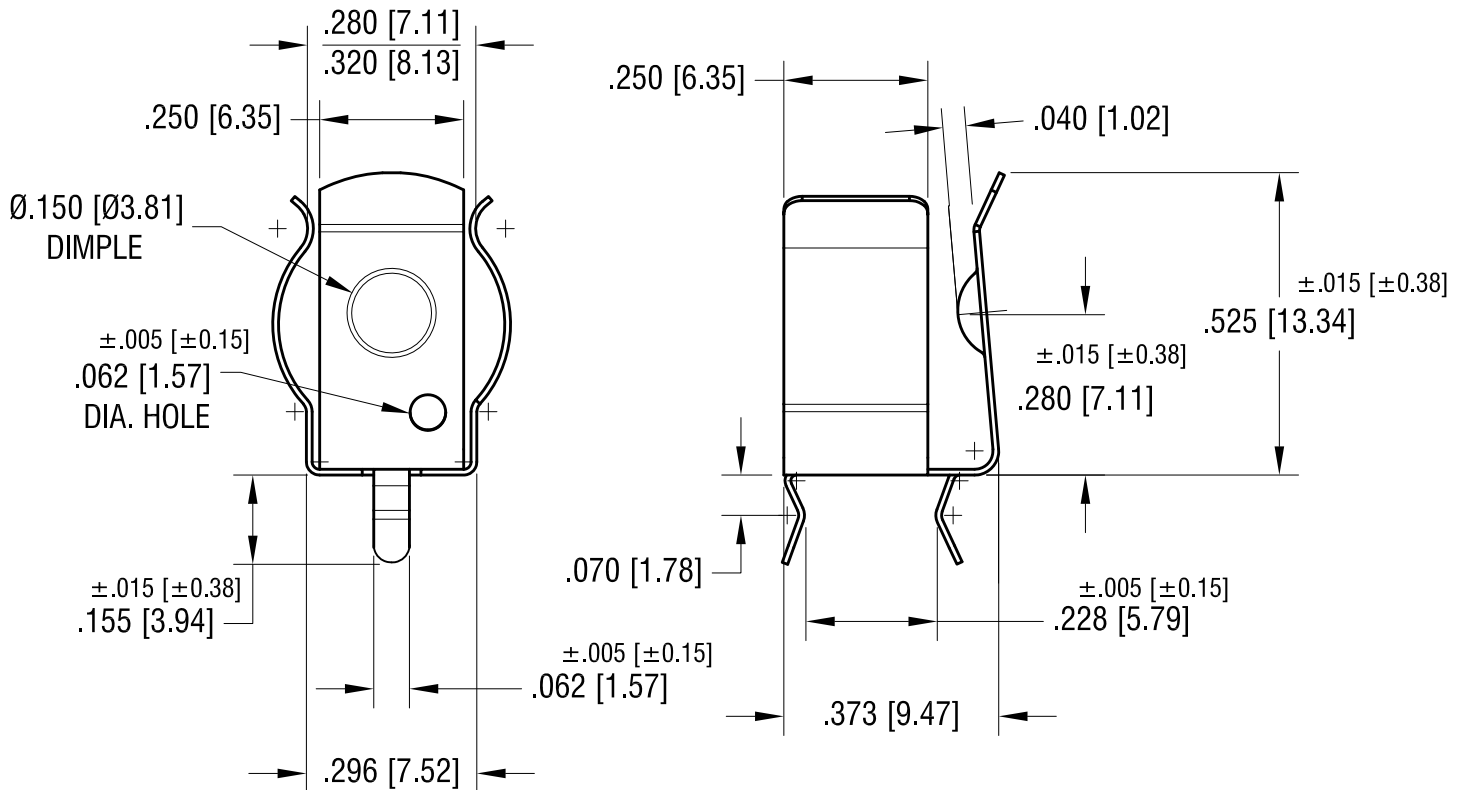
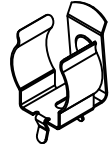

NOTE:

1. HEAT TREAT TO SPRING TEMPER.

DATE	DESCRIPTION	REV.
10.06.16	CHANGE AS PER ECR 16-063	R
10.05.15	CHANGE AS PER ECN15-112	P
7.17.14	CHANGE AS PER ECN14-069	N
6.28.13	CHANGE AS PER ECN 13-053	M
3.7.05	CHANGE AS PER ECN 05-015	L

<b>KEYSTONE ELECTRONICS CORP.</b>			
www.keyelco.com • ASTORIA, N.Y. 11105-2017 • Tel (718) 956-8900			
PART NAME		'AAA'-'N' PC BATTERY CLIP	
MATERIAL		.010 [.25] TH'K ANNEALED SPRING STEEL	
FINISH		DRN BY	DATE
TIN NICKEL PLATE		BOONE	2.3.98
		APP'D	SCALE
		LN	3X
TOLERANCES	INCH [MM]	CODE	DWG NO.
DECIMAL	± .010 [± 0.25]	C	<b>82</b>
ANGULAR	± 2°		
UNLESS OTHERWISE SPECIFIED			