

83.0mm X 15mm WATER RESISTANT LED MODULES

FEATURES

- VOLTAGE: 12V DC PER MODULE
- CURRENT: 100mA PER MODULE
- LED VIEWING ANGLE (2 θ 1/2): 120°
- MODULE THICKNESS: 6.0mm
- PACKAGE: 20 PIECES PER REEL
- WATER RESISTANCE - IP67

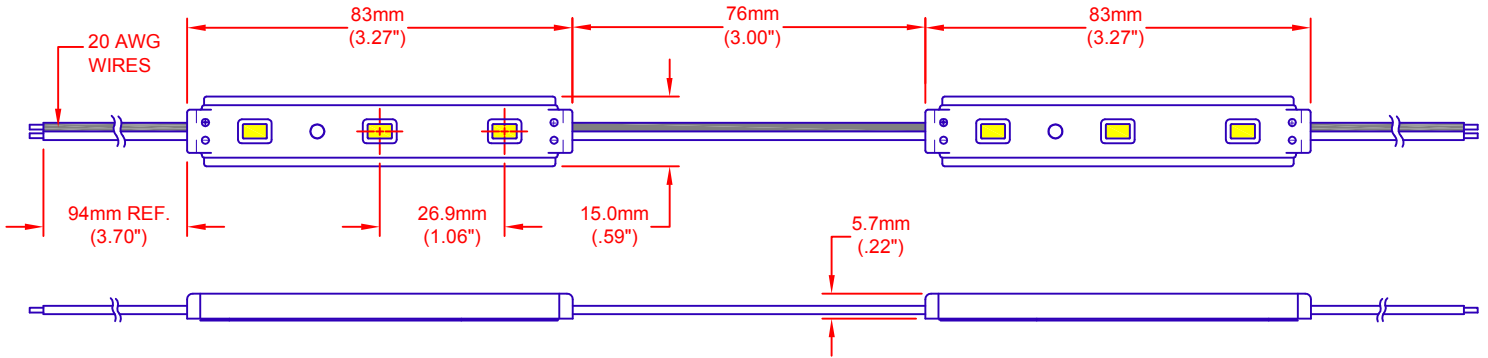

WIRES: WHITE WITH RED STRIP IS V+, PLAIN WHITE IS V-

Absolute Maximum Rating at TA = 25°C

Parameter	Symbol	Absolute MAX. Rating	Unit
Forward Current	IF	100	mA
Power Dissipation	PD	1.2	W
Electrostatic Discharge	ESD	800	V
Operating Temperature	Topr	-20~+60	°C
Storage Temperature	Tstg	-25~+80	°C

Electrical/Optical Characteristics at TA = 25°C

Parameter	Symbol	Condition	Min	Typ	Max	Unit
Forward Voltage DC	VF	IF = 100mA	--	12	--	V
Color Temperature	TC	IF = 100mA	--	9500	--	K
Luminous Flux per Module	φV/Mod	IF = 100mA	--	130	--	lm/mod
Luminous Flux per Ft.	φV/Ft	--	--	260	--	lm/ft
Recommend Forward Current	IF(rec)	--	--	100	--	mA

NOTES:

1. STANDARD MOUNTING INCLUDES ADHESIVE BACKING AND MOUNTING HOLE FOR A #3 SCREW (SCREWS NOT INCLUDED).
2. JKL ACCESSORIES TO BE ORDERED SEPARATELY: ZPS-1235 OR ZPS-1260 POWER SUPPLIES.
3. DUE TO WIRE GAUGE USED IN THE CONSTRUCTION OF THE MODULES SERIAL RUNS SHOULD BE LIMITED TO 11 FEET OR 20 MODULES.
4. POWER CONSUMPTION 2.4 WATTS PER FOOT.

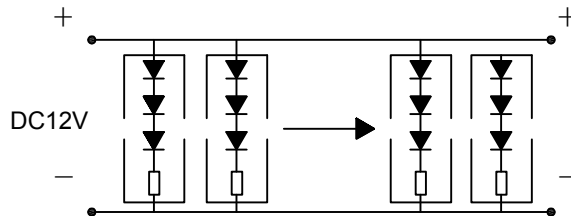

PLEASE REFER TO JKL APPLICATION SHEET: JKL-AS-ZM-CHANNEL-LED FOR INSTALLATION AND POWER RECOMMENDATIONS.

JKL PART NO.: ZM-8315-CW

ATTENTION



OBSERVE PRECAUTION FOR HANDLING ELECTROSTATIC DISCHARGE SENSITIVE DEVICES

METRIC	DIMENSIONS ARE IN mm & (INCHES)	
	TOLERANCE UNLESS OTHERWISE SPECIFIED	
THIRD ANGLE PROJECTION	1 PL +/- REF.	
	2 PL +/- ANGLE +/-	
DRAWN BY	APP'VD BY	DATE
L. WENGSTROM	L.R.	3/23/16
- CAD DRAWING -		
MANUAL REVISIONS NOT PERMITTED		

JKL COMPONENTS CORPORATION

TITLE
COOL WHITE 3-LED CHANNEL LIGHT

	CHANGE COLOR TEMP TO 9500 TYP.	3/23/16	DRAWN BY	APP'VD BY	DATE	SIZE	FSCM NO.	DRAWING NO.		
	RELEASED	2/28/16	L. WENGSTROM	L.R.	3/23/16	A	55335	ZM-8315-CW		
REV. NO.	DESCRIPTION/ECO NUMBER	APP'VD DATE	- CAD DRAWING -			SCALE	RELEASED DATE	REVISION DATE	REV. NO.	SHEET
			MANUAL REVISIONS NOT PERMITTED			NONE	2/28/16	3/23/16	A	1 OF 1