

High Power Infrared Emitting Diode, 940 nm, Surface Emitter Technology

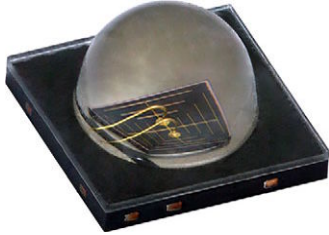

DESCRIPTION

As part of the [SurfLight™](#) portfolio, the VSMY99445DS is an infrared, 940 nm emitting diode based on surface emitter technology with high radiant power and high speed, molded in low thermal resistance SMD package with lens. A 42 mil chip provides outstanding radiant intensity and allows DC operation of the device up to 1 A. Superior ESD characteristics are ensured by an integrated Zener diode.

FEATURES

- Package type: surface mount
- Double stack technology
- Package form: high power SMD with lens
- Dimensions (L x W x H in mm): 3.85 x 3.85 x 2.24
- Peak wavelength: $\lambda_p = 940$ nm
- Zener diode for ESD protection up to 2 kV
- High radiant power
- High radiant intensity
- Angle of half intensity: $\phi = \pm 45^\circ$
- Designed for high drive currents: up to 1 A (DC) and up to 5 A pulses
- Low thermal resistance: $R_{thJP} = 10$ K/W
- Floor life: 168 h, MSL 3, acc. J-STD-020
- Lead (Pb)-free reflow soldering
- Material categorization: for definitions of compliance please see www.vishay.com/doc?99912



APPLICATIONS

- Infrared illumination for CMOS cameras (CCTV)
- Illumination for cameras (3D gaming)
- Machine vision

PRODUCT SUMMARY

COMPONENT	I_e (mW/sr)	ϕ (deg)	λ_p (nm)	t_r (ns)
VSMY99445DS	500	± 45	940	15

Note

- Test conditions see table “Basic Characteristics”

ORDERING INFORMATION

ORDERING CODE	PACKAGING	REMARKS	PACKAGE FORM
VSMY99445DS	Tape and reel	MOQ: 600 pcs, 600 pcs/reel	High power with lens

Note

- MOQ: minimum order quantity

ABSOLUTE MAXIMUM RATINGS ($T_{amb} = 25$ °C, unless otherwise specified)

PARAMETER	TEST CONDITION	SYMBOL	VALUE	UNIT
Reverse voltage		V_R	5	V
Forward current		I_F	1	A
Peak forward current	$t_p/T = 0.5, t_p = 100$ μ s	I_{FM}	2	A
Surge forward current	$t_p = 100$ μ s	I_{FSM}	5	A
Power dissipation		P_V	3.4	W
Junction temperature		T_J	110	°C
Operating temperature range		T_{amb}	-40 to +85	°C
Storage temperature range		T_{stg}	-55 to +100	°C
Soldering temperature	According to fig. 10, J-STD-20	T_{sd}	260	°C
Thermal resistance junction / pin	According to J-STD-051, soldered on PCB	R_{thJP}	10	K/W

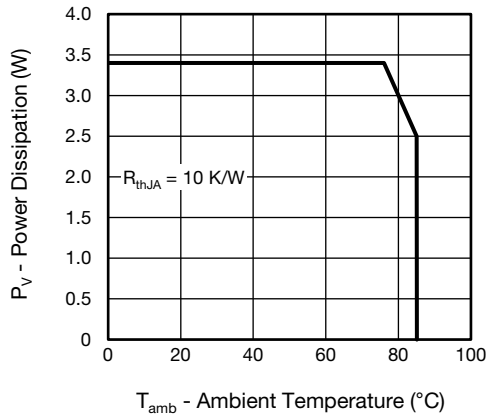

Fig. 1 - Power Dissipation Limit vs. Ambient Temperature

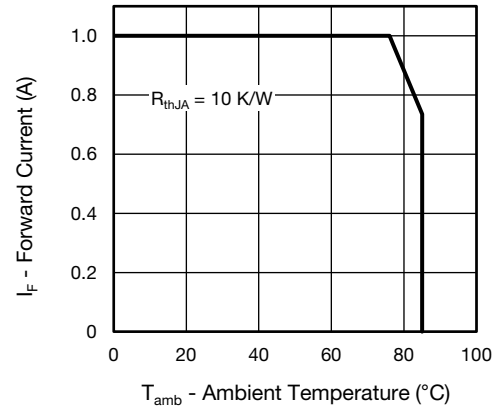

Fig. 2 - Forward Current Limit vs. Ambient Temperature

BASIC CHARACTERISTICS (T _{amb} = 25 °C, unless otherwise specified)						
PARAMETER	TEST CONDITION	SYMBOL	MIN.	TYP.	MAX.	UNIT
Forward voltage	I _F = 1 A, t _p = 20 ms	V _F	-	2.9	3.4	V
	I _F = 5 A, t _p = 100 μs	V _F	-	4.6	-	V
Temperature coefficient of V _F	I _F = 1 A	TK _{V_F}	-	-2.5	-	mV/K
Reverse current	V _R = 5 V	I _R	Not designed for reverse operation			μA
Radiant intensity	I _F = 1 A, t _p = 20 ms	I _e	320	500	900	mW/sr
	I _F = 5 A, t _p = 100 μs	I _e	-	2790	-	mW/sr
Radiant power	I _F = 1 A, t _p = 20 ms	φ _e	-	935	-	mW
Temperature coefficient of φ _e	I _F = 1 A	TK _{φ_e}	-	-0.2	-	%/K
Angle of half intensity		φ	-	± 45	-	deg
Peak wavelength	I _F = 1 A	λ _p	920	940	960	nm
Spectral bandwidth	I _F = 1 A	Δλ	-	50	-	nm
Temperature coefficient of λ _p	I _F = 1 A	TK _{λ_p}	-	0.3	-	nm/K
Rise time	I _F = 1 A	t _r	-	15	-	ns
Fall time	I _F = 1 A	t _f	-	18	-	ns

BASIC CHARACTERISTICS ($T_{amb} = 25\text{ }^{\circ}\text{C}$, unless otherwise specified)

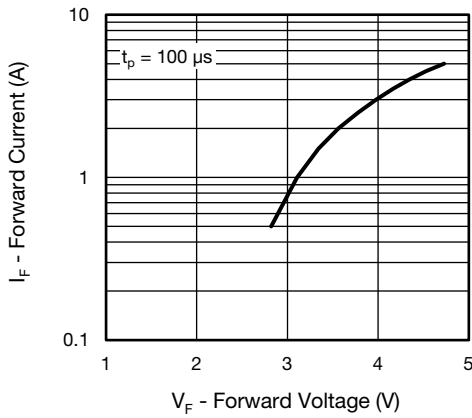

Fig. 3 - Forward Current vs. Forward Voltage

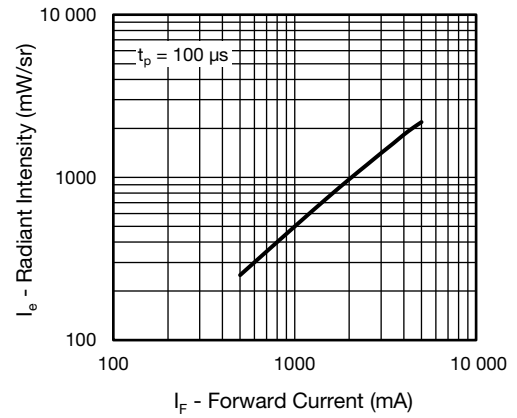

Fig. 6 - Radiant Intensity vs. Forward Current

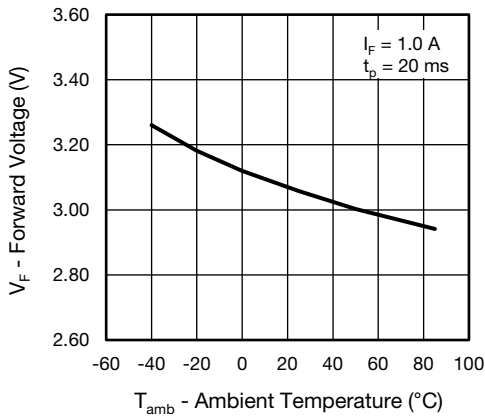

Fig. 4 - Forward Voltage vs. Ambient Temperature

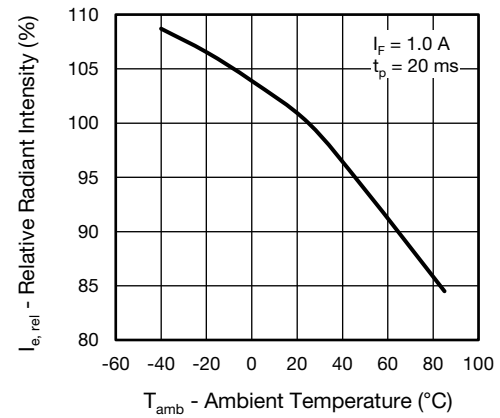

Fig. 7 - Relative Radiant Intensity vs. Ambient Temperature

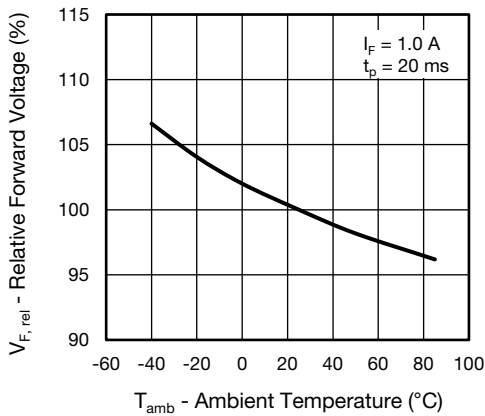

Fig. 5 - Relative Forward Voltage vs. Ambient Temperature

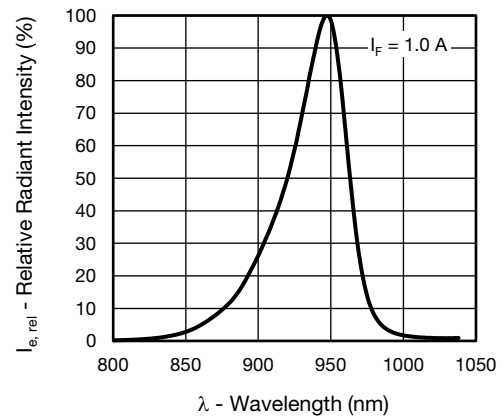

Fig. 8 - Relative Radiant Intensity vs. Wavelength

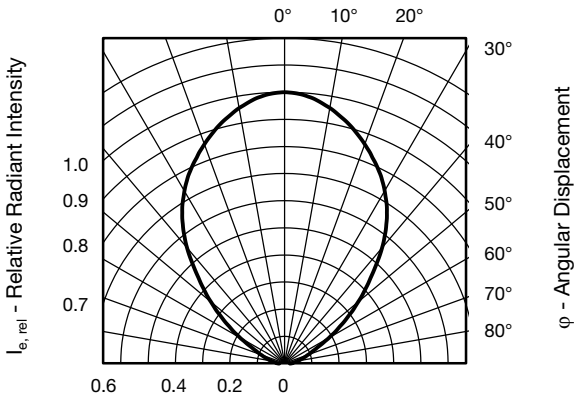
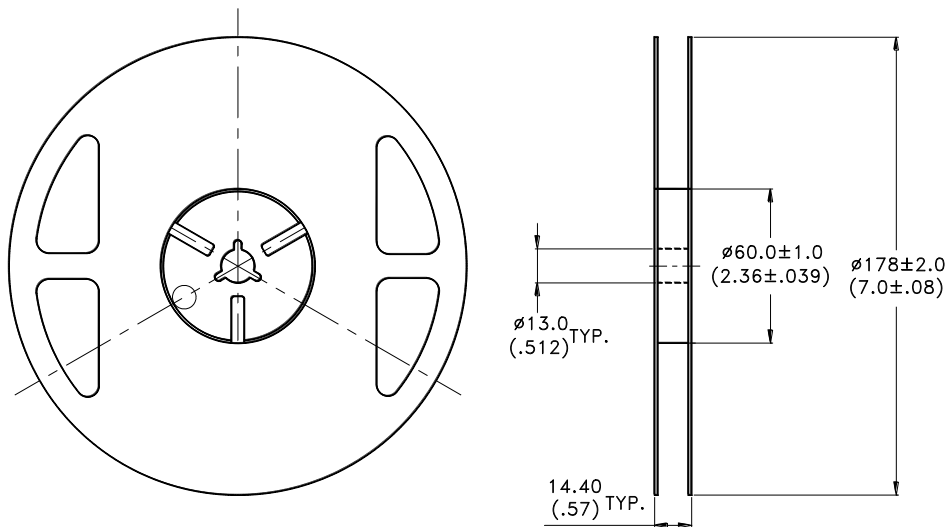

Fig. 9 - Relative Radiant Intensity vs. Angular Displacement

TAPING DIMENSIONS in millimeters



Notes

- Empty component pockets sealed with top cover tape.
- 7 inch reel - 600 pieces per reel.
- The maximum number of consecutive missing lamps is two.
- In accordance with ANSI/EIA 481-1-A-1994 specifications.

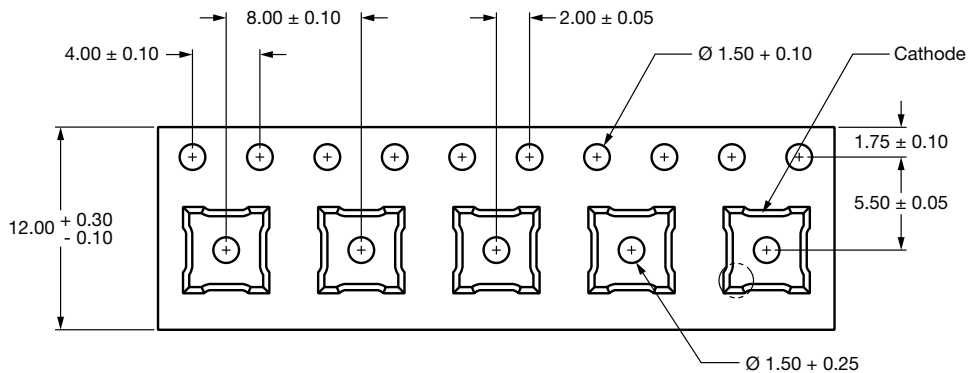



PACKAGE DIMENSIONS in millimeters

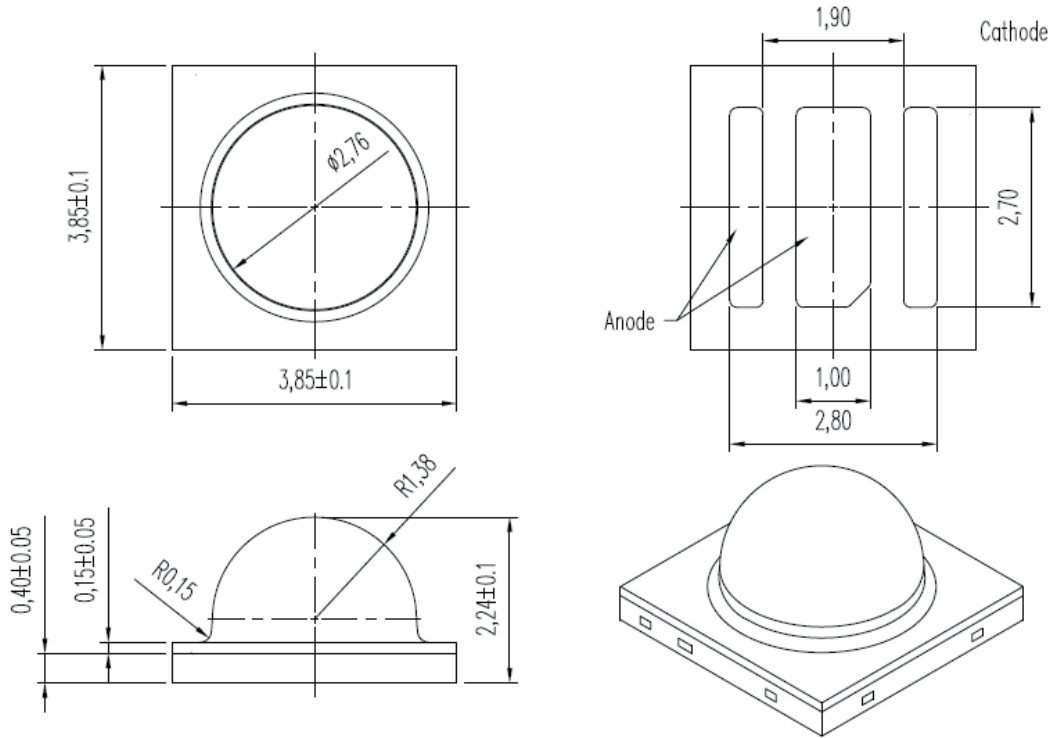

Notes

- Tolerance is ± 0.10 mm (0.004") unless otherwise noted.
- Specifications are subject to change without notice.

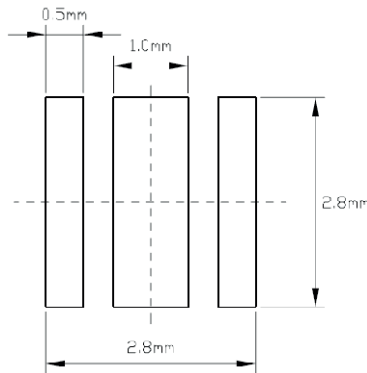

SOLDER PROFILE

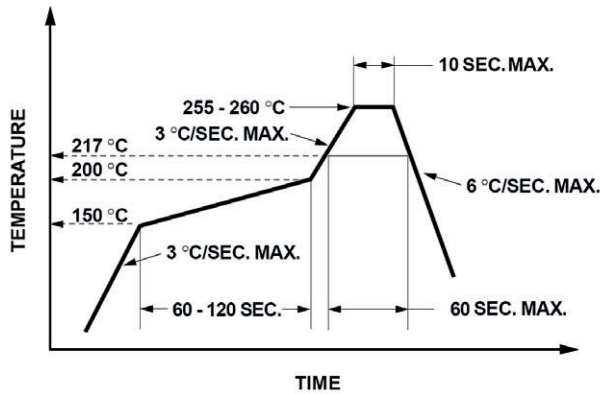

Fig. 10 - Lead (Pb)-free Reflow Solder Profile acc. J-STD-020

DRYPACK

Devices are packed in moisture barrier bags (MBB) to prevent the products from moisture absorption during transportation and storage. Each bag contains a desiccant.

FLOOR LIFE

Floor life (time between soldering and removing from MBB) must not exceed the time indicated on MBB label:

Floor life: 168 h

Conditions: $T_{amb} < 30\text{ °C}$, $RH < 60\%$

Moisture sensitivity level 3, acc. to J-STD-020B

DRYING

In case of moisture absorption devices should be baked before soldering. Conditions see J-STD-020 or label. Devices taped on reel dry using recommended conditions 192 h at 40 °C (+ 5 °C), $RH < 5\%$.



Disclaimer

ALL PRODUCT, PRODUCT SPECIFICATIONS AND DATA ARE SUBJECT TO CHANGE WITHOUT NOTICE TO IMPROVE RELIABILITY, FUNCTION OR DESIGN OR OTHERWISE.

Vishay Intertechnology, Inc., its affiliates, agents, and employees, and all persons acting on its or their behalf (collectively, "Vishay"), disclaim any and all liability for any errors, inaccuracies or incompleteness contained in any datasheet or in any other disclosure relating to any product.

Vishay makes no warranty, representation or guarantee regarding the suitability of the products for any particular purpose or the continuing production of any product. To the maximum extent permitted by applicable law, Vishay disclaims (i) any and all liability arising out of the application or use of any product, (ii) any and all liability, including without limitation special, consequential or incidental damages, and (iii) any and all implied warranties, including warranties of fitness for particular purpose, non-infringement and merchantability.

Statements regarding the suitability of products for certain types of applications are based on Vishay's knowledge of typical requirements that are often placed on Vishay products in generic applications. Such statements are not binding statements about the suitability of products for a particular application. It is the customer's responsibility to validate that a particular product with the properties described in the product specification is suitable for use in a particular application. Parameters provided in datasheets and/or specifications may vary in different applications and performance may vary over time. All operating parameters, including typical parameters, must be validated for each customer application by the customer's technical experts. Product specifications do not expand or otherwise modify Vishay's terms and conditions of purchase, including but not limited to the warranty expressed therein.

Except as expressly indicated in writing, Vishay products are not designed for use in medical, life-saving, or life-sustaining applications or for any other application in which the failure of the Vishay product could result in personal injury or death. Customers using or selling Vishay products not expressly indicated for use in such applications do so at their own risk. Please contact authorized Vishay personnel to obtain written terms and conditions regarding products designed for such applications.

No license, express or implied, by estoppel or otherwise, to any intellectual property rights is granted by this document or by any conduct of Vishay. Product names and markings noted herein may be trademarks of their respective owners.

Material Category Policy

Vishay Intertechnology, Inc. hereby certifies that all its products that are identified as RoHS-Compliant fulfill the definitions and restrictions defined under Directive 2011/65/EU of The European Parliament and of the Council of June 8, 2011 on the restriction of the use of certain hazardous substances in electrical and electronic equipment (EEE) - recast, unless otherwise specified as non-compliant.

Please note that some Vishay documentation may still make reference to RoHS Directive 2002/95/EC. We confirm that all the products identified as being compliant to Directive 2002/95/EC conform to Directive 2011/65/EU.

Vishay Intertechnology, Inc. hereby certifies that all its products that are identified as Halogen-Free follow Halogen-Free requirements as per JEDEC JS709A standards. Please note that some Vishay documentation may still make reference to the IEC 61249-2-21 definition. We confirm that all the products identified as being compliant to IEC 61249-2-21 conform to JEDEC JS709A standards.