

ITEM #	PART #	QTY	DESCRIPTION
1	AJ-156-11	1	HOUSING - JACK, CABLE
2	AJ-166-30	1	INSERT 6-COND, SOLDER
3	AP-105-5	1	STRAIN RELIEF
4	AP-116-3	1	WASHER, RUBBER
5	AP-116-7	1	ADAPTER, NUT
6	SEE TABLE #1	1	BUSHING
7	SEE TABLE #1	1	WASHER
8	SEE TABLE #1	1	SPRING
9	AP-116-6	1	STUD

B AJ-166

TABLE #1					
PART NUMBER	MILITARY PART NO.	CABLE DIA.	BUSHING	WASHER	SPRING
AJ-166/14-1	M55116/14-1	.165± .010	AP-116-17	AP-116-2	AP-116-4
AJ-166/14-2	M55116/14-2	.228± .010	AP-116-18	AP-116-2	AP-116-4
AJ-166/14-3	M55116/14-3	.250± .010	AP-116-8	AP-116-2	AP-116-4
AJ-166/14-4	M55116/14-4	.290± .010	AP-116-19	AP-116-2	AP-116-4
AJ-166/14-5	M55116/14-5	.320± .010	AP-116-20	AP-116-22	AP-116-21

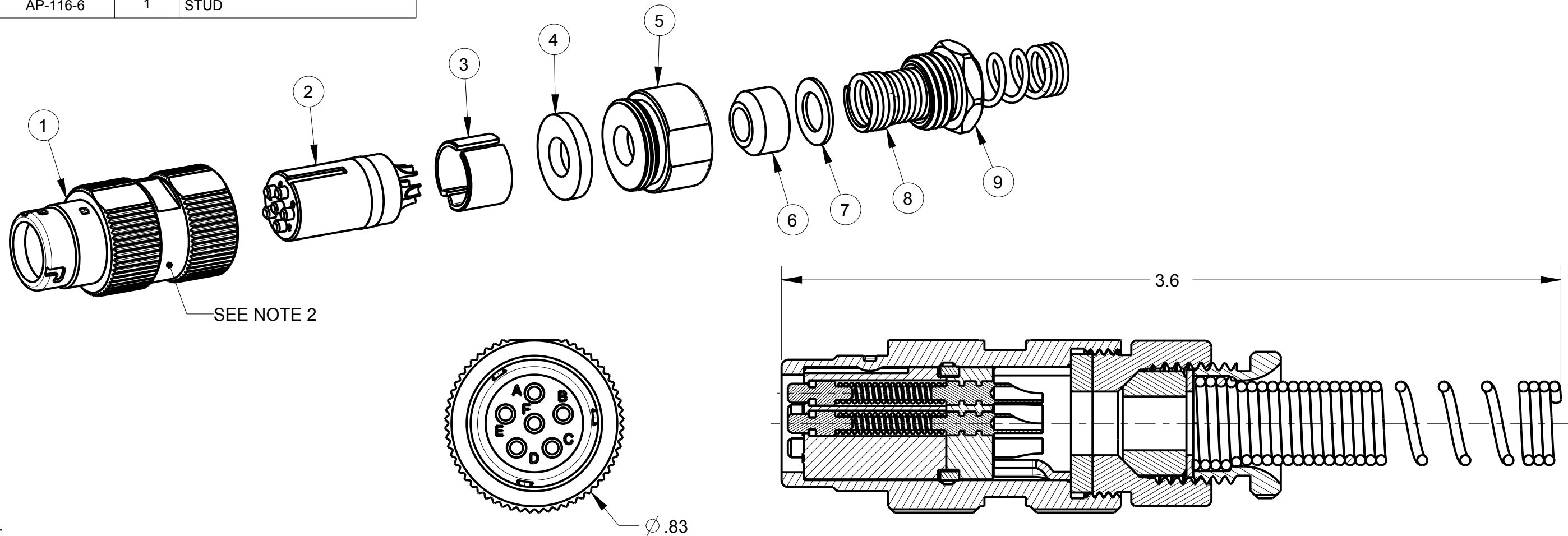

NOTES;
 1. CONNECTORS ARE QUALIFIED TO MIL-DTL-55116.
 2. MARK MILITARY PART IDENTIFYING NO., MANUFACTURERS NAME AND CAGE CODE LOCATED APPROXIMATELY AS SHOWN.

THIS DOCUMENT CONTAINS PROPRIETARY INFORMATION OF NEXUS, INCORPORATED AND SUCH INFORMATION MAY NOT BE DISCLOSED TO OTHERS FOR ANY PURPOSE OR USED FOR ANY PURPOSE WITHOUT THE WRITTEN CONSENT OF NEXUS.

LET.	REVISION	CN #	DATE	CHK.
C	ADD: AJ-166/14-5	213	10/7 2014	HR
B	UNDER BUSHING "SEE TABLE" WAS "SEE NOTE 2".	040	1/4/10	GPH
A	ADD NOTES 1 AND 2 AND TABLE	037	12/18/09	GPH

DWN.BY	GPH	DATE	13-Jul-09
CHECKED BY		DATE	
APPR.BY		DATE	
UNLESS OTHERWISE SPECIFIED: DIMENSIONS ARE IN INCHES &/OR (mm)			
TOLERANCES:			
DECIMAL: .XX[X.X] .XXX[X.XX]		± .01[0.3] ± .003[0.08]	
FRACTION: X/X		ANGLES: .X ± .5°	

MATERIAL	
FINISH	
WEIGHT —	SCALE = 2.00 :1
TITLE	
JACK, 6 PIN AUDIO, SOLDER CUP	
DO NOT SCALE DWG.	SHEET 1 OF 1

NEXUS
STAMFORD, CONN

SIZE **B** DWG. NO. AJ-166