

### FEATURES:

- Accommodates MCA (Microchannel Architecture) Daughter Boards for IBM PS/2 Systems
- .050" (1.27mm) Contact Spacing with Staggered Tail Bend Results in 4 Rows at .100" (2.54mm) Spacing
- Accepts .062" (1.57mm) Nominal Thickness P.C. Board, Accurately Positioned by Card Slot Barrier
- High Profile Insulator Body, .610" (15.49mm)
- Mounting Posts Provide Positive Location and Retention
- P.C. Tail Contact Termination
- Many other sizes available. Contact EDAC for additional items
- RoHS Compliant

### Specifications:

Insulator Material	UL 94V-0 Polyphenylene Sulfide, Color: Black
Contact Material	Copper Alloy
Contact Plating	Gold Plating on mating area and Tin Plating on tails with Nickel underplating all over
Current Rating	1 Amperes
Contact Resistance	30 milliohms maximum
Dielectric Withstand Voltage	500 VAC rms at sea level between adjacent contacts
Insulation Resistance	1000 Megohms minimum
Operating Temperature	-40°C to +125°C
Insertion Force	8oz (2.22N) maximum per contact pair when tested with .062" (1.57mm) thick gauge
Withdrawal Force	1oz (0.28N) minimum per contact pair when tested with .062" (1.57mm) thick gauge

Example Part Number: **302-182-520-201**



Contact Code	Description & Tail Size	Tail Length "G"
520	P.C. Tail	.118 (3.00)
521	P.C. Tail	.190 (4.83)

Style	Description
201	3.3V PCI With Plastic Guide Pins
205	3.3V PCI With Metal Board locks
301	5.0V PCI With Plastic Guide Pins

Series: **302**

Total Number of Contacts:	Descriptions
112	Divided in Groups of 90 & 22 Contacts
132	Divided in Groups of 20, 90 & 22 Contacts
182	Divided in Groups of 98 & 84 Contacts

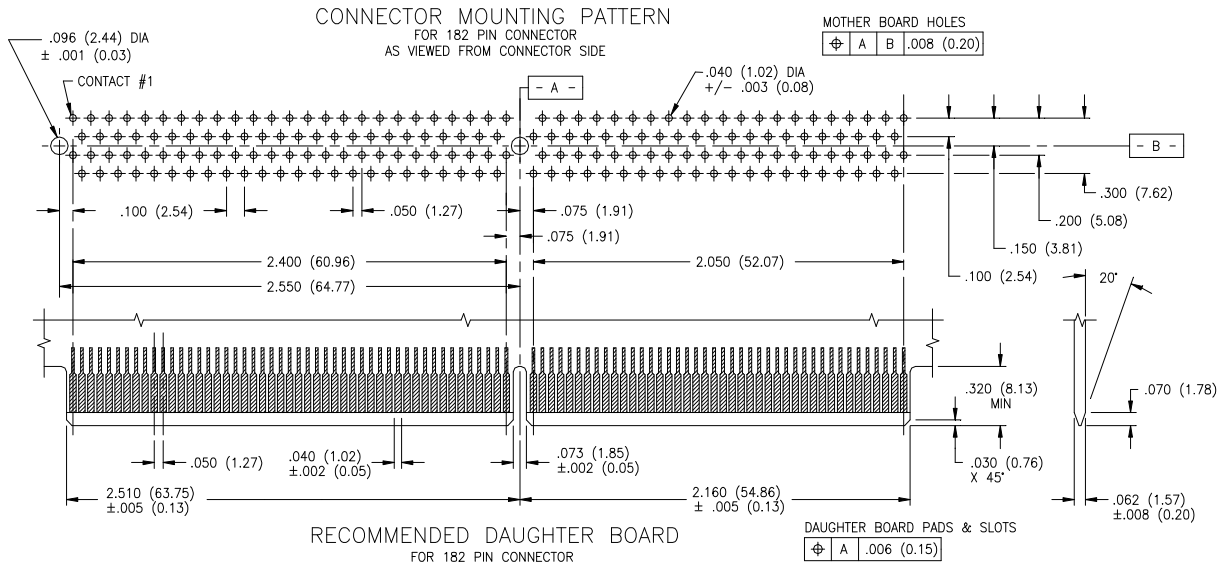

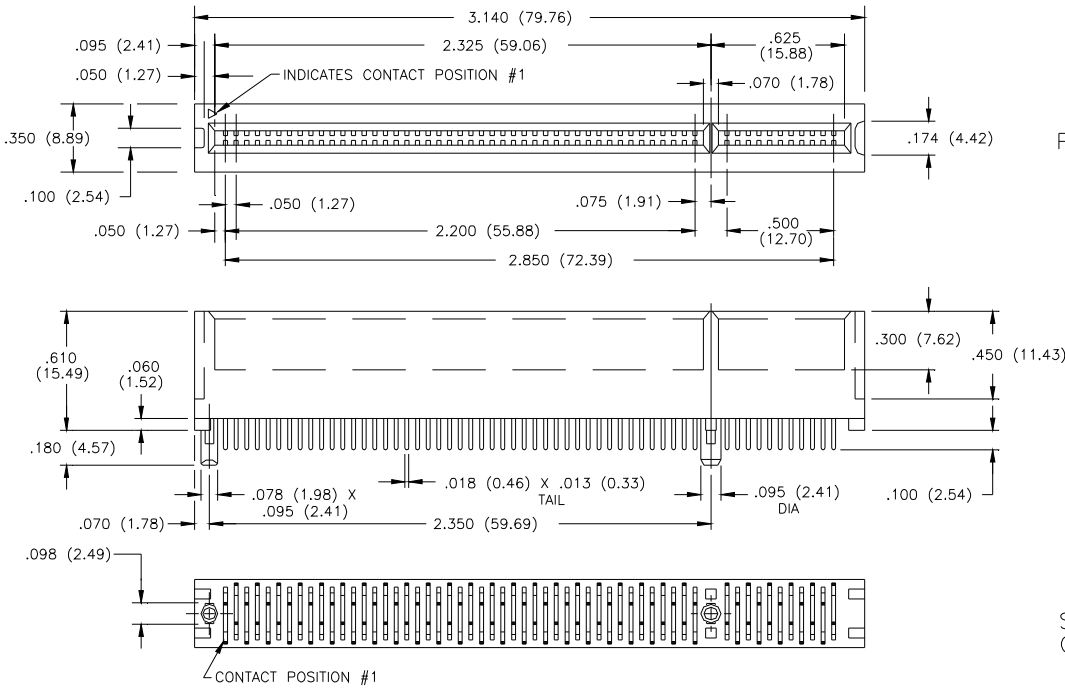

P/N 302-112-520-201

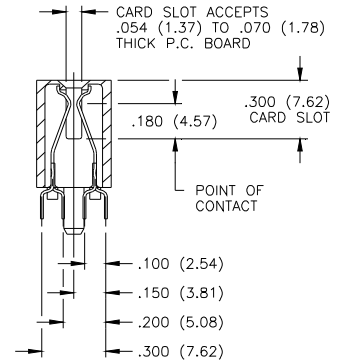

SECTION THROUGH CONTACT POSITION

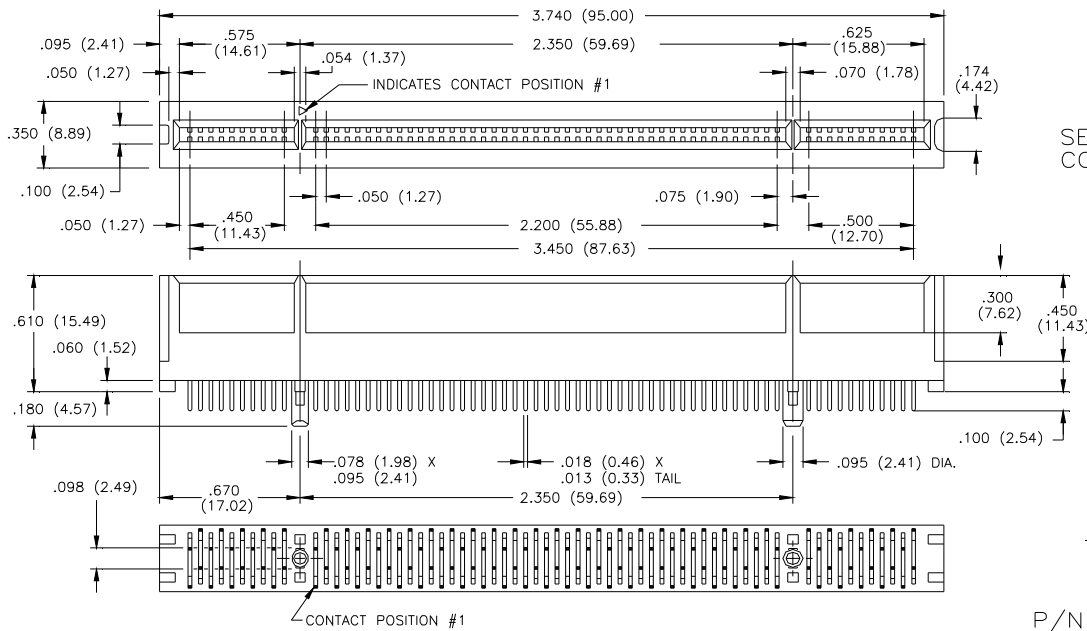

SECTION THROUGH CONTACT POSITION

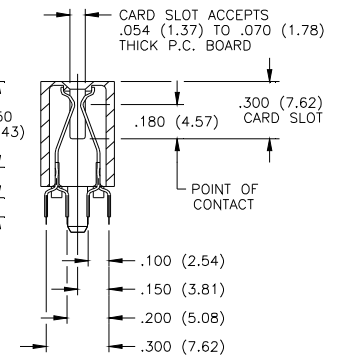

P/N 302-132-520-201

