

THE INFORMATION CONTAINED HEREIN IS CONSIDERED "PROPRIETARY" TO BEL FUSE INC. AND SHALL NOT BE COPIED, REPRODUCED OR DISCLOSED WITHOUT THE WRITTEN APPROVAL OF BEL FUSE INC.

RoHS



LED1 POLARITY			LED2 POLARITY		
PIN 7	PIN 8	COLOR	PIN 9	PIN 10	COLOR
-	+	GREEN	-	+	GREEN

ELECTRICAL CHARACTERISTICS @ 25°C

TRANS RATIO					
TX	1CT : 1				
RX	1CT : 1				
OCL @ 100kHz/100mVRMS		350µH MIN.			
8mA DC BIAS					
INS. LOSS					
1MHz TO 100MHz		-1.0 dB MAX			
RET. LOSS (MIN)					
1MHz-30MHz		-18 dB			
30MHz-60MHz		-18+20LOG(F/30MHz) dB			
60MHz-80MHz		-12 dB			
CROSS TALK (TX - RX)					
500kHz-1MHz		-70 dB MIN			
10 MHz		-50 dB MIN			
30 MHz		-45 dB MIN			
50 MHz		-40 dB MIN			
100 MHz		-35 dB MIN			
CM TO CM REJ					
100kHz-1MHz		-70 dB MIN			
10 MHz		-47 dB MIN			
30 MHz		-42 dB MIN			
60 MHz		-37 dB MIN			
100 MHz		-30 dB MIN			
CM TO DM REJ					
100kHz-1MHz		-70 dB MIN			
10 MHz		-60 dB MIN			
30 MHz		-50 dB MIN			
60 MHz		-45 dB MIN			
100 MHz		-40 dB MIN			
HIPOT (Isolation Voltage):		1500 Vrms			
LED 1 & LED 2					
VF (FORWARD VOLTAGE)	IF=20mA	GREEN	2.2V TYP.		
λD (DOMINANT WAVELENGTH)	IF=20mA	GREEN	570nm TYP.		

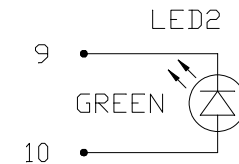
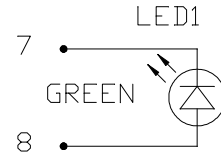

SCHEMATIC

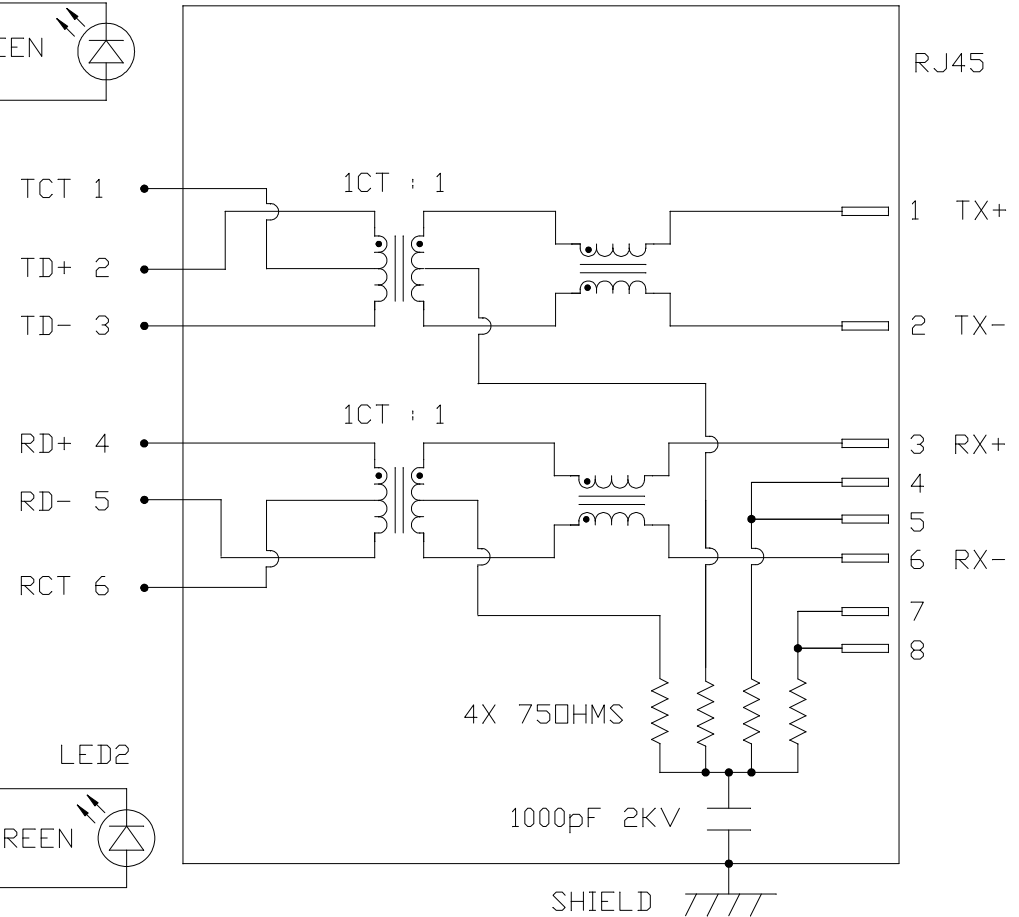

ORIGINATED BY
CHOW WAN CHUNG
DATE 2014-01-07

DRAWN BY
HU XIANG
DATE 2014-01-07

TITLE
MagJack®
(4 Cores, MDIX, CM Termination)

08B0-1G1T-36-F
PATENTED

PART NO. / DRAWING NO.
08B01G1T36-F

FILE NAME
08B01G1T36-F_B.DWG

STANDARD DIM.
TOL. IN INCH

[] METRIC DIM.
AS REF.

.X UNIT : INCH [mm]
.XX SCALE : N/A
.XXX SIZE : A4

REV. : B PAGE : 2

a bel group

THE INFORMATION CONTAINED HEREIN IS CONSIDERED "PROPRIETARY" TO BEL FUSE INC. AND SHALL NOT BE COPIED, REPRODUCED OR DISCLOSED WITHOUT THE WRITTEN APPROVAL OF BEL FUSE INC.

MECHANICAL SPECIFICATION

RoHS

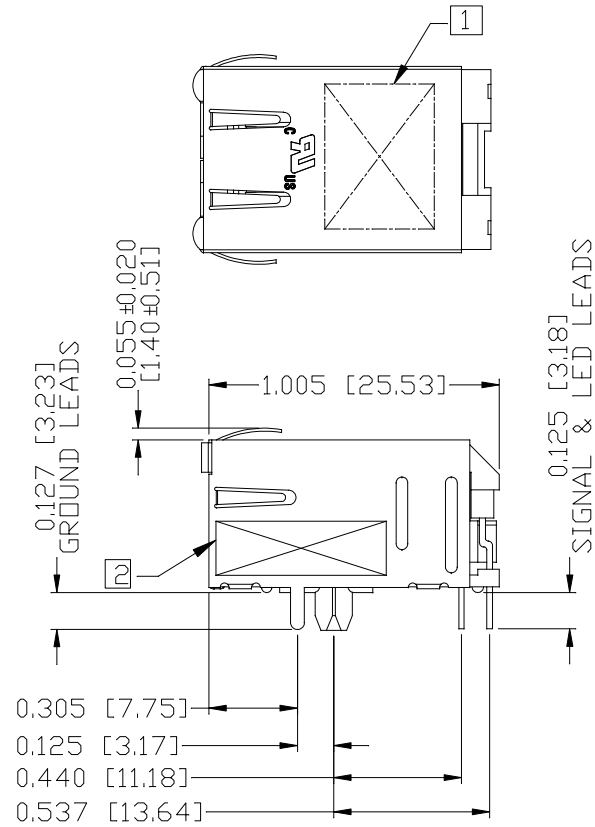
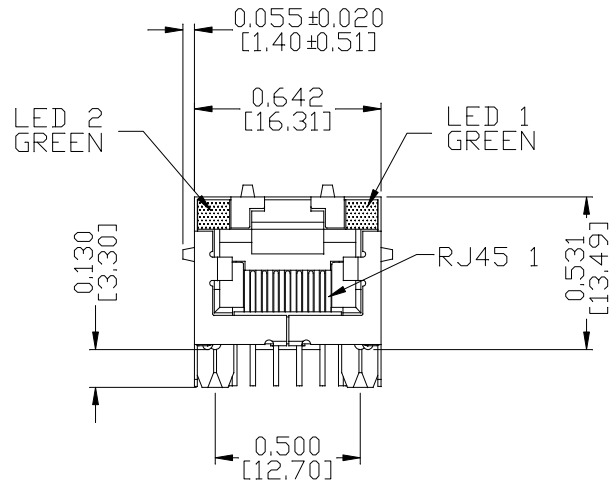

NOTES:

- PLASTIC HOUSING: THERMOPLASTIC PBT
FLAMMABILITY RATING UL 94V-0
- CONTACTS PLATING: 15 MICRO-INCH HARD GOLD PLATING OR EQUIVALENT.
- PINS: TIN-COATED COPPER WIRE, DIA 0.018 INCH.
- METAL SHIELD: PRE-PLATED NICKEL ON COPPER ALLOY.
(ALL GROUND LEADS ARE SOLDER DIPPED)

1] MARK PART WITH MFG LOGO, MFG NAME, PART NUMBER, AND DATE CODE.

- 2] "PATENTED" MARKING.
- 3. THE PRODUCT IS RoHS COMPLIANT.

UL UL RECOGNIZED - FILE #E196366 AND E169987.

- 4. JACK CAVITY CONFORMS TO FCC RULES AND REGULATIONS.
- 5. THE PRODUCT IS PATENTED. THE PATENT NUMBER IS U.S. PAT. 5,736,910.

ORIGINATED BY ANTON LIAO DATE 2014-01-07	TITLE MagJack® (4 Cores, MDIX, CM Termination)	PART NO. / DRAWING NO. 08B01G1T36-F	STANDARD DIM. TOL. IN INCH	[] METRIC DIM. AS REF.	REV. : B	PAGE : 3
DRAWN BY JESSE LI DATE 2014-01-07	08B0-1G1T-36-F PATENTED	FILE NAME 08B01G1T36-F_B.DWG	.X	UNIT : INCH [mm]		
			.XX	SCALE : N/A		
			.XXX	±0.010		

THE INFORMATION CONTAINED HEREIN IS CONSIDERED "PROPRIETARY" TO BEL FUSE INC. AND SHALL NOT BE COPIED, REPRODUCED OR DISCLOSED WITHOUT THE WRITTEN APPROVAL OF BEL FUSE INC.

RoHS



RECOMMENDED PCB FOOTPRINT
COMPONENT SIDE VIEW

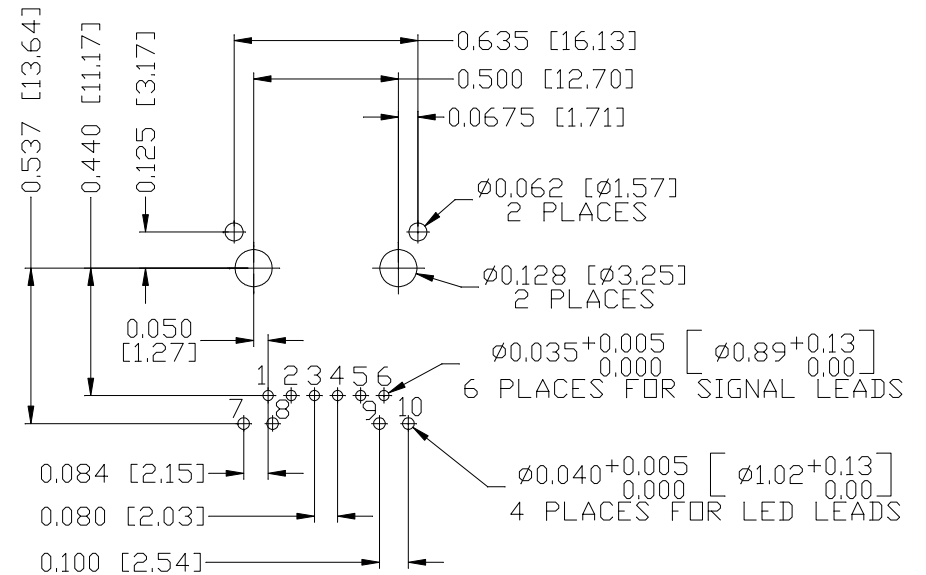
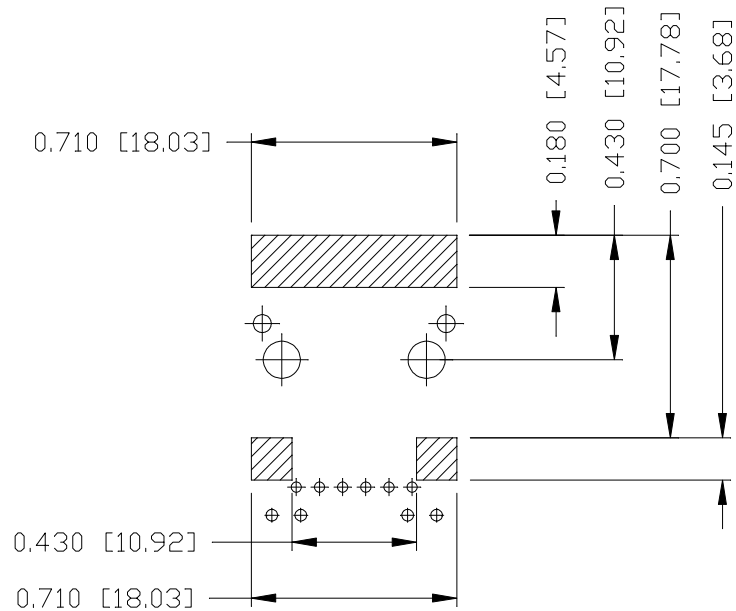

NOTES:

THE SHADED AREA ON THE CUSTOMER BOARD ARE RECOMMENDED TO BE CLEAR OFF ANY VIA HOLE OR COMPONENT PAD.

REV. :	B	PAGE :	4

ORIGINATED BY ANTON LIAD DATE 2014-01-07	TITLE MagJack® (4 Cores, MDIX, CM Termination)	PART NO. / DRAWING NO. 08B01G1T36-F	STANDARD DIM. TOL. IN INCH	[] METRIC DIM. AS REF.
DRAWN BY JESSE LI DATE 2014-01-07	08B0-1G1T-36-F PATENTED	FILE NAME 08B01G1T36-F_B.DWG	.X .XX .XXX	UNIT : INCH [mm] SCALE : N/A SIZE : A4
			±0.004	

THE INFORMATION CONTAINED HEREIN IS CONSIDERED "PROPRIETARY" TO BEL FUSE INC. AND SHALL NOT BE COPIED, REPRODUCED OR DISCLOSED WITHOUT THE WRITTEN APPROVAL OF BEL FUSE INC.

RoHS



SUGGESTED PANEL OPENING

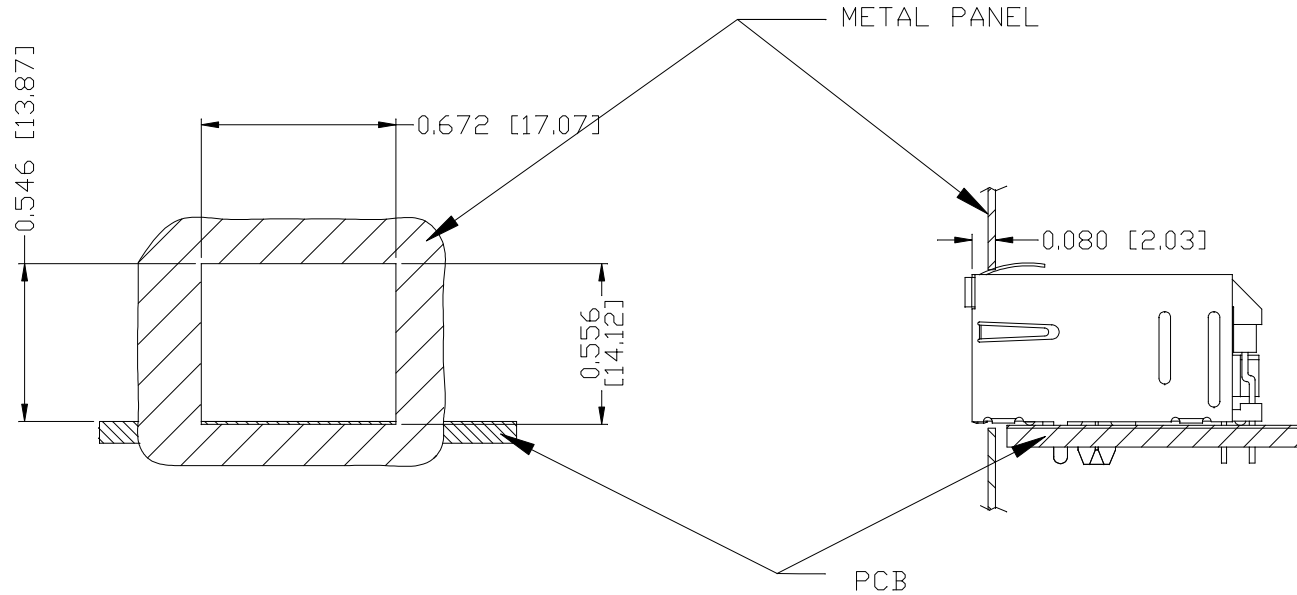

NOTE:

THE DISTANCE OF PANEL INSIDE SURFACE RELATIVE TO FRONT SURFACE OF PART IS ONLY A SUGGESTION. IN CASE THIS DISTANCE IS DIFFERENT, THE REQUIRED PANEL OPENING DIMENSIONS CHANGE ACCORDINGLY.

PACKING INFORMATION

PACKING TRAY : 0200-9999-D4(TOP)

0200-9999-D5(BOTTOM)

PACKING QUANTITY : 60 PCS FINISHED GOODS PER TRAY

11 TRAYS (660 PCS FINISHED GOODS) PER CARTON BOX

NOTE : CARDBOARDS ARE PLACED BETWEEN LAYERS OF PACKING TRAY INSIDE CARTON BOX

(INCLUDE THE UPPERMOST AND LOWERMOST TRAY)

REV. :	B	PAGE :	5
		[] METRIC DIM. AS REF.	
		UNIT : INCH [mm]	
		SCALE : N/A	
		SIZE : A4	

ORIGINATED BY ANTON LIAO	TITLE MagJack® (4 Cores, MDIX, CM Termination)	PART NO. / DRAWING NO. 08B01G1T36-F	STANDARD DIM. TOL. IN INCH	[] METRIC DIM. AS REF.
DATE 2014-01-07		FILE NAME 08B01G1T36-F_B.DWG	.X	UNIT : INCH [mm]
DRAWN BY JESSE LI	08B0-1G1T-36-F PATENTED		.XX	SCALE : N/A
DATE 2014-01-07			.XXX ±0.004	SIZE : A4