

Features

- Fast read access time – 90ns
- Dual voltage range operation
 - Low voltage power supply range, 3.0V to 3.6V, or
 - Standard power supply range, 5V \pm 10%
- Compatible with JEDEC standard Atmel® AT27C256R
- Low-power CMOS operation
 - 20 μ A max standby (less than 1 μ A, typical) for V_{CC} = 3.6V
 - 29mW max active at 5MHz for V_{CC} = 3.6V
- JEDEC standard package
 - 32-lead PLCC
- High-reliability CMOS technology
 - 2,000V ESD protection
 - 200mA latchup immunity
- Rapid programming algorithm – 100 μ s/byte (typical)
- CMOS- and TTL-compatible inputs and outputs
 - JEDEC standard for LVTTL
- Integrated product identification code
- Industrial temperature range
- Green (Pb/halide-free) packaging option

1. Description

The Atmel AT27LV256A is a high-performance, low-power, low-voltage, 262,144-bit, one-time programmable, read-only memory (OTP EPROM) organized as 32K by 8 bits. It requires only one supply in the range of 3.0V to 3.6V in normal read mode operation, making it ideal for fast, portable systems using battery power.

The Atmel innovative design techniques provide fast speeds that rival 5V parts, while keeping the low power consumption of a 3.3V supply. At V_{CC} = 3.0V, any byte can be accessed in less than 90ns. With a typical power dissipation of only 18mW at 5MHz and V_{CC} = 3.3V, the AT27LV256A consumes less than one-fifth the power of a standard, 5V EPROM. Standby mode supply current is typically less than 1 μ A at 3.3V.

The AT27LV256A is available in an industry-standard, JEDEC-approved, one-time programmable (OTP) PLCC package. All devices feature two-line control (\overline{CE} , \overline{OE}) to give designers the flexibility to prevent bus contention.

The AT27LV256A operating with V_{CC} at 3.0V produces TTL-level outputs that are compatible with standard TTL logic devices operating at V_{CC} = 5.0V. The device is also capable of standard, 5V operation, making it ideally suited for dual supply range systems or card products that are pluggable in both 3V and 5V hosts.

The AT27LV256A has additional features to ensure high quality and efficient production use. The rapid programming algorithm reduces the time required to program the part and guarantees reliable programming. Programming time is typically only 100 μ s/byte. The integrated product identification code electronically identifies the device and manufacturer. This feature is used by industry standard programming equipment to select the proper programming algorithms and voltages. The AT27LV256A programs in exactly the same way as a standard, 5V Atmel AT27C256R, and uses the same programming equipment.



256K (32K x 8)
Low Voltage,
One-time
Programmable,
Read-only Memory

Atmel AT27LV256A



2. Pin configurations

Pin name	Function
A0 - A14	Addresses
O0 - O7	Outputs
\overline{CE}	Chip Enable
\overline{OE}	Output Enable
NC	No Connect

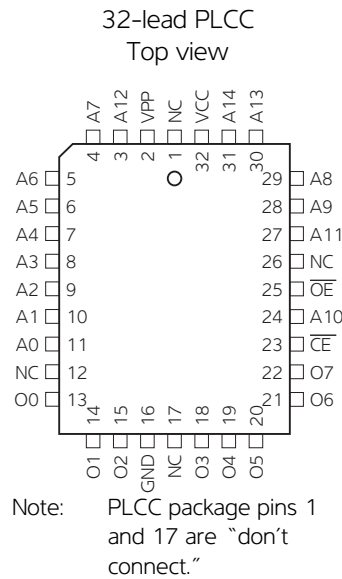

3. System considerations

Switching between active and standby conditions via the chip enable pin may produce transient voltage excursions. Unless accommodated by the system design, these transients may exceed datasheet limits, resulting in device nonconformance. At a minimum, a 0.1 μ F, high-frequency, low inherent inductance, ceramic capacitor should be utilized for each device. This capacitor should be connected between the V_{CC} and ground terminals of the device, as close to the device as possible. Additionally, to stabilize the supply voltage level on printed circuit boards with large EPROM arrays, a 4.7 μ F bulk electrolytic capacitor should be utilized, again connected between the V_{CC} and ground terminals. This capacitor should be positioned as close as possible to the point where the power supply is connected to the array.

Figure 3-1. Block diagram

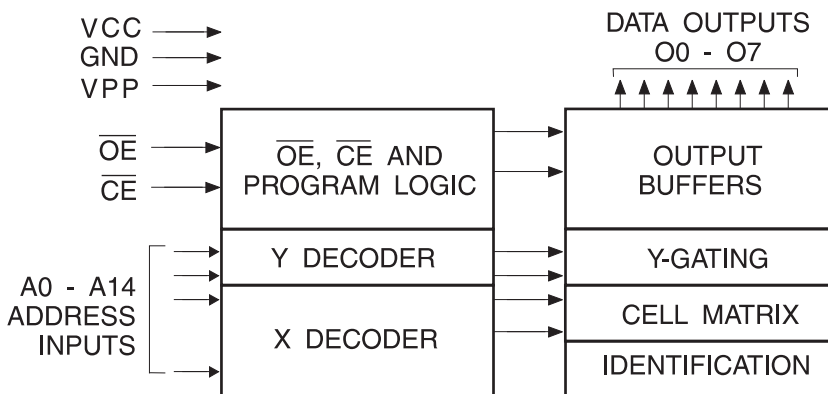

4. Absolute maximum ratings*

Temperature under bias	-40°C to +85°C
Storage temperature	-65°C to +125°C
Voltage on any pin with respect to ground	-2.0V to +7.0V ⁽¹⁾
Voltage on A9 with respect to ground	-2.0V to +14.0V ⁽¹⁾
V _{pp} supply voltage with respect to ground	-2.0V to +14.0V ⁽¹⁾

*NOTICE: Stresses beyond those listed under “Absolute maximum ratings” may cause permanent damage to the device. This is a stress rating only, and functional operation of the device at these or any other conditions beyond those indicated in the operational sections of this specification is not implied. Exposure to absolute maximum rating conditions for extended periods may affect device reliability.

Note: 1. Minimum voltage is -0.6V DC, which may undershoot to -2.0V for pulses of less than 20ns. Maximum output pin voltage is V_{CC} + 0.75V DC, which may be exceeded if certain precautions are observed (consult application notes), and which may overshoot to +7.0V for pulses of less than 20ns.

5. DC and AC characteristics

Table 5-1. Operating modes

Mode/Pin	\overline{CE}	\overline{OE}	Ai	V _{pp}	V _{CC}	Outputs
Read ⁽²⁾	V _{IL}	V _{IL}	Ai	V _{CC}	V _{CC}	D _{OUT}
Output disable ⁽²⁾	V _{IL}	V _{IH}	X ⁽¹⁾	V _{CC}	V _{CC}	High Z
Standby ⁽²⁾	V _{IH}	X ⁽¹⁾	X ⁽¹⁾	V _{CC}	V _{CC}	High Z
Rapid program ⁽³⁾	V _{IL}	V _{IH}	Ai	V _{pp}	V _{CC}	D _{IN}
PGM verify ⁽³⁾	X ⁽¹⁾	V _{IL}	Ai	V _{pp}	V _{CC}	D _{OUT}
Optional PGM verify ⁽³⁾	V _{IL}	V _{IL}	Ai	V _{CC}	V _{CC}	D _{OUT}
PGM inhibit ⁽³⁾	V _{IH}	V _{IH}	X ⁽¹⁾	V _{pp}	V _{CC}	High Z
Product identification ⁽³⁾⁽⁵⁾	V _{IL}	V _{IL}	A9 = V _H ⁽⁴⁾ A0 = V _{IH} or V _{IL} A1 - A14 = V _{IL}	V _{CC}	V _{CC}	Identification code

- Notes:
- X can be V_{IL} or V_{IH}.
 - Read, output disable, and standby modes require 3.0V ≤ V_{CC} ≤ 3.6V or 4.5V ≤ V_{CC} ≤ 5.5V.
 - Refer to programming characteristics. Programming modes require V_{CC} = 6.5V.
 - V_H = 12.0 ± 0.5V.
 - Two identifier bytes may be selected. All Ai inputs are held low (V_{IL}) except A9, which is set to V_H, and A0, which is toggled low (V_{IL}) to select the manufacturer’s identification byte and high (V_{IH}) to select the device code byte.

Table 5-2. DC and AC operating conditions for read operation

	Atmel AT27LV256A	
	-90	
Industrial operating temperature (case)	-40°C - 85°C	
V _{CC} power supply	3.0V to 3.6V	
	5V ± 10%	

Table 5-3. DC and operating characteristics for read operation

Symbol	Parameter	Condition	Min	Max	Units
$V_{CC} = 3.0V$ to $3.6V$					
I_{LI}	Input load current	$V_{IN} = 0V$ to V_{CC}		± 1	μA
I_{LO}	Output leakage current	$V_{OUT} = 0V$ to V_{CC}		± 5	μA
$I_{PP1}^{(2)}$	$V_{PP}^{(1)}$ read/standby current	$V_{PP} = V_{CC}$		10	μA
I_{SB}	$V_{CC}^{(1)}$ standby current	I_{SB1} (CMOS), $\overline{CE} = V_{CC} \pm 0.3V$		20	μA
		I_{SB2} (TTL), $\overline{CE} = 2.0$ to $V_{CC} + 0.5V$		100	μA
I_{CC}	V_{CC} active current	$f = 5MHz$, $I_{OUT} = 0mA$, $\overline{CE} = V_{IL}$		8	mA
V_{IL}	Input low voltage		-0.6	0.8	V
V_{IH}	Input high voltage		2.0	$V_{CC} + 0.5$	V
V_{OL}	Output low voltage	$I_{OL} = 2.0mA$		0.4	V
V_{OH}	Output high voltage	$I_{OH} = -2.0mA$	2.4		V
$V_{CC} = 4.5V$ to $5.5V$					
I_{LI}	Input load current	$V_{IN} = 0V$ to V_{CC}		± 1	μA
I_{LO}	Output leakage current	$V_{OUT} = 0V$ to V_{CC}		± 5	μA
$I_{PP1}^{(2)}$	$V_{PP}^{(1)}$ read/standby current	$V_{PP} = V_{CC}$		10	μA
I_{SB}	$V_{CC}^{(1)}$ standby current	I_{SB1} (CMOS), $\overline{CE} = V_{CC} \pm 0.3V$		100	μA
		I_{SB2} (TTL), $\overline{CE} = 2.0$ to $V_{CC} + 0.5V$		1	mA
I_{CC}	V_{CC} active current	$f = 5MHz$, $I_{OUT} = 0mA$, $\overline{CE} = V_{IL}$		20	mA
V_{IL}	Input low voltage		-0.6	0.8	V
V_{IH}	Input high voltage		2.0	$V_{CC} + 0.5$	V
V_{OL}	Output low voltage	$I_{OL} = 2.1mA$		0.4	V
V_{OH}	Output high voltage	$I_{OH} = -400\mu A$	2.4		V

- Notes:
- V_{CC} must be applied simultaneously with or before V_{PP} , and removed simultaneously with or after V_{PP} .
 - V_{PP} may be connected directly to V_{CC} , except during programming. The supply current would then be the sum of I_{CC} and I_{PP} .

Table 5-4. AC characteristics for read operation

 $V_{CC} = 3.0V$ to $3.6V$ and $4.5V$ to $5.5V$

Symbol	Parameter	Condition	Atmel AT27LV256A		Units
			-90		
			Min	Max	
$t_{ACC}^{(3)}$	Address to output delay	$\overline{CE} = \overline{OE} = V_{IL}$		90	ns
$t_{CE}^{(2)}$	\overline{CE} to output delay	$\overline{OE} = V_{IL}$		90	ns
$t_{OE}^{(2)(3)}$	\overline{OE} to output delay	$\overline{CE} = V_{IL}$		50	ns
$t_{DF}^{(4)(5)}$	\overline{OE} or \overline{CE} high to output float, whichever occurred first			40	ns
t_{OH}	Output hold from address, \overline{CE} or \overline{OE} , whichever occurred first		0		ns

Figure 5-1. AC waveforms for read operation⁽¹⁾

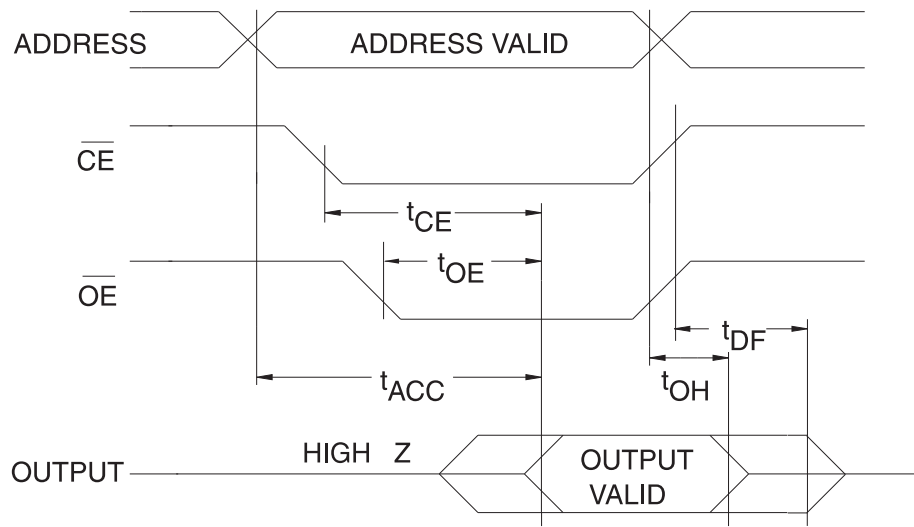

- Notes:
1. Timing measurement references are 0.8V and 2.0V. Input AC drive levels are 0.45V and 2.4V, unless otherwise specified.
 2. \overline{OE} may be delayed up to $t_{CE} - t_{OE}$ after the falling edge of \overline{CE} without impact on t_{CE} .
 3. \overline{OE} may be delayed up to $t_{ACC} - t_{OE}$ after the address is valid without impact on t_{ACC} .
 4. This parameter is only sampled, and is not 100% tested.
 5. Output float is defined as the point when data is no longer driven.

Figure 5-2. Input test waveforms and measurement levels

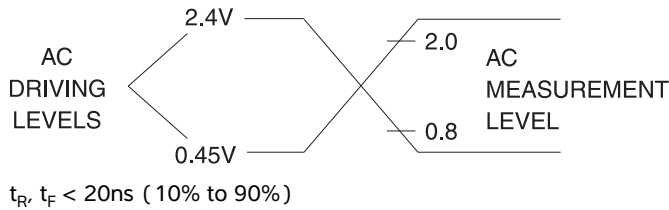
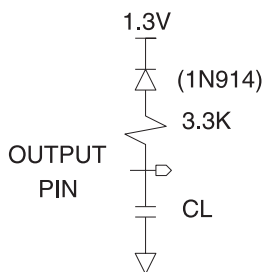

Figure 5-3. Output test load



Note: CL = 100pF including jig capacitance.

Table 5-5. Pin capacitance

$f = 1\text{MHz}$, $T = 25^\circ\text{C}$ ⁽¹⁾

Symbol	Typ	Max	Units	Conditions
C_{IN}	4	8	pF	$V_{\text{IN}} = 0\text{V}$
C_{OUT}	8	12	pF	$V_{\text{OUT}} = 0\text{V}$

Note: 1. Typical values for nominal supply voltage. This parameter is only sampled and is not 100% tested.

Figure 5-4. Programming waveforms⁽¹⁾

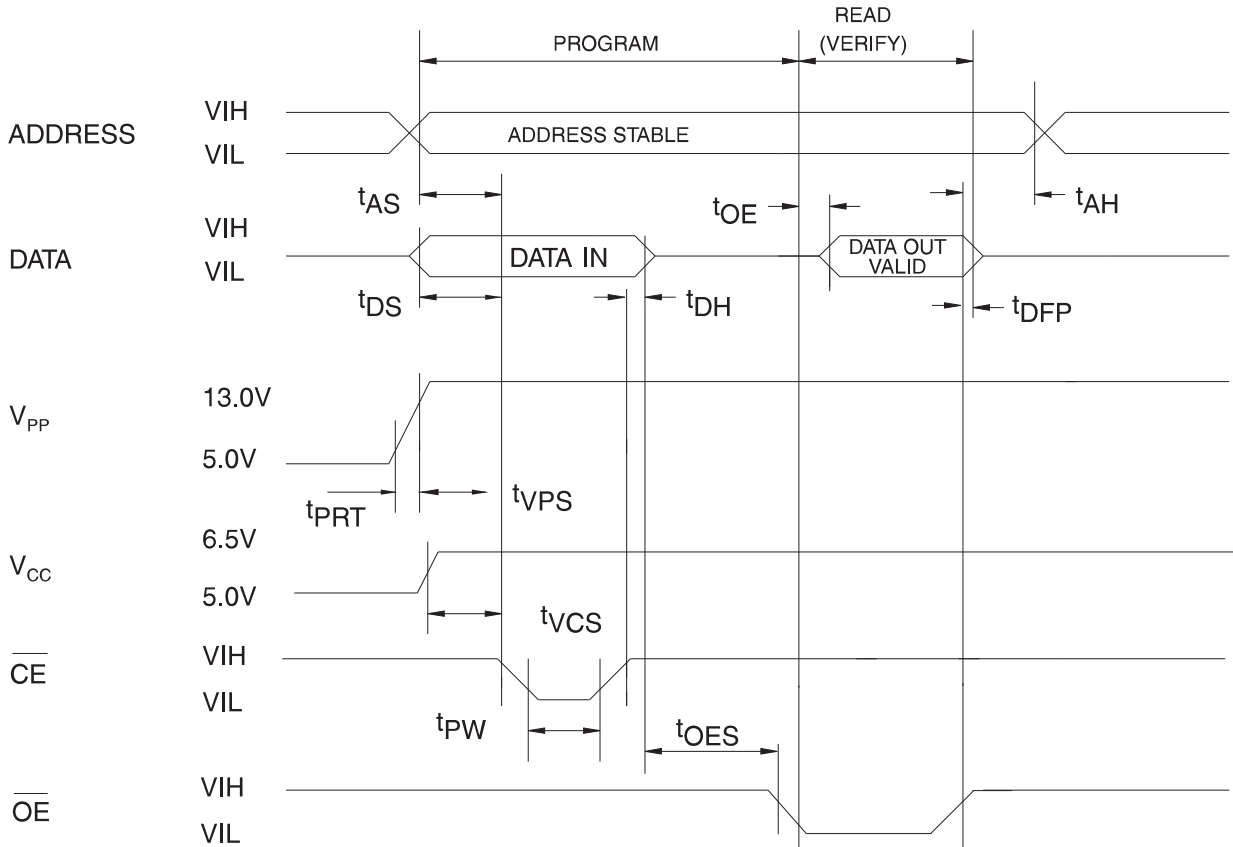

- Notes:
1. The input timing reference is 0.8V for V_{IL} and 2.0V for V_{IH} .
 2. t_{OE} and t_{DFP} are characteristics of the device, but must be accommodated by the programmer.
 3. When programming the Atmel AT27LV256A, a 0.1 μF capacitor is required across V_{PP} and ground to suppress spurious voltage transients.

Table 5-6. DC programming characteristics

 $T_A = 25 \pm 5^\circ\text{C}$, $V_{CC} = 6.5 \pm 0.25\text{V}$, $V_{PP} = 13.0 \pm 0.25\text{V}$

Symbol	Parameter	Test conditions	Limits		Units
			Min	Max	
I_{LI}	Input load current	$V_{IN} = V_{IL}, V_{IH}$		± 10	μA
V_{IL}	Input low level		-0.6	0.8	V
V_{IH}	Input high level		2.0	$V_{CC} + 0.5$	V
V_{OL}	Output low voltage	$I_{OL} = 2.1\text{mA}$		0.4	V
V_{OH}	Output high voltage	$I_{OH} = -400\mu\text{A}$	2.4		V
I_{CC2}	V_{CC} supply current (program and verify)			25	mA
I_{PP2}	V_{PP} current	$\overline{CE} = V_{IL}$		25	mA
V_{ID}	A9 product identification voltage		11.5	12.5	V

Table 5-7. AC programming characteristics

 $T_A = 25 \pm 5^\circ\text{C}$, $V_{CC} = 6.5 \pm 0.25\text{V}$, $V_{PP} = 13.0 \pm 0.25\text{V}$

Symbol	Parameter	Test conditions ⁽¹⁾	Limits		Units
			Min	Max	
t_{AS}	Address setup time	Input rise and fall times (10% to 90%) 20ns	2		μs
t_{OES}	\overline{OE} setup time		2		μs
t_{DS}	Data setup time		2		μs
t_{AH}	Address hold time	Input pulse levels 0.45V to 2.4V	0		μs
t_{DH}	Data hold time		2		μs
t_{DFP}	\overline{OE} high to output float delay ⁽²⁾		0	130	ns
t_{VPS}	V_{PP} setup time	Input timing reference level 0.8V to 2.0V	2		μs
t_{VCS}	V_{CC} setup time		2		μs
t_{PW}	\overline{CE} program pulse width ⁽³⁾	Output timing reference level 0.8V to 2.0V	95	105	μs
t_{OE}	Data valid from \overline{OE} ⁽²⁾			150	ns
t_{PRT}	V_{PP} pulse rise time during programming		50		ns

- Notes:
- V_{CC} must be applied simultaneously with or before V_{PP} and removed simultaneously with or after V_{PP} .
 - This parameter is only sampled, and is not 100% tested. Output float is defined as the point where data is no longer driven. See timing diagram.
 - Program pulse width tolerance is $100 \mu\text{sec} \pm 5\%$.

Table 5-8. The Atmel AT27LV256A integrated product identification code⁽¹⁾

Codes	Pins									Hex data
	A0	O7	O6	O5	O4	O3	O2	O1	O0	
Manufacturer	0	0	0	0	1	1	1	1	0	1E
Device type	1	1	0	0	0	1	1	0	0	8C

- Note:
- The Atmel AT27LV256A has the same product identification code as the Atmel AT27C256R. Both are programming compatible.

6. Rapid programming algorithm

A $100\mu\text{s}$ $\overline{\text{CE}}$ pulse width is used to program. The address is set to the first location. V_{CC} is raised to 6.5V and V_{PP} is raised to 13.0V. Each address is first programmed with one $100\mu\text{s}$ $\overline{\text{CE}}$ pulse without verification. Then a verification/reprogramming loop is executed for each address. In the event a byte fails to pass verification, up to 10 successive $100\mu\text{s}$ pulses are applied with a verification after each pulse. If the byte fails to verify after 10 pulses have been applied, the part is considered failed. After the byte verifies properly, the next address is selected until all have been checked. V_{PP} is then lowered to 5.0V and V_{CC} to 5.0V. All bytes are read again and compared with the original data to determine if the device passes or fails.

Figure 6-1. Rapid programming algorithm

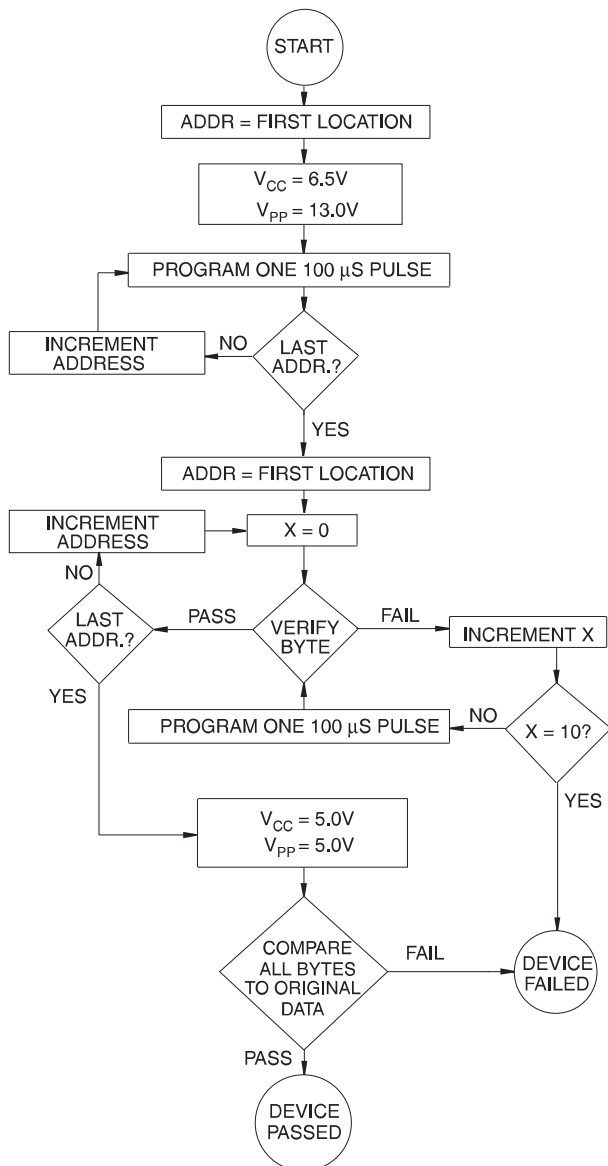

7. Ordering information

Green package option (Pb/halide-free)

t _{ACC} (ns)	I _{CC} (mA)		Atmel ordering code	Package	Lead finish	Operation range
	Active	Standby				
90	8	0.02	AT27LV256A-90JU	32J	Matte tin	Industrial (-40°C to 85°C)

Package type	
32J	32-lead, plastic, J-leaded chip carrier (PLCC)

8. Packaging information

32J – PLCC

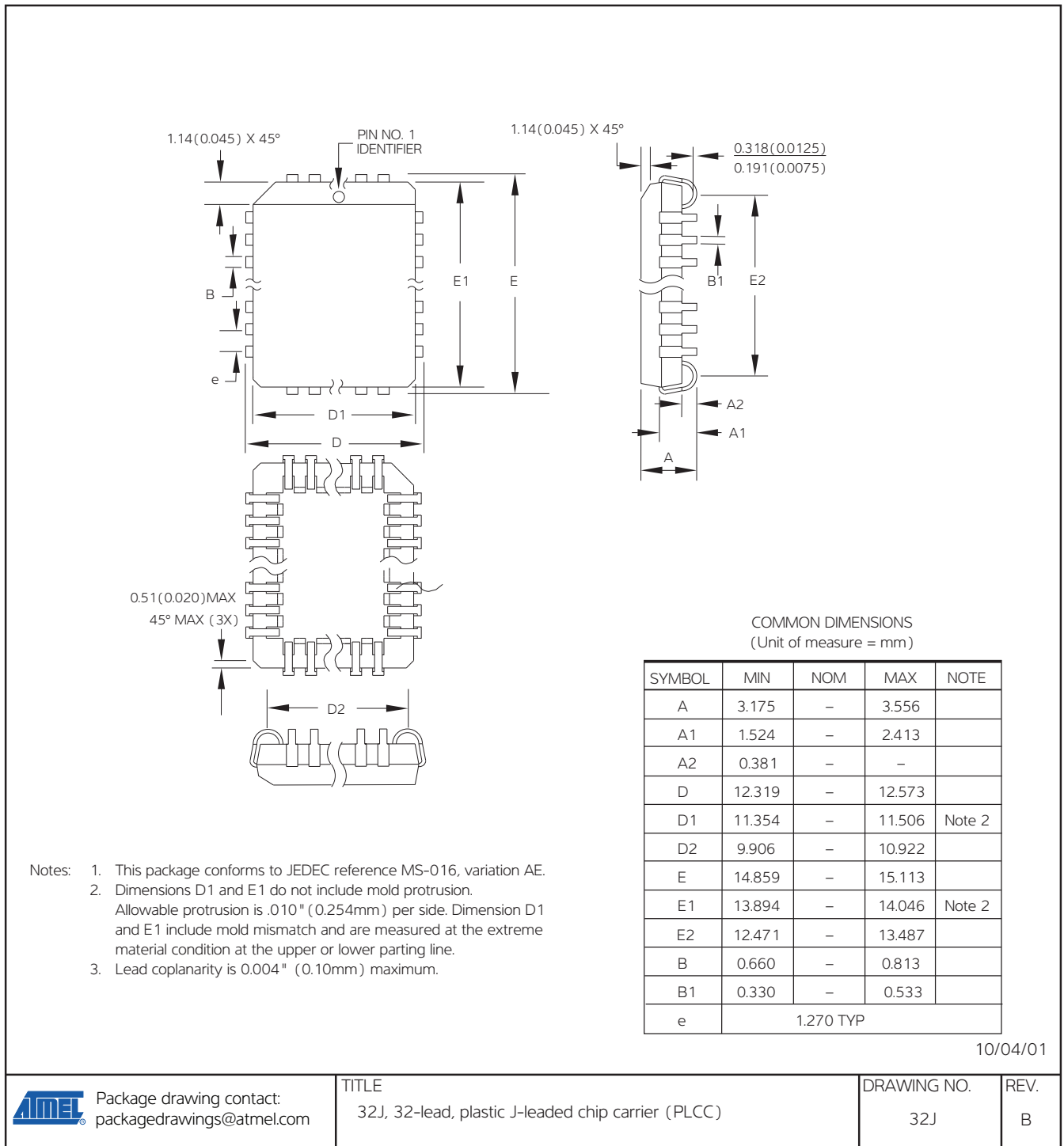

9. Revision history

Doc. rev.	Date	Comments
0547E	04/2011	Remove SOIC and TSOP packages Add lead finish to ordering information
0547D	12/2007	

**Atmel Corporation**

2325 Orchard Parkway
San Jose, CA 95131
USA

Tel: (+1) (408) 441-0311

Fax: (+1) (408) 487-2600

www.atmel.com

Atmel Asia Limited

Unit 01-5 & 16, 19F
BEA Tower, Millennium City 5
418 Kwun Tong Road

Kwun Tong, Kowloon

HONG KONG

Tel: (+852) 2245-6100

Fax: (+852) 2722-1369

Atmel Munich GmbH

Business Campus
Parkring 4
D-85748 Garching b. Munich
GERMANY

Tel: (+49) 89-31970-0

Fax: (+49) 89-3194621

Atmel Japan

9F, Tonetsu Shinkawa Bldg.
1-24-8 Shinkawa
Chuo-ku, Tokyo 104-0033
JAPAN

Tel: (+81) (3) 3523-3551

Fax: (+81) (3) 3523-7581

© 2011 Atmel Corporation. All rights reserved. / Rev.: 0547H-EPROM-4/11

Atmel®, logo and combinations thereof, and others are registered trademarks or trademarks of Atmel Corporation or its subsidiaries. Other terms and product names may be trademarks of others.

Disclaimer: The information in this document is provided in connection with Atmel products. No license, express or implied, by estoppel or otherwise, to any intellectual property right is granted by this document or in connection with the sale of Atmel products. EXCEPT AS SET FORTH IN THE ATMEL TERMS AND CONDITIONS OF SALES LOCATED ON THE ATMEL WEBSITE, ATMEL ASSUMES NO LIABILITY WHATSOEVER AND DISCLAIMS ANY EXPRESS, IMPLIED OR STATUTORY WARRANTY RELATING TO ITS PRODUCTS INCLUDING, BUT NOT LIMITED TO, THE IMPLIED WARRANTY OF MERCHANTABILITY, FITNESS FOR A PARTICULAR PURPOSE, OR NON-INFRINGEMENT. IN NO EVENT SHALL ATMEL BE LIABLE FOR ANY DIRECT, INDIRECT, CONSEQUENTIAL, PUNITIVE, SPECIAL OR INCIDENTAL DAMAGES (INCLUDING, WITHOUT LIMITATION, DAMAGES FOR LOSS AND PROFITS, BUSINESS INTERRUPTION, OR LOSS OF INFORMATION) ARISING OUT OF THE USE OR INABILITY TO USE THIS DOCUMENT, EVEN IF ATMEL HAS BEEN ADVISED OF THE POSSIBILITY OF SUCH DAMAGES. Atmel makes no representations or warranties with respect to the accuracy or completeness of the contents of this document and reserves the right to make changes to specifications and products descriptions at any time without notice. Atmel does not make any commitment to update the information contained herein. Unless specifically provided otherwise, Atmel products are not suitable for, and shall not be used in, automotive applications. Atmel products are not intended, authorized, or warranted for use as components in applications intended to support or sustain life.