

LOC F DIST 00

REVISIONS

P	LTR	DESCRIPTION	DATE	DWN	APVD
	D3	DRAWING UPDATE	14DEC2010	FSt	JDr

ARETE AVEC CHAMFREIN (PAS D'ARETE VIVE)  
EDGE WITH CHAMFER (NO SHARP EDGE)

DETAIL / DETAILED VIEW A  
ECHELLE / SCALE 32:1

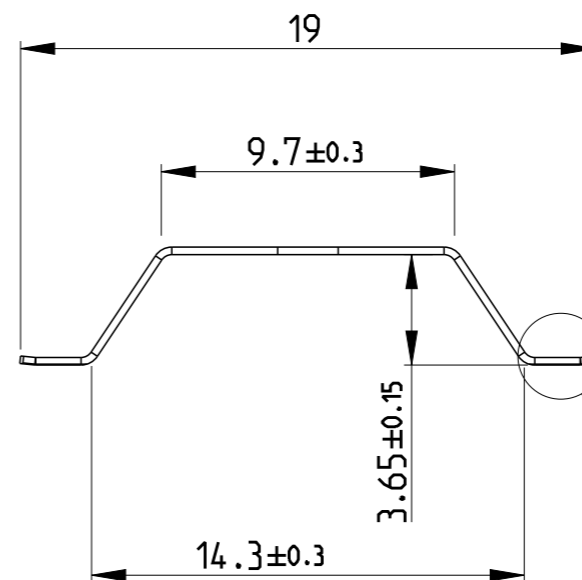
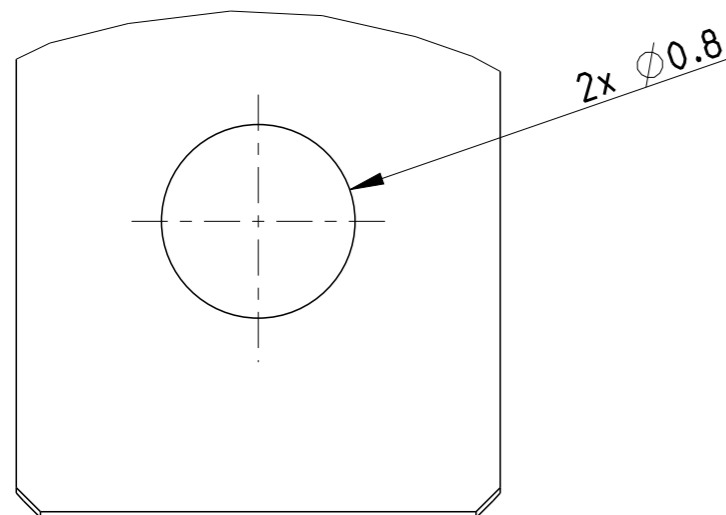
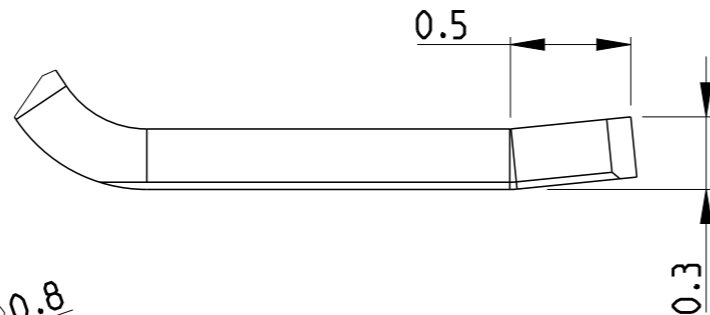
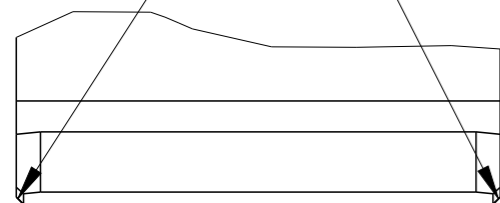

ECHELLE / SCALE 1:1

VOIR DETAIL A  
SEE DETAILED VIEW A

VOIR DETAIL B  
SEE DETAILED VIEW B

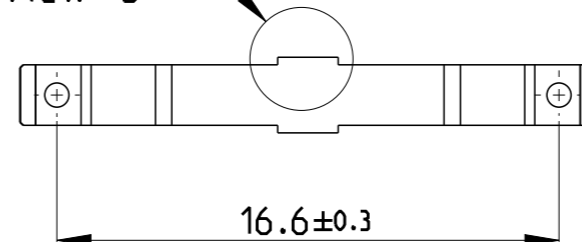

DETAIL / DETAILED VIEW B  
ECHELLE / SCALE 16:1

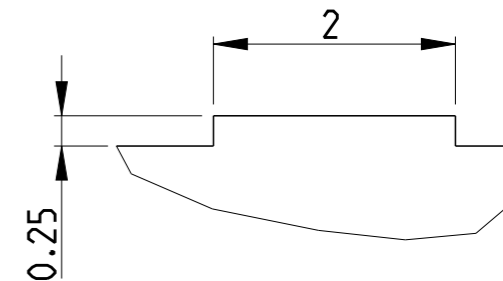

NOTE / NOTE

1	EPAISSEUR MATIERE 0.25 ±0.02 AVEC ETAMAGE	MATERIAL THICKNESS 0.25 ±0.02 PLATING INCLUDED
---	--	---

GEOMETRIE RECOMMANDEE POUR LA PASTILLE  
RECOMMENDED PAD GEOMETRY

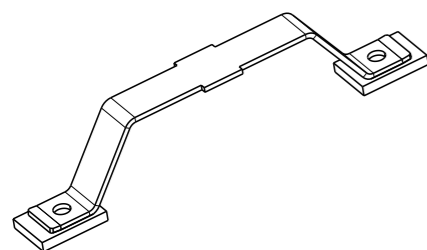

ECHELLE / SCALE 3:1

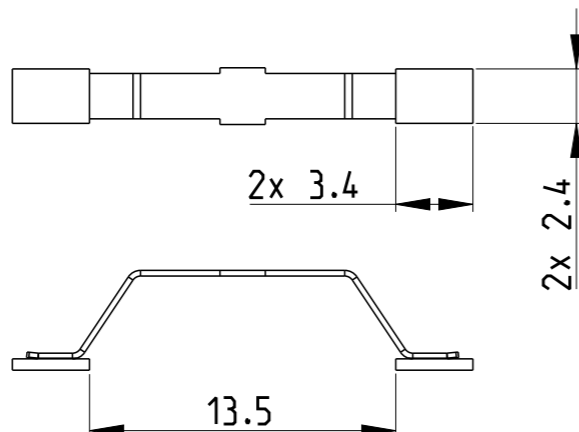

1544378-2	SHUNT CMS SMS BRIDGE	CuSn6 CuSn6	ETAMAGE 5-9 µm TINNED 5-9 µm	107-15670 (BOBINE DIA. 330MM) (REEL DIA. 330MM)
1544378-1	SHUNT CMS SMS BRIDGE	CuSn6 CuSn6		107-15670 (BOBINE DIA. 380MM) (REEL DIA. 380MM)
REF. TE TE PN	DESIGNATION DESCRIPTION	MATIERE MATERIAL	TRAITEMENT DE SURFACE PLATING	SPEC. DE CONDITIONNEMENT PACKAGING SPEC

THIS DRAWING IS A CONTROLLED DOCUMENT FOR TYCO ELECTRONICS CORPORATION  
IT IS SUBJECT TO CHANGE AND THE CONTROLLING ENGINEERING ORGANIZATION  
SHOULD BE CONTACTED FOR THE LATEST REVISION.

DWN F.SAPET 14DEC2010  
CHK P.CHARLES 14DEC2010  
APVD J.DAHER 14DEC2010

Tyco Electronics Tyco Electronics France SAS  
517 av. de la Boisse. 73000 CHAMBERY

DIMENSIONS: mm	TOLERANCES UNLESS OTHERWISE SPECIFIED:
	0 PLC ±0.2 1 PLC ±0.2 2 PLC ±0.2 3 PLC ±0.2 4 PLC ±0.2 ANGLES ±5° FINISH SEE TABLE
MATERIAL SEE TABLE	SEE TABLE

NAME SHUNT CMS  
SMS BRIDGE  
APPLICATION SPEC -  
WEIGHT -

SIZE A3	CAGE CODE 00779	DRAWING NO C-1544378	RESTRICTED TO -
---------	-----------------	----------------------	-----------------

CUSTOMER DRAWING SCALE 4:1 SHEET 1 OF 1 REV D3