

PART NO.	"A" O.D.	"B" O.D.	"C" THICK.	MATERIAL	FINISH
901-001	5/16	.147	.027	BRASS	NICKEL .00015 MIN.
901-002	.640±.010	.495±.010	.022/.045	RUBBER	BLACK

OBS.

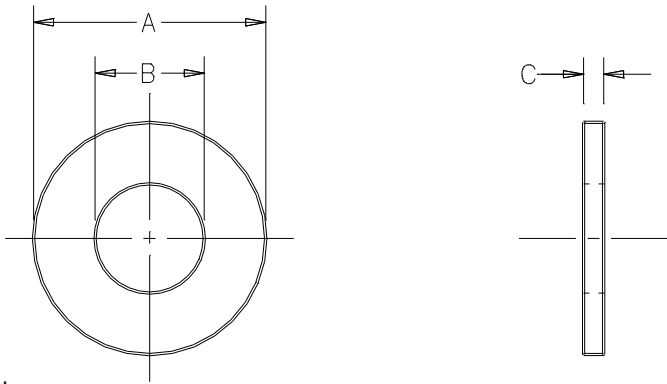

NOTES:

1. OIL RESISTANT SYNTHETIC RUBBER, 75-85 DUROMETER HARDNESS.
2. FLAT SURFACES TO BE SMOOTH & FREE OF DEPRESSIONS OR OTHER FLAWS.
3. ALL SHIPMENTS REQUIRE A CERTIFICATE OF COMPLIANCE.

NO	COMPONENT NO	DESCRIPTION	QTY/M	U/M
----	--------------	-------------	-------	-----

BILL OF MATERIAL

UNLESS OTHERWISE SPECIFIED, DIMENSIONS DO NOT INCLUDE PLATING.

O	DENOTES CRITICAL CHARACTERISTICS.
CPK	DENOTES CPK DIMENSIONS, -MINIMUM CPK VALUE
ST	DENOTES A CHARACTERISTIC THAT PROVIDES AN INDICATION OF PROCESS PERFORMANCE. PROCEDURE FOR MEASUREMENT AND TRACKING TO BE DEFINED IN LITTELFUSE INSPECTION INSTRUCTIONS.
CP	DENOTES CP DIMENSIONS, -MINIMUM CP VALUE MUST BE WITHIN THE DIMENSIONAL LIMITATIONS SHOWN ON DRAWING AND INITIALLY LOCATED TO ALLOW FOR MAXIMUM TOOL LIFE.

LTR	REVISION	CHK	APD
Z	38507C-REVISE & REDRAWN IN NEW FORMAT 7/11/97 KAM		
AA	81672C-OBS. 901-001 11/1/01 PJM		

COPIES TO	MATL SPEC	FINISH
1 9 18	DRW KAM	DATE 6/27/97 SCALE 4:1
2 10 19	CHK	DATE SUPER DRW
3 12 20	APPD	DATE RAW STK WT
4 13 21	TOLERANCE UNLESS OTHERWISE SPECIFIED	
5 14 23	TWO PLACE DEC ±.01	FRACTION
6 15 33	THREE PLACE DEC ±.005	ANGULAR
7 16 43		
8 17 53		

TITLE WASHERS

Littelfuse UNCONTROLLED DOCUMENT

REVISION **A** DRWG. NO. 901-001 THRU 901-002

DES PLAINES, ILLINOIS 60016

CAD GENERATED DRAWING - NO PENCIL CHANGES ALLOWED