

4656 ZH AC Axial Fan

119 mm axial fan with high air flow and minimum noise level. Aerodynamically shaped, all metal construction. Driven by shaded pole motor. External rotor dynamically balanced in two planes. 5 fan blades made of sheet steel directly welded to the rotor. Integrated tachometer system for speed monitoring.

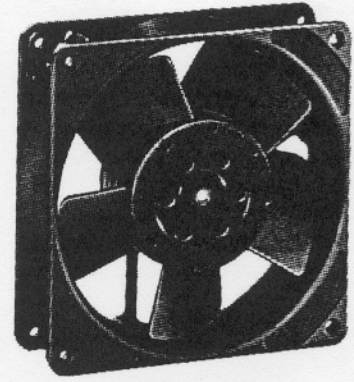

Features

- Overload protection (impedance protected).
- For maintenance-free continuous operation.
- Any mounting position.
- Type of protection IP 20 to DIN 40 050.

Tacho-Signal

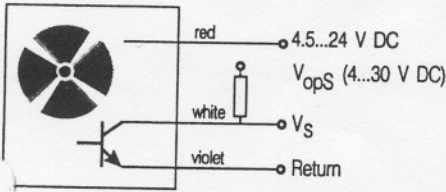

Output	1 pulses/revolution
V_S high at $I_{source} = 0$ mA	4...30 V DC (V_{opS})
V_S low at $I_{sink} = 15$ mA	≤ 0.4 V
I_{sink} max	≤ 20 mA
Pulse length	0.25...1.3 ms
Current cons. at 24 V DC	≤ 10 mA

General Data

Nominal voltage	V	230
Frequenzy	Hz	50 60
Nominal speed	min ⁻¹	2650 3100
Max. flow rate	m ³ /h	160 180
Max. flow rate	CFM	94.1 105.8
Noise free air	dB(A)	40 44
Noise in opt. operating range	bels	5.3 5.6
Power consumption	W	19 17
Perm. ambient temperature	°C	-40 ... +75 -40 ... +85
Service life at t_{max}	h	20.000 20.000
Service life at 40 °C	h	37.500 40.000
Fan housing / impeller		Metal
Bearing system		Ball bearings
Mass	kg	0.54

All data are average figures at nominal voltage.

Subject to technical change.

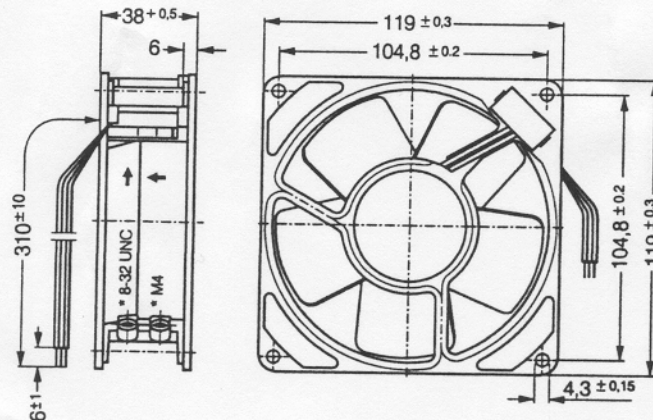
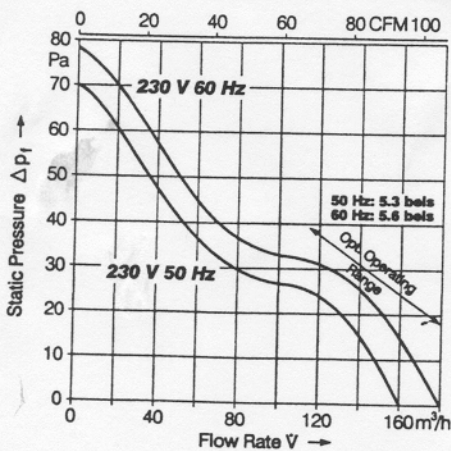

* Erdungsösen für M4 oder 8-32 UNC
Grounding lugs for M4 or 8-32 UNC

Electrical connection via 2 flat pins 2.8 x 0.5 mm for AC, 3 flying leads for tacho.