

THIS DRAWING IS UNPUBLISHED. RELEASED FOR PUBLICATION 20
 © COPYRIGHT 20 BY - ALL RIGHTS RESERVED.

REVISIONS				
P	LTR	DESCRIPTION	DATE	APVD
A		INITIAL RELEASE	24FEB2017	DW CW
A1		ECR-19-004297	21MAR2019	SR CW

TYPE 1: TWO TOP ENTRY
 类型 1: 顶部两个出线孔

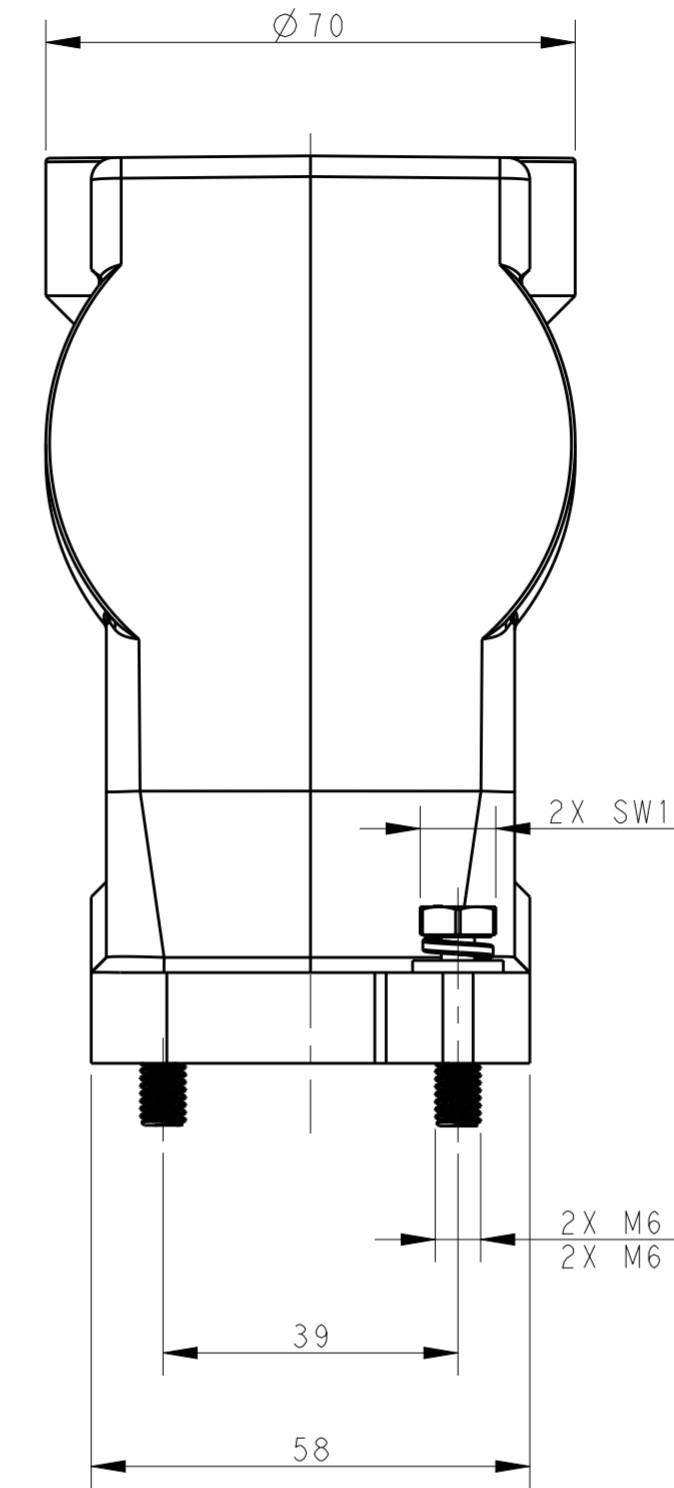
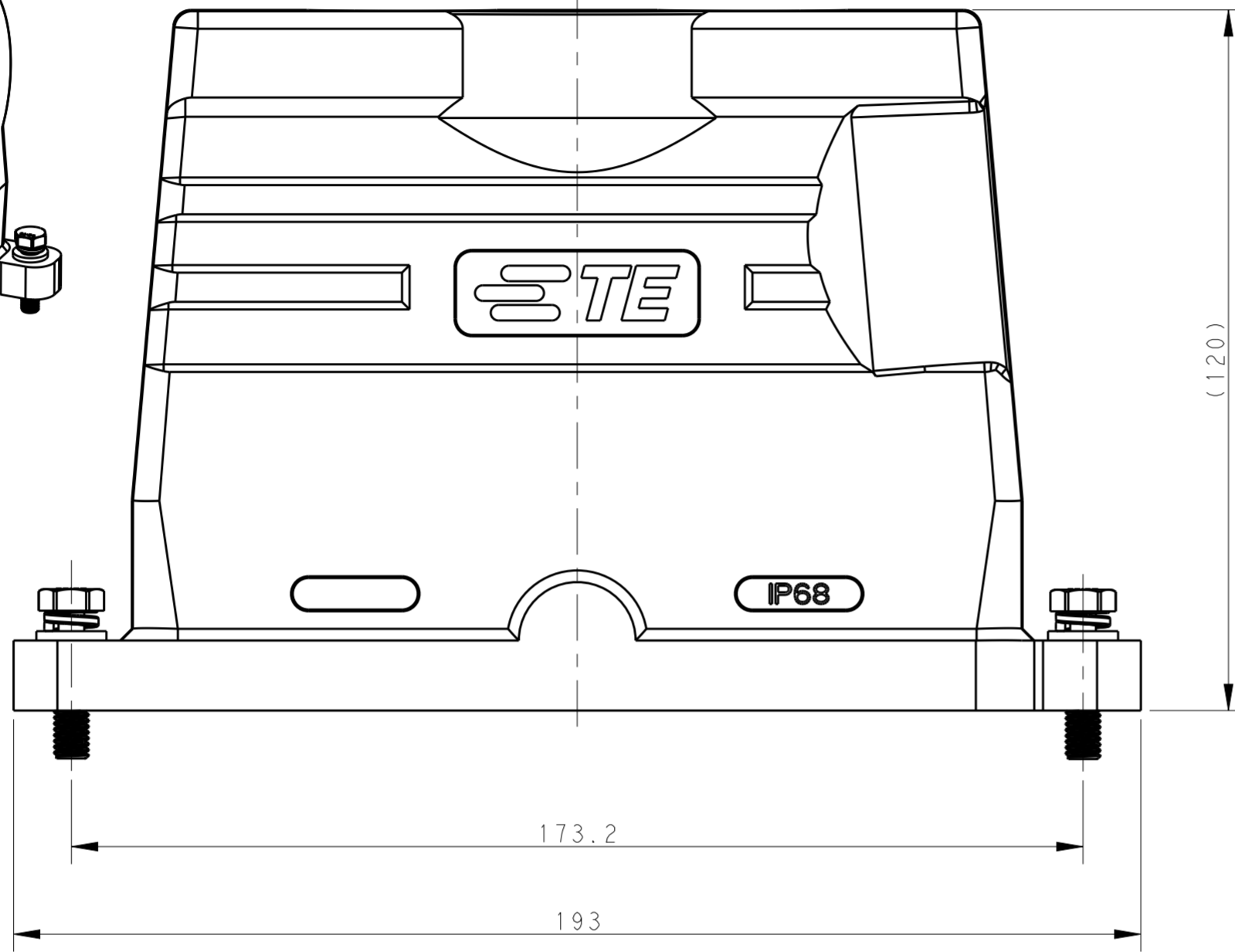
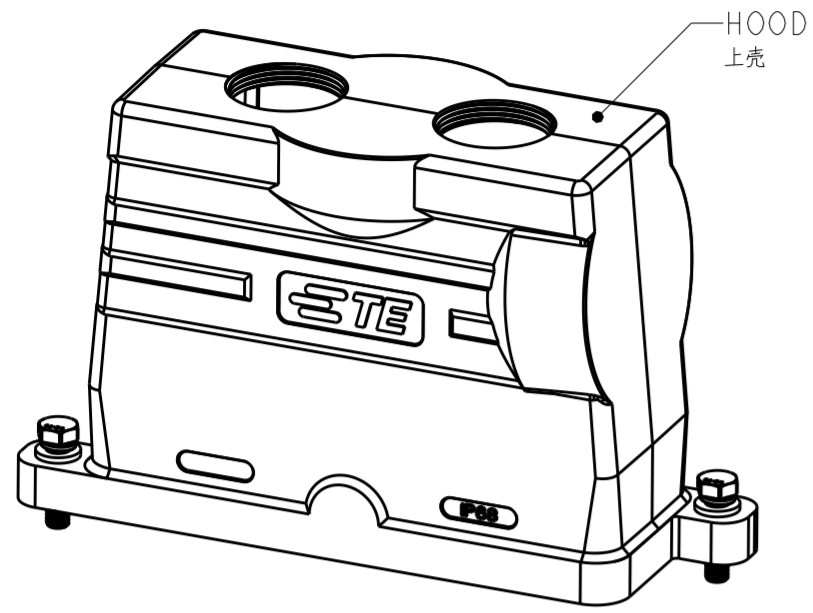

NOTES:
 1. TECHNICAL CHARACTERISTICS:
 HOOD MATERIAL: DIE CAST ALUMINIUM ALLOY
 HOOD SURFACE: POWDER COATED, BLACK
 DEGREE OF PROTECTION: IP68 (MATED)

2 OBSOLETE

注释:
 1. 技术参数:
 上壳材料: 铝合金
 上壳表面处理: 黑色粉末喷涂
 防护等级: IP68 (配合)

2 料号已停用

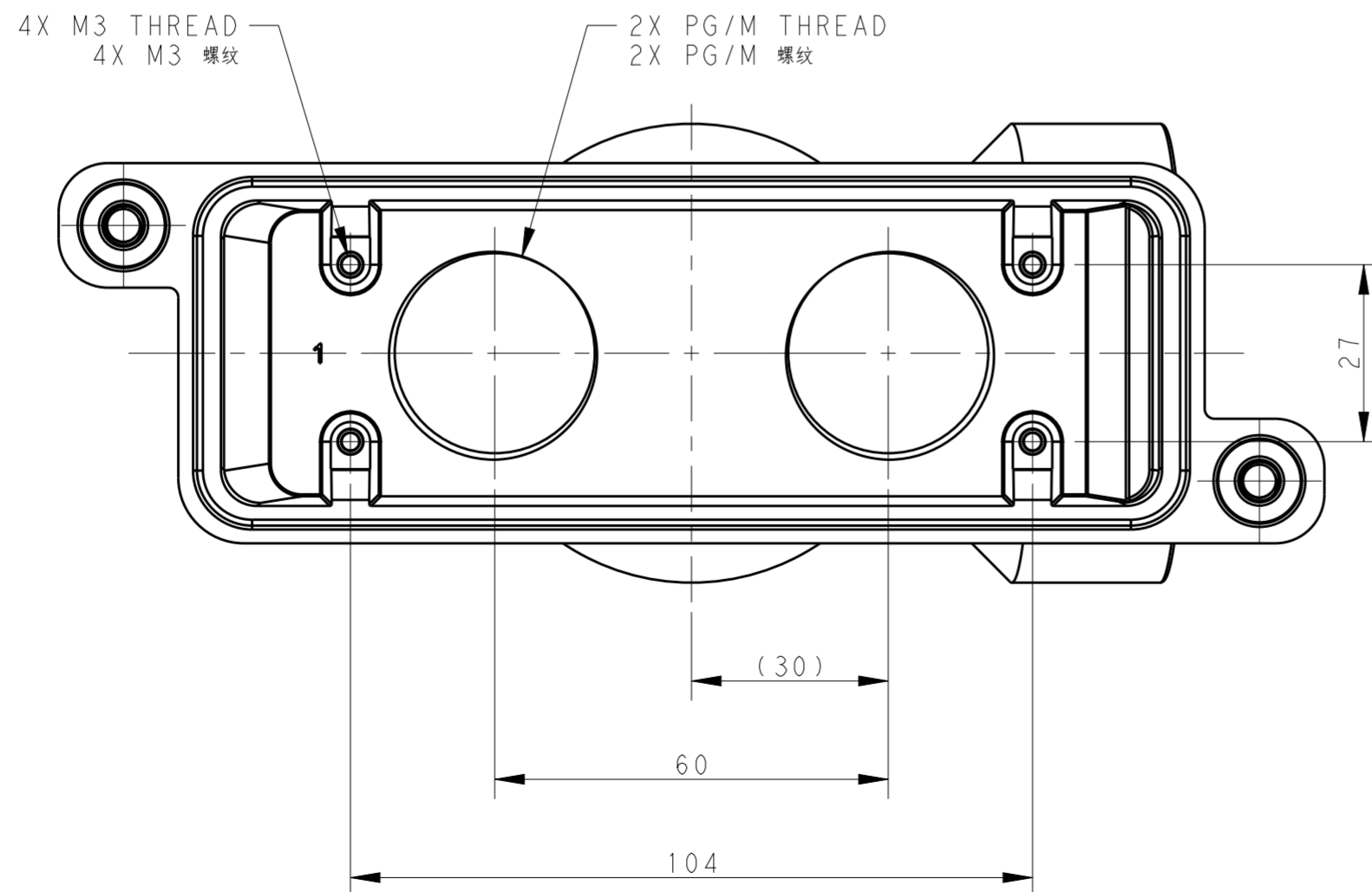

2	T1920240225-109	H24BPR-TGH-XL-2M25-EMC-C	H24BPR HEIGHTEN HOOD, DIAGONAL LOCKING, TOP ENTRY 2M25, POWDER COATED, BLACK H24BPR加高上壳, 对角锁定, 顶出2M25, 黑色粉末喷涂	M25
	T1920240232-109	H24BPR-TGH-XL-2M32-EMC-C	H24BPR HEIGHTEN HOOD, DIAGONAL LOCKING, TOP ENTRY 2M32, POWDER COATED, BLACK H24BPR加高上壳, 对角锁定, 顶出2M32, 黑色粉末喷涂	M32
2	T1920240240-109	H24BPR-TGH-XL-2M40-EMC-C	H24BPR HEIGHTEN HOOD, DIAGONAL LOCKING, TOP ENTRY 2M40, POWDER COATED, BLACK H24BPR加高上壳, 对角锁定, 顶出2M40, 黑色粉末喷涂	M40
PART NUMBER 料号		PART DESCRIPTION 描述		2X PG/M THREAD 2X PG/M 螺纹孔

THIS DRAWING IS A CONTROLLED DOCUMENT.		DWN 24FEB2017 DAVID WANG	TE Connectivity	
		CHK 24FEB2017 CHRIS WANG		
DIMENSIONS: mm		APVD 24FEB2017 XIANG XU	NAME H24BPR-TGH-XL-XMXX-EMC-C	
TOLERANCES UNLESS OTHERWISE SPECIFIED:		PRODUCT SPEC 108-137191	SIZE A2	
0 PLC ±		APPLICATION SPEC 114-137191	CAGE CODE -	
1 PLC ±		WEIGHT -	DRAWING NO G-T1920240XXX109	
2 PLC ±		RESTRICTED TO -		
3 PLC ±		SCALE 1:1		
4 PLC ±		SHEET 1 OF 3		
ANGLES ±		REV A1		
FINISH -		CUSTOMER DRAWING		

THIS DRAWING IS UNPUBLISHED. RELEASED FOR PUBLICATION 20
 © COPYRIGHT 20 BY - ALL RIGHTS RESERVED.

REVISIONS				
P	LTR	DESCRIPTION	DATE	APVD
-	-	SEE SHEET 1	-	-

TYPE 2: THREE TOP ENTRY
 类型2: 顶部三个出线孔

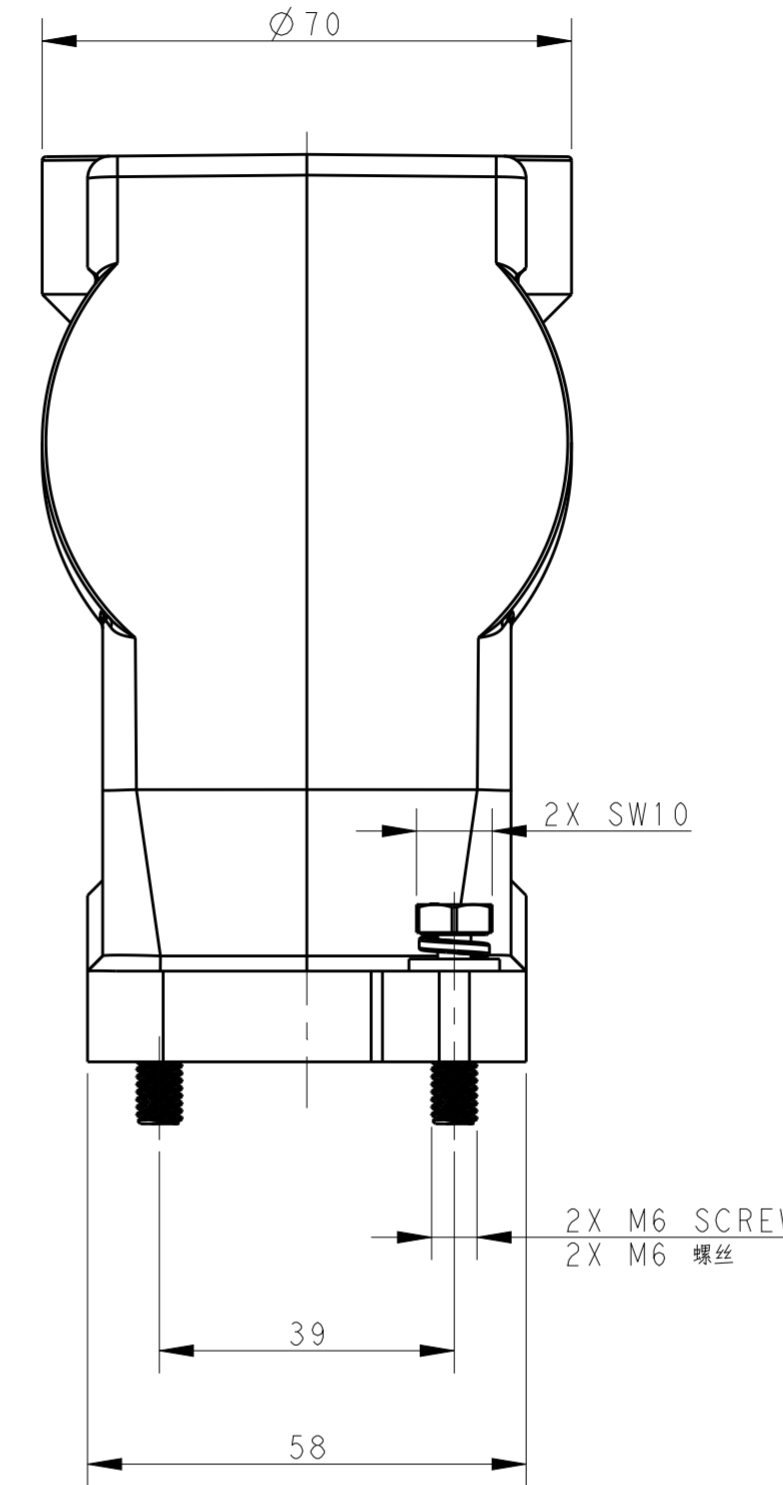
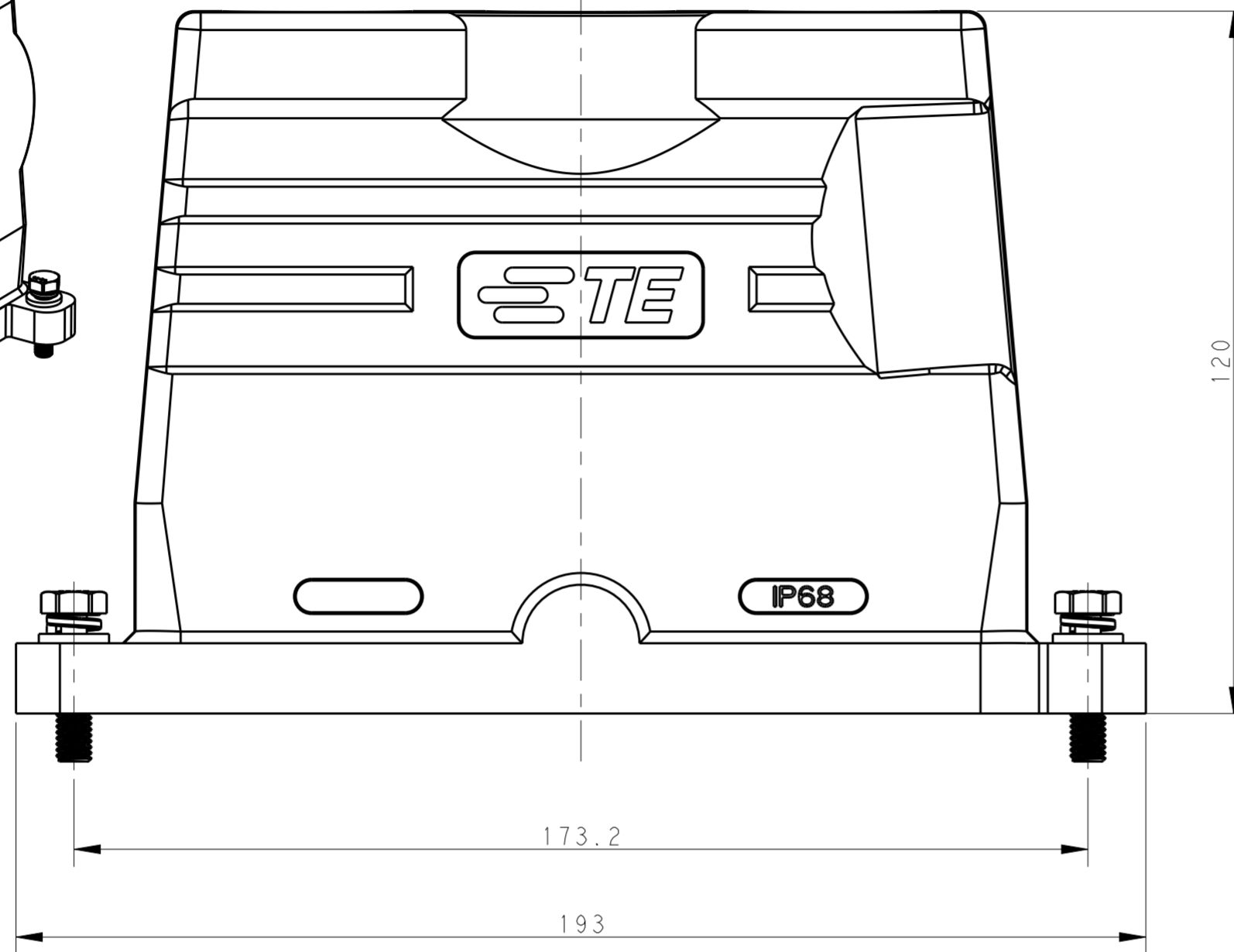
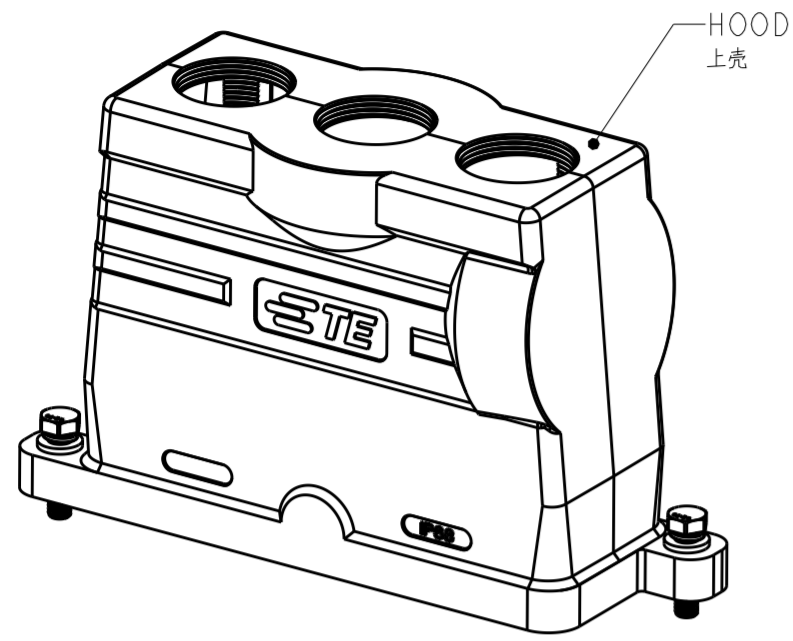

NOTE:
SEE SHEET 1

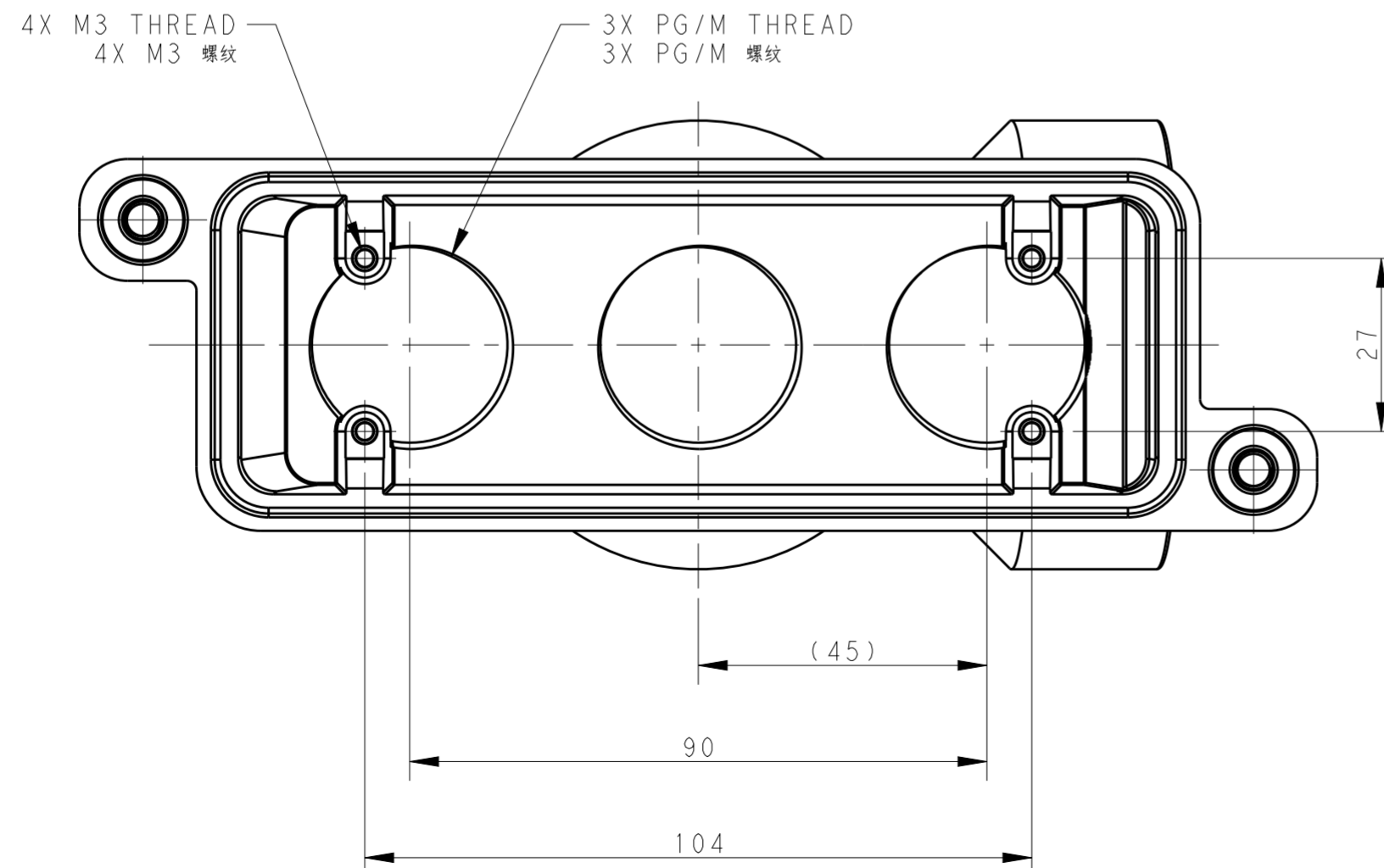

2	T1920240325-109	H24BPR-TGH-XL-3M25-EMC-C	H24BPR HEIGHTEN HOOD, DIAGONAL LOCKING, TOP ENTRY 3M25, POWDER COATED, BLACK H24BPR 加高上壳, 对角锁定, 顶出3M25, 黑色粉末喷涂	M25
2	T1920240332-109	H24BPR-TGH-XL-3M32-EMC-C	H24BPR HEIGHTEN HOOD, DIAGONAL LOCKING, TOP ENTRY 3M32, POWDER COATED, BLACK H24BPR 加高上壳, 对角锁定, 顶出3M32, 黑色粉末喷涂	M32
PART NUMBER		PART DESCRIPTION		3X PG/M THREAD
料号		描述		3X PG/M 螺纹孔

THIS DRAWING IS A CONTROLLED DOCUMENT.		DWN 24FEB2017 DAVID WANG	TE Connectivity	
		CHK 24FEB2017 CHRIS WANG		
		APVD 24FEB2017 XIANG XU	NAME H24BPR-TGH-XL-XMXX-EMC-C	
DIMENSIONS: mm		PRODUCT SPEC 108-137191	SIZE A2	
TOLERANCES UNLESS OTHERWISE SPECIFIED:		APPLICATION SPEC 114-137191	CAGE CODE -	
0 PLC ±		WEIGHT -	DRAWING NO. C-T1920240XXX109	
1 PLC ±		RESTRICTED TO -		
2 PLC ±		SCALE 1:1		
3 PLC ±		SHEET 2 OF 3		
4 PLC ±		REV A1		
ANGLES ±		CUSTOMER DRAWING		
FINISH -				

THIS DRAWING IS UNPUBLISHED. RELEASED FOR PUBLICATION 20
 © COPYRIGHT 20 BY - ALL RIGHTS RESERVED.

REVISIONS				
P	LTR	DESCRIPTION	DATE	APVD
-	-	SEE SHEET 1	-	-

TYPE 3: FOUR TOP ENTRY
 类型3: 顶部四个出线孔

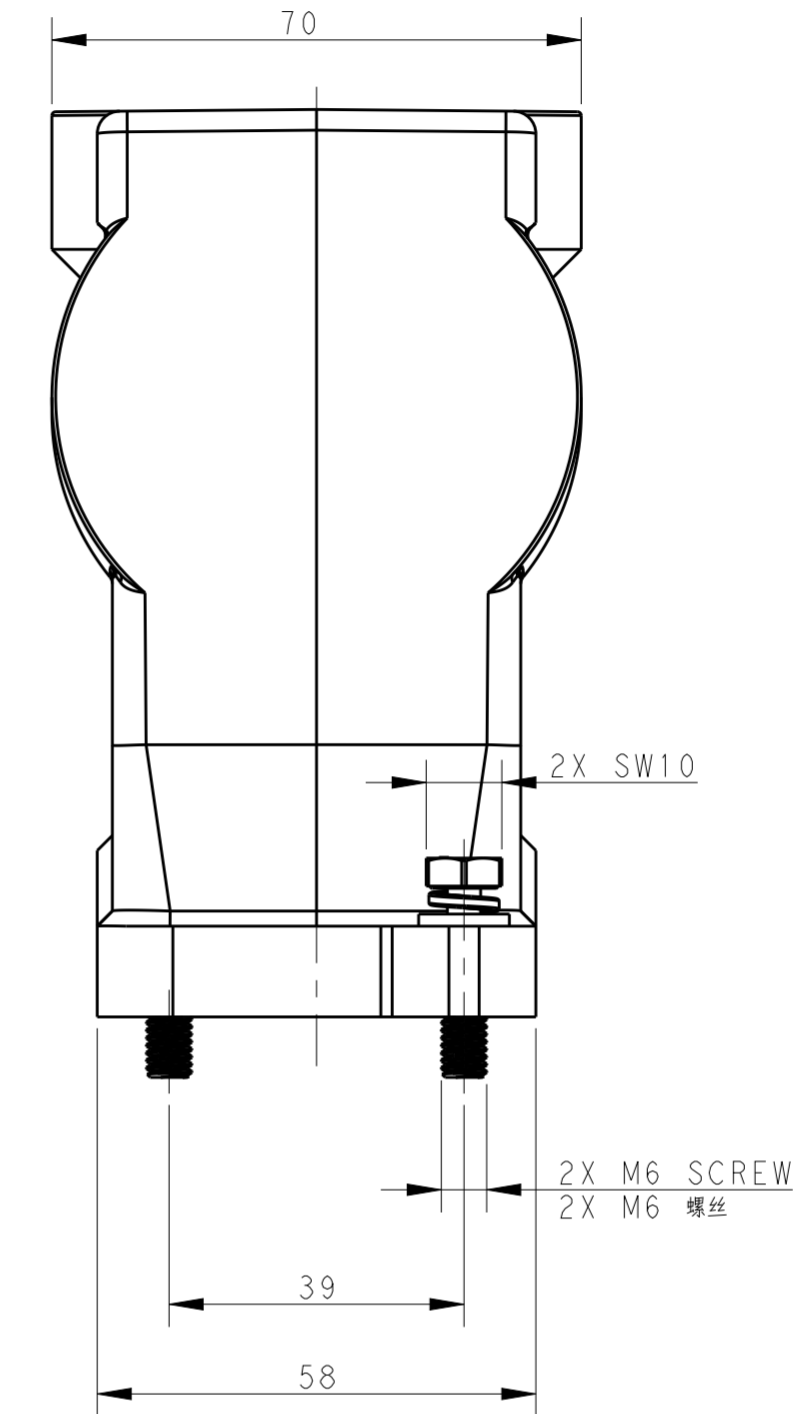
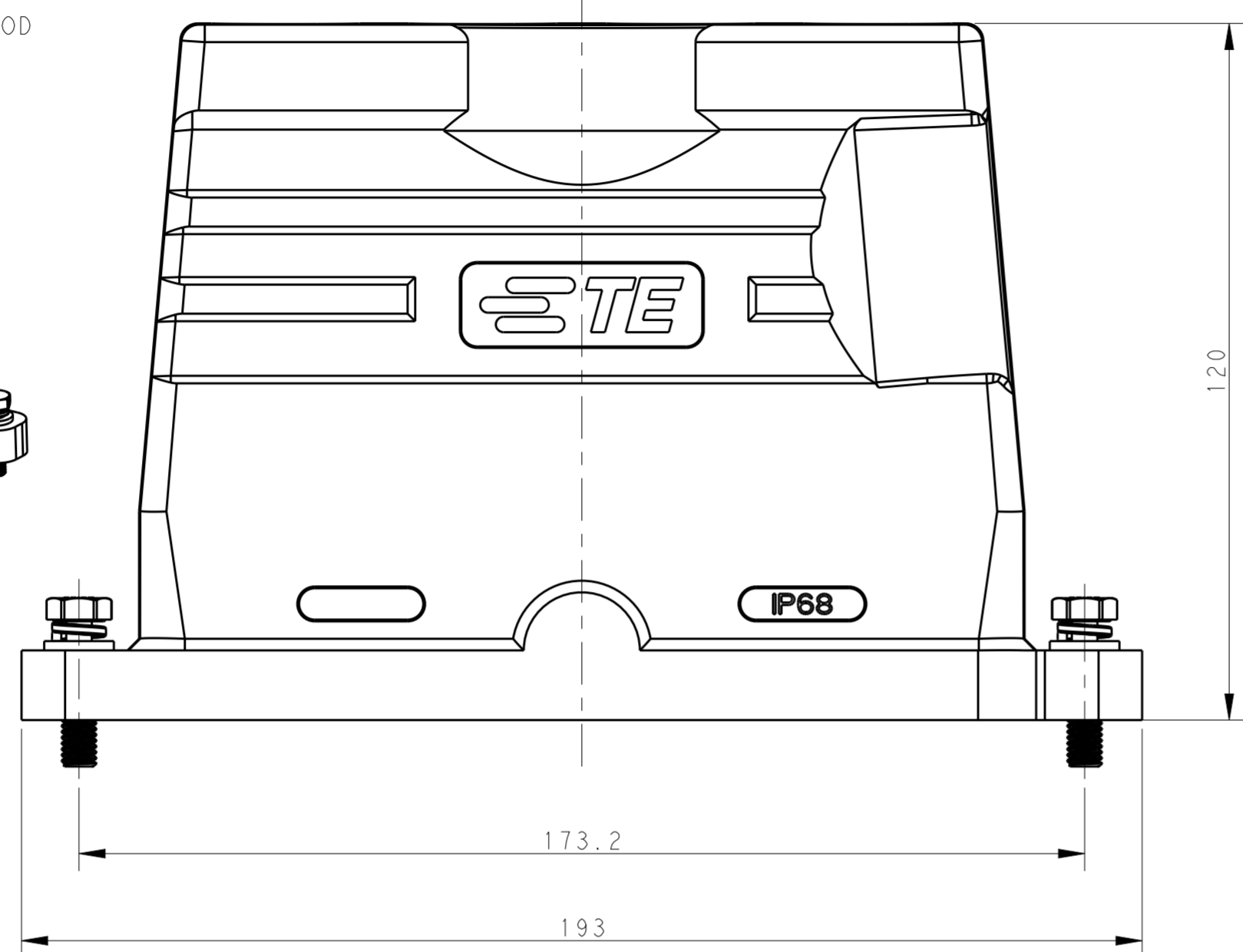
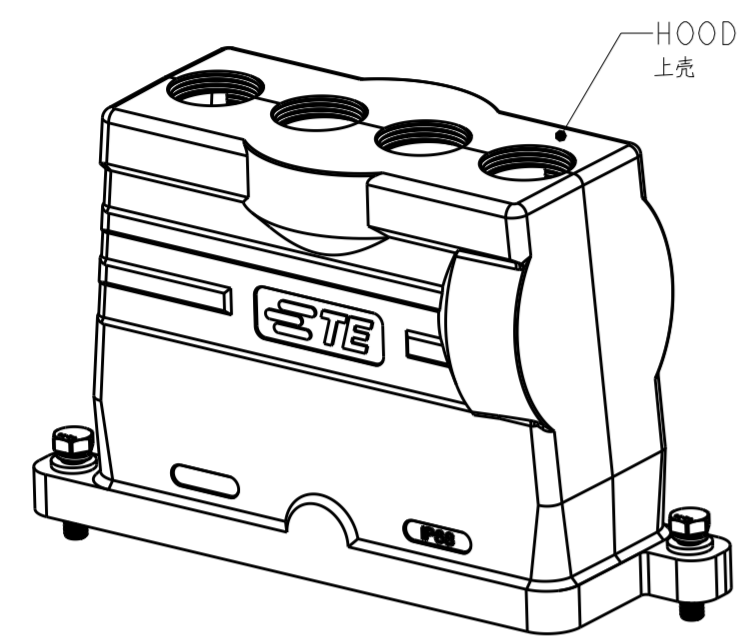

NOTE:
SEE SHEET 1

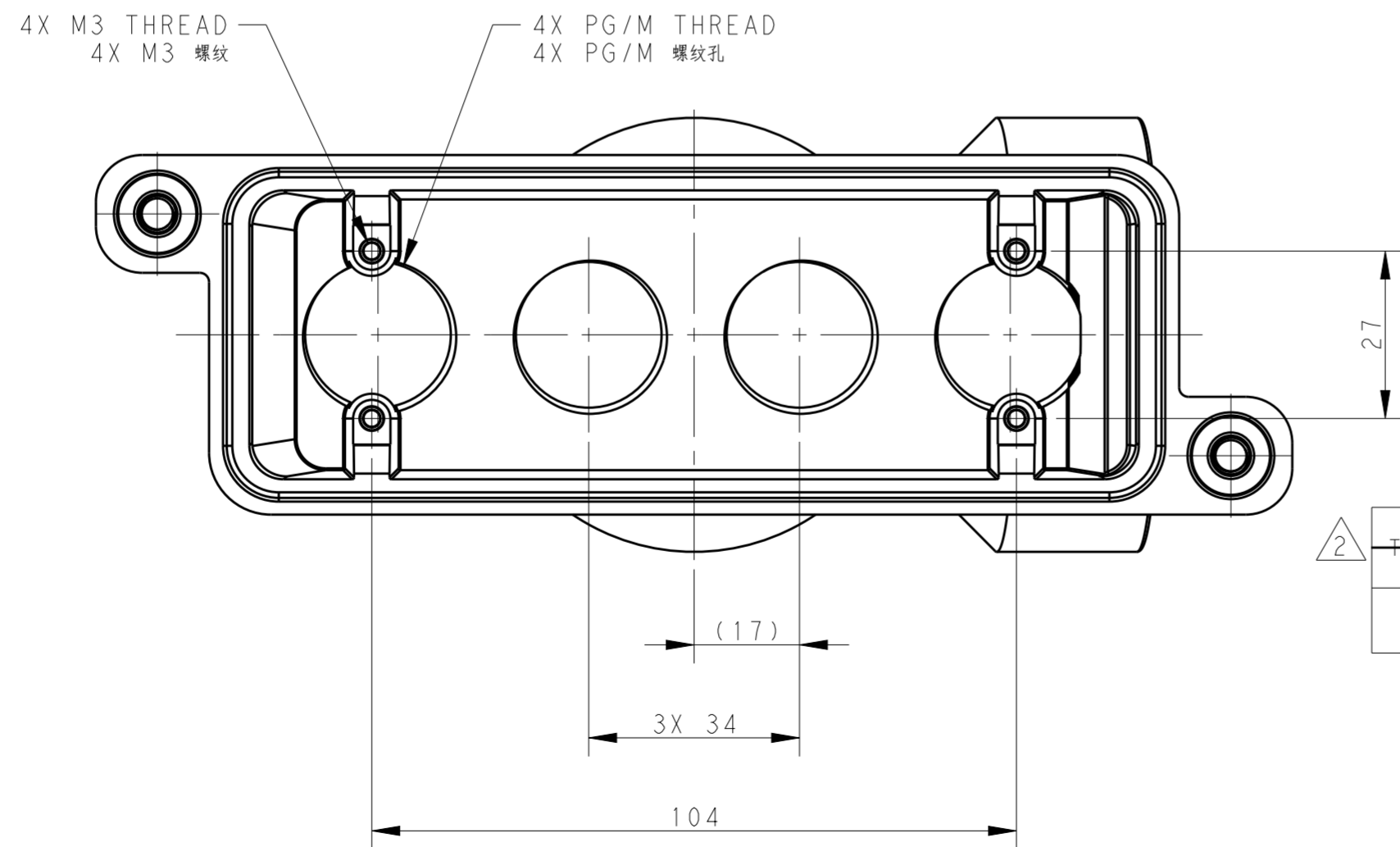

T1920240425 109	H24BPR TGH XL 4M25 EMC C	H24BPR HEIGHTEN HOOD, DIAGONAL LOCKING, TOP ENTRY 4M25, POWDER COATED, BLACK H24BPR 加高上壳, 对角锁定, 顶出4M25, 黑色粉末喷涂	M25
PART NUMBER 料号	PART DESCRIPTION 描述		4X PG/M THREAD 4X PG/M 螺纹孔

THIS DRAWING IS A CONTROLLED DOCUMENT.		DWN 24FEB2017 DAVID WANG	STE TE Connectivity	
		CHK 24FEB2017 CHRIS WANG		
DIMENSIONS: mm		APVD 24FEB2017 XIANG XU	NAME H24BPR-TGH-XL-XMXX-EMC-C	
TOLERANCES UNLESS OTHERWISE SPECIFIED:		PRODUCT SPEC 108-137191	SIZE A2	
0 PLC ±		APPLICATION SPEC 114-137191	CAGE CODE -	
1 PLC ±		WEIGHT -	DRAWING NO. C-T1920240XXX109	
2 PLC ±		CUSTOMER DRAWING	RESTRICTED TO -	
3 PLC ±		SCALE 1:1	SHEET 3 OF 3	
4 PLC ±			REV A1	
ANGLES ±				
FINISH -				