

THIS DOCUMENT IS THE PROPERTY OF KEYSTONE ELECTRONICS CORP. AND SHALL NOT BE REPRODUCED, DISTRIBUTED OR USED AS A BASIS FOR MANUFACTURE WITHOUT PRIOR WRITTEN PERMISSION FROM KEYSTONE ELECTRONICS CORP.

REQUIRED SPACING FOR 'AA' CLIP

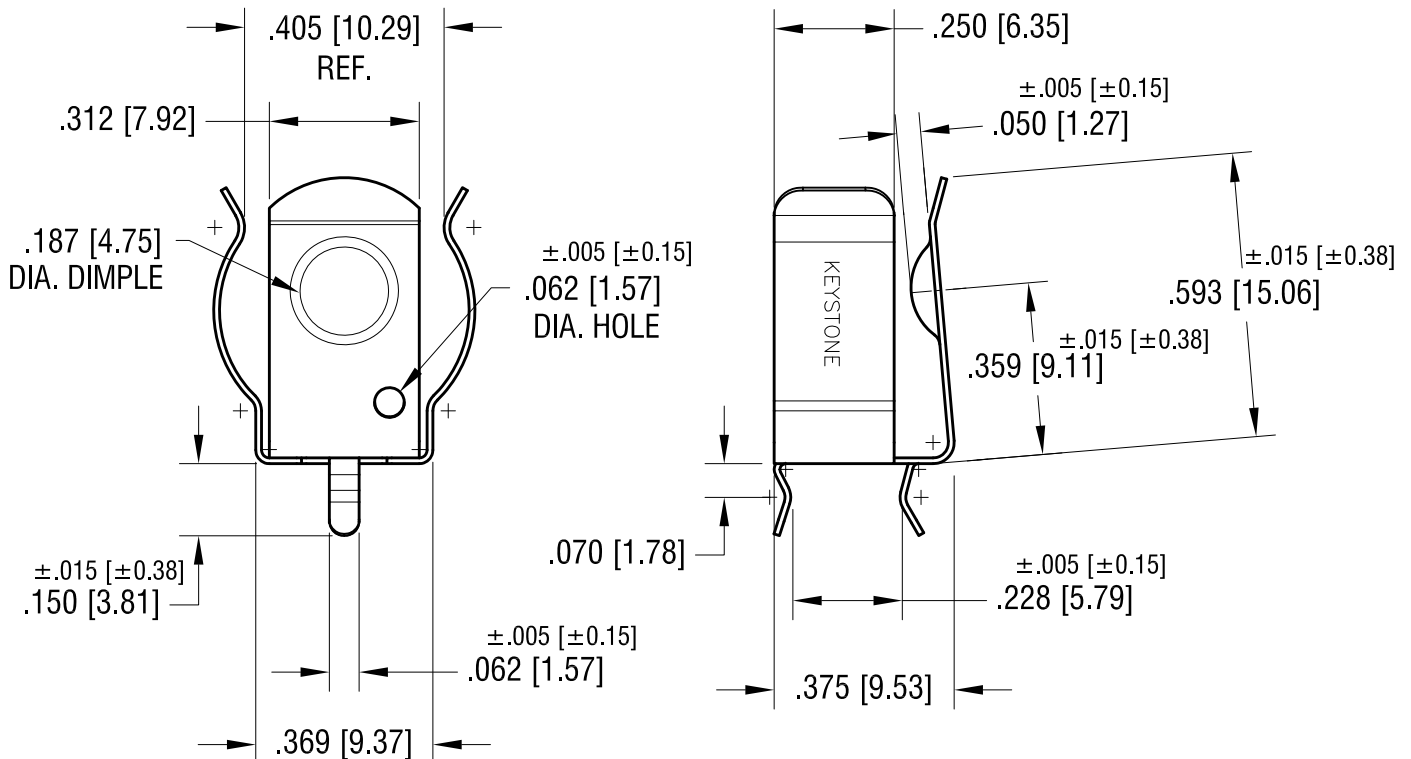
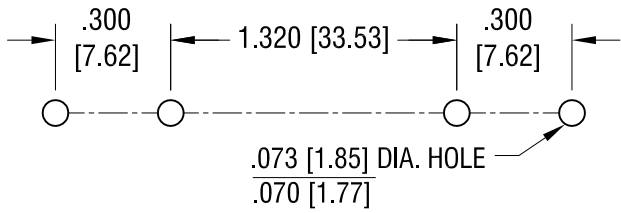

NOTE:

- 1. HEAT TREAT TO SPRING TEMPER.

DATE	DESCRIPTION	REV.
9.06.16	CHANGE AS PER ECR 16-065	N
9.01.16	CHANGE AS PER ECN16-083	M
7.11.14	CHANGE AS PER ECN14-065	L
6.19.06	CHANGE AS PER ECN 06-038	K

KEYSTONE ELECTRONICS CORP.			
www.keyelco.com • ASTORIA, N.Y. 11105-2017 • Tel (718) 956-8900			
PART NAME		'A' & 'AA' PC BATTERY CLIP	
MATERIAL		.012 [.30] TH'K ANNEALED SPRING STEEL	
FINISH		DRN BY	DATE
TIN NICKEL PLATE		BOONE	4.26.89
		APP'D	SCALE
		LN	2.5X
TOLERANCES	INCH [MM]	CODE	DWG NO.
DECIMAL	±.010 [±0.25]	C	92
ANGULAR	± 2°		
UNLESS OTHERWISE SPECIFIED			