

REVISIONS

P	LTR	DESCRIPTION	DATE	DWN	APVD
	B	INITIAL RELEASE	12DEC2017	YC	CW

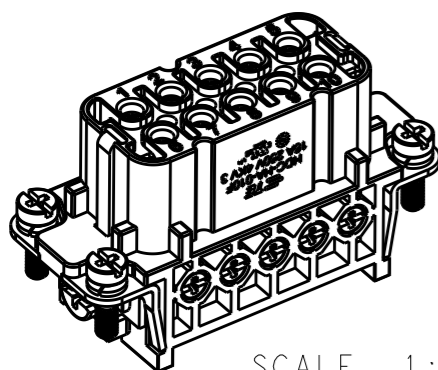

SCALE 1:1

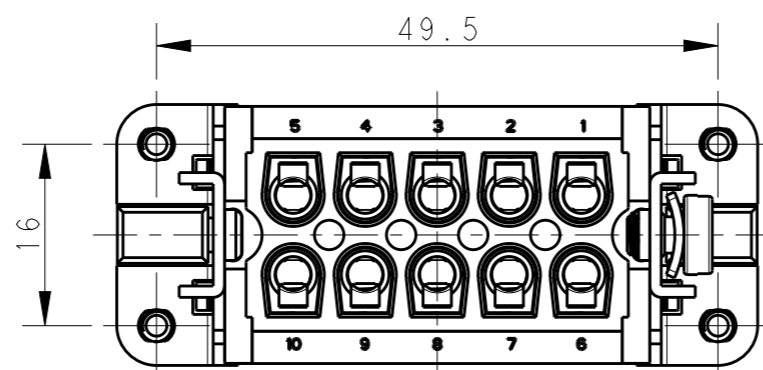

10X M3 SCREW, RECOMMENDED
TIGHTENING TORQUE 0.5N.m
10X M3 螺丝, 推荐锁紧力矩0.5N.m

M4 SCREW RECOMMENDED
TIGHTENING TORQUE 1.2N.m
M4 螺丝, 推荐锁紧力矩1.2N.m

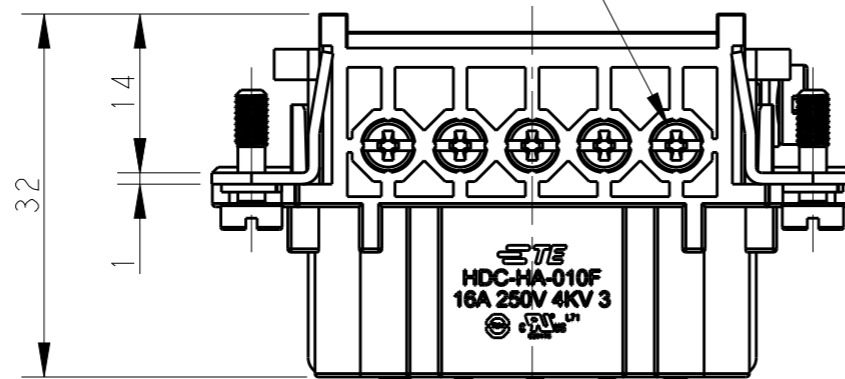

STAINLESS STEEL SCREW
不锈钢螺丝

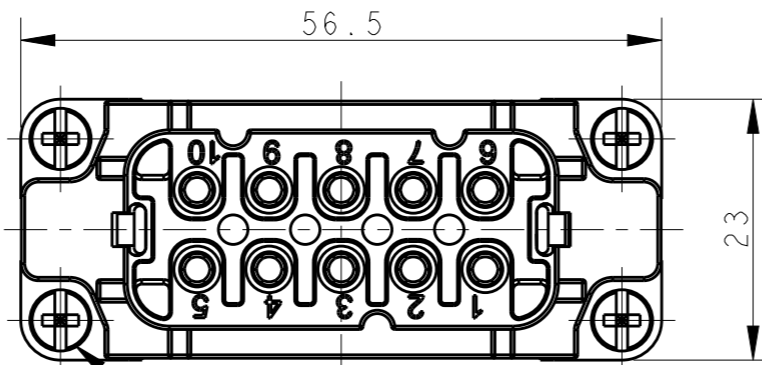

4X M3 SCREW, RECOMMENDED
TIGHTENING TORQUE 0.5N.m
4X M3螺丝, 推荐锁紧力矩0.5N.m

NOTES:

- TECHNICAL CHARACTERISTICS:
INSULATION MATERIAL: PC
RATED VOLTAGE: 250V
RATED CURRENT: 16A
INSULATION RESISTANCE: $\geq 400M\Omega$
RATED IMPULSE VOLTAGE: 4KV
POLLUTION DEGREE: 3
FLAMMABILITY: UL94V-0
MATING CYCLES: 500 CYCLES
WIRE RANGE: 0.5-2.5 mm² (20-14 AWG)
CONTACT FINISH: SILVER PLATED
CONTACT TYPE: SCREW CONTACT

注释:

- 技术参数:
绝缘材料: PC
额定电压: 250V
额定电流: 16A
绝缘电阻: $\geq 400M\Omega$
额定脉冲电压: 4KV
污染等级: 3
阻燃等级: UL94V-0
插拔次数: 500 次
接线范围: 0.5-2.5 mm² (20-14 AWG)
端子表面处理: 镀银
接线类型: 螺丝连接

PANEL CUT FOR INSERTS FOR USING
WITHOUT HOODS/ HOUSINGS
不用防护外壳时芯件的安装开孔图

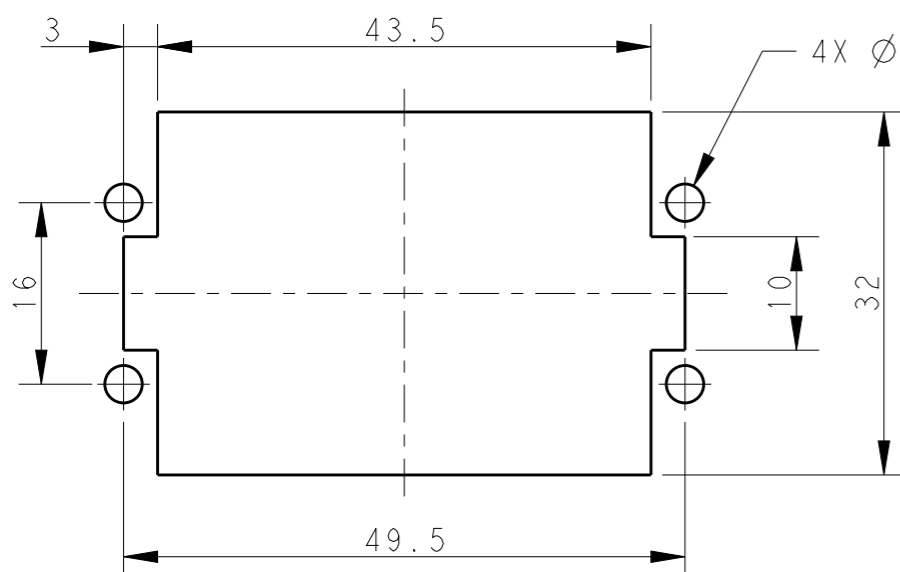

T2010102201-002	HA-010-F	HA-010 FEMALE INSERT, STAINLESS STEEL GROUNDING SCREW HA-010 母插, 不锈钢接地螺丝
PART NUMBER 料号	PART DESCRIPTION 描述	

THIS DRAWING IS A CONTROLLED DOCUMENT.		DWN 12DEC2017 YORK CHEN	 TE Connectivity	
DIMENSIONS: mm		CHK 12DEC2017 GINO YAO		
TOLERANCES UNLESS OTHERWISE SPECIFIED:		APVD 12DEC2017 CHRIS WANG	NAME HA-010-F	
0 PLC ±-		PRODUCT SPEC 108-137045	SIZE A3	
1 PLC ±-		APPLICATION SPEC 114-137045	CAGE CODE -	DRAWING NO T2010102201002
2 PLC ±-		WEIGHT -	RESTRICTED TO -	
3 PLC ±-		CUSTOMER DRAWING	SCALE 3:2	SHEET 1 OF 1
4 PLC ±-			REV B	
ANGLES ±-				
FINISH -				