

Jul.1.2019 Copyright 2019 HIROSE ELECTRIC CO., LTD. All Rights Reserved.
 In case of consideration for using Automotive equipment / device which demand high reliability, kindly contact our sales window correspondents.

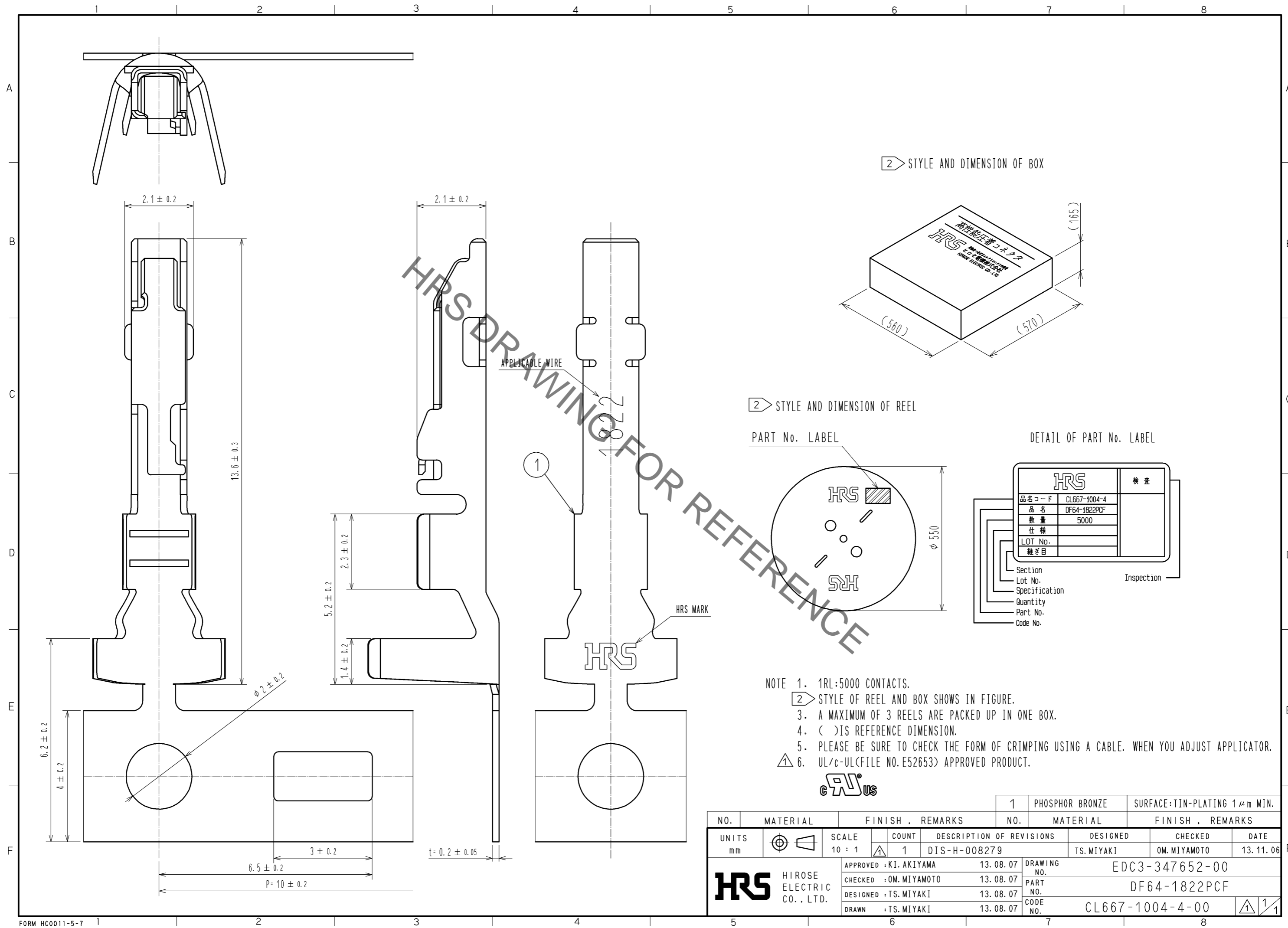

2 STYLE AND DIMENSION OF BOX

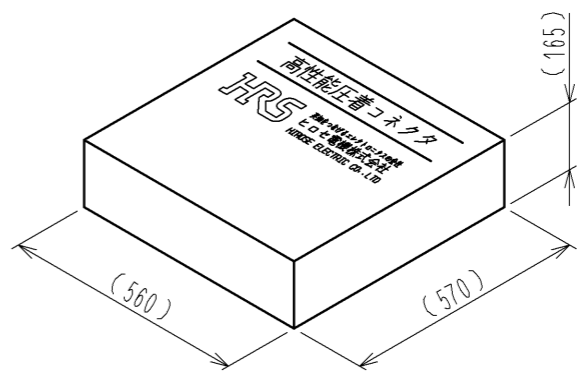

2 STYLE AND DIMENSION OF REEL

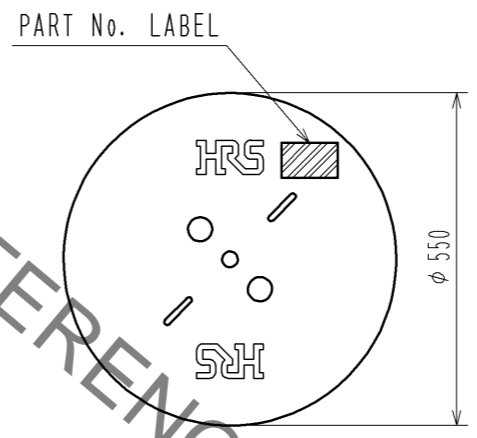

DETAIL OF PART No. LABEL

HRS		検査
品名コード	CL667-1004-4	Section Lot No. Specification Quantity Part No. Code No.
品名	DF64-1822PCF	
数量	5000	
仕様		
LOT No.		
継ぎ目		検査

- NOTE 1. 1RL:5000 CONTACTS.
 2. STYLE OF REEL AND BOX SHOWS IN FIGURE.
 3. A MAXIMUM OF 3 REELS ARE PACKED UP IN ONE BOX.
 4. () IS REFERENCE DIMENSION.
 5. PLEASE BE SURE TO CHECK THE FORM OF CRIMPING USING A CABLE. WHEN YOU ADJUST APPLICATOR.
 6. UL/c-UL(FILE NO. E52653) APPROVED PRODUCT.



NO.	MATERIAL	FINISH . REMARKS	NO.	MATERIAL	FINISH . REMARKS
			1	PHOSPHOR BRONZE	SURFACE:TIN-PLATING 1μm MIN.
UNITS mm		SCALE 10 : 1	COUNT 1	DESCRIPTION OF REVISIONS DIS-H-008279	DESIGNED TS.MIYAKI
HRS HIROSE ELECTRIC CO., LTD.		APPROVED : KI. AKIYAMA	13. 08. 07	DRAWING NO.	EDC3-347652-00
		CHECKED : OM. MIYAMOTO	13. 08. 07	PART NO.	DF64-1822PCF
		DESIGNED : TS. MIYAKI	13. 08. 07	CODE NO.	CL667-1004-4-00
		DRAWN : TS. MIYAKI	13. 08. 07		
					DATE 13. 11. 06
					CHECKED OM.MIYAMOTO