

WIDE BAND CHOKE

AWBC-09

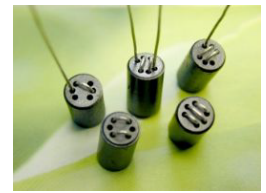

RoHS/RoHS II Compliant



Φ6.00 x 10.00mm

FEATURES:

- EMI suppression component with compact size, high impedance and medium current
- Widely used in PC products to filter EMI from the outside
- CE, FCC Compliant

APPLICATIONS:

- Computer products, motherboard, TV card
- Power supply cables, OA products, modem
- Communication equipments

Key Electrical Specifications

Operating Temperature

-40°C to +85°C

Storage Temperature

-40°C to +85°C

Impedance	Test Frequency
$\Omega \pm 25\%$	MHz
598	25
800	100

Test Conditions

Instrument: Agilent 4294A Precision Impedance Analyzer

OUTLINE DIMENSIONS:

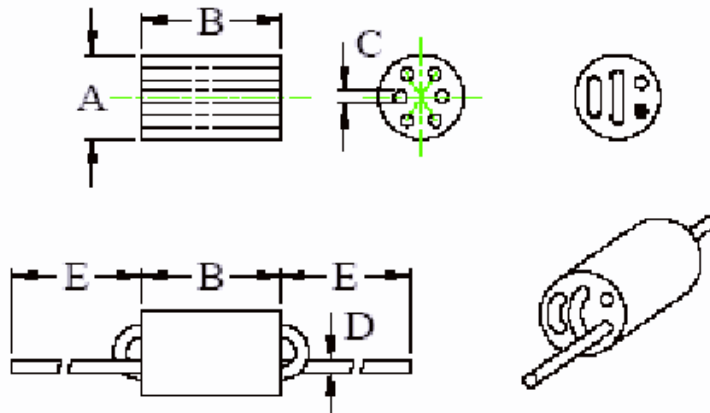

A	B	C	D	E
6.0±0.5	10.0±0.5	0.90±0.15	0.50±0.05	40.0±3.0

Dimension: mm

Packing: 1500pcs/box

ATTENTION: Abracon Corporation's products are COTS – Commercial-Off-The-Shelf products; suitable for Commercial, Industrial and, where designated, Automotive Applications. Abracon's products are not specifically designed for Military, Aviation, Aerospace, Life-dependant Medical applications or any application requiring high reliability where component failure could result in loss of life and/or property. For applications requiring high reliability and/or presenting an extreme operating environment, written consent and authorization from Abracon Corporation is required. Please contact Abracon Corporation for more information.

ABRACON IS
ISO 9001:2008
CERTIFIED



Visit www.abracon.com for Terms & Conditions of Sale
30332 Esperanza, Rancho Santa Margarita, California 92688
tel 949-546-8000 | fax 949-546-8001 | www.abracon.com

Revised: 02.24.14