

1

2

3

4

PRODUCT NUMBER  
SEE TABLE, SHT 2

Tous droits strictement reserves. Reproduction ou communication a des tiers interdite sous quelque forme que ce soit sans autorisation ecrite du proprietaire. Propriete de c FCI. Droits de reproduction FCI.



All rights strictly reserved. Reproduction or issue to third parties in any form whatever is not permitted without written authority from the proprietor. Property of FCI. Copyright FCI.

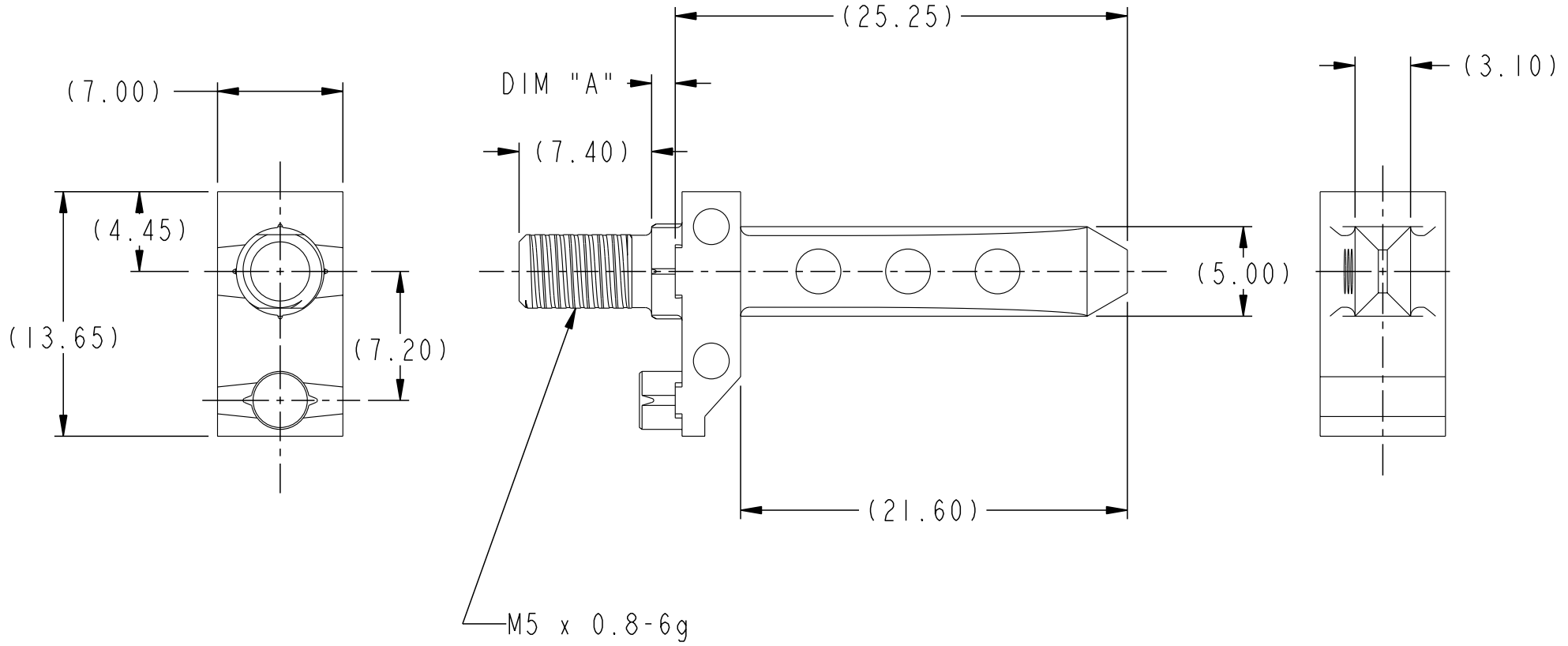

A

B

C

D

rev	ecn no	dr	date
A	V05-0557	-	06/07/05
-	-	-	-
-	-	-	-
-	-	-	-
-	-	-	-
-	-	-	-

<b>A</b> <b>FCI</b>		www.fciconnect.com		surface - <input checked="" type="checkbox"/>	tolerance -	projection	MM	
Dr	T.HOUTZ	1/24/05	Product family	AirMax ACCESSORIES	size	A4	Scale	
Eng	H.NGO	1/24/05	Spec ref	-	ECN	-	3:1	
Chr	H.NGO	1/24/05	Material	SEE NOTES				
Appr	H.NGO	1/24/05						
title				7.2mm VERTICAL GUIDE PIN 2/3 PR, 25.25mm LONG		dwg no	10045368	Rev.
catalog no				10045368-001		CUSTOMER	sheet 1 of 2	A

PDM: Rev:A

STATUS: Released

Printed: Dec 01, 2010

Tous droits strictement reserves. Reproduction ou communication a des tiers interdite sous quelque forme que ce soit sans autorisation écrite du propriétaire. Propriete de c FCI. Droits de reproduction FCI.



All rights strictly reserved. Reproduction or issue to third parties in any form whatever is not permitted without written authority from the proprietor. Property of FCI. Copyright FCI.

PART NUMBER	DIM "A"
10045368-101LF	1.32
10045368-102LF	2.60
10045368-103LF	4.20
10045368-104LF	5.70
10045368-105LF	7.30

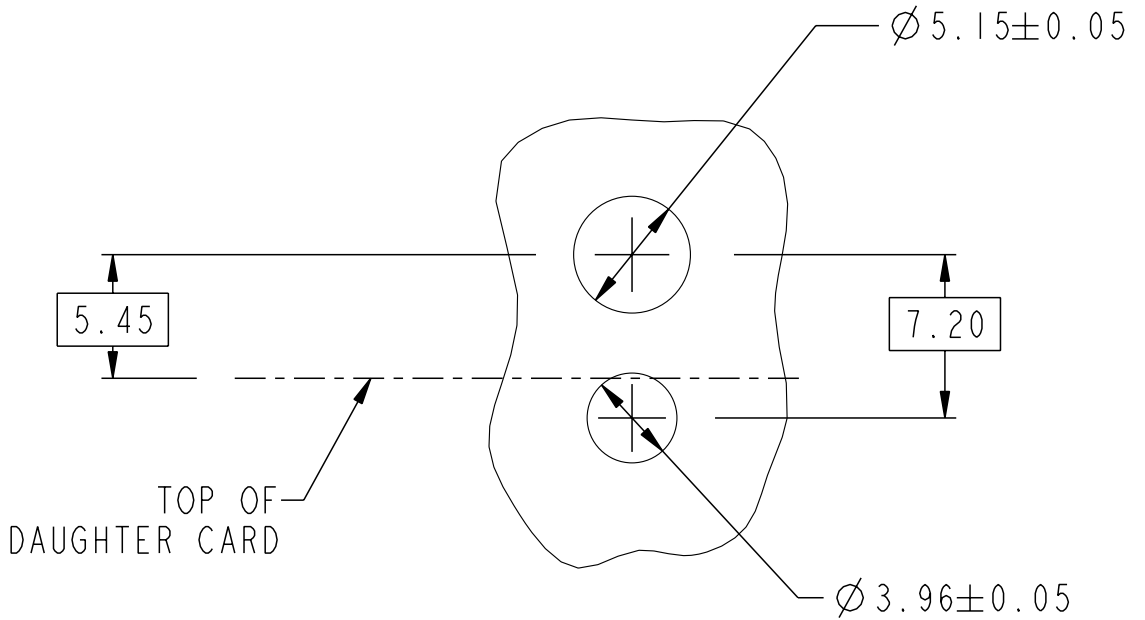

NOTES:

1. MATERIAL: ZINC ALLOY.
2. FINISH: CHROMATE.
- ③ REFER TO CUSTOMER DRAWING 10035911 FOR INFORMATION REGARDING PCB LAYOUT OF POWER AND GUIDE MODULES RELATIVE TO SIGNAL MODULES.
- 4 THIS PRODUCT MEETS EUROPEAN UNION DIRECTIVES AND OTHER COUNTRY REGULATIONS AS DESCRIBED IN GS-22-008.
- 5 PACKAGING MEETS GS-14-920 LEAD FREE LABELING SPECIFICATION.

SEE NOTE 3  
SCALE 3:1

title	7.2mm VERTICAL GUIDE PIN 2/3 PR, 25.25mm LONG	dwg no	10045368	Rev.	A
catalog no	10045368-001	CUSTOMER	sheet 2 of 2		