

THIS DRAWING IS UNPUBLISHED. RELEASED FOR PUBLICATION  
 © COPYRIGHT - By - ALL RIGHTS RESERVED.

REVISIONS				
P	LTR	DESCRIPTION	DATE	APVD
C		PER ECR-16-005636	10MAY2016	GSK AP

- Notes:
1. Assembly per assembly instruction 114-32111.
  2. Electrical test:  
100% open short & miss wire test  
contact resistance: 2 Ohm max
  - 3 Stripped and tinned. Maximum conductor diameter after tinning 2.10mm.
  - 4 Nut does not need to be completely screwed.

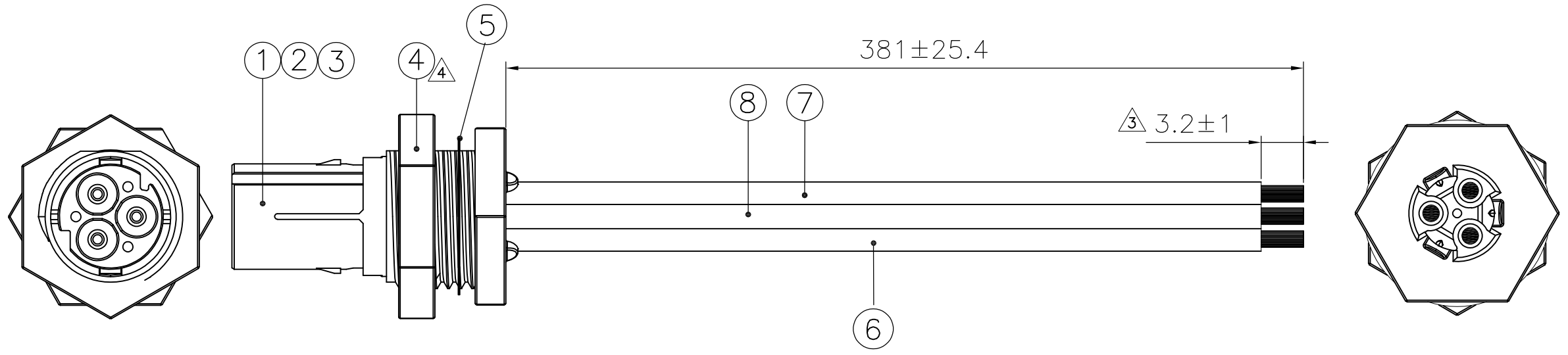

WIRING SCHEME	
CONNECTOR HOUSING (ITEM 1)	WIRE
PE/ $\perp$	GREEN/YELLOW
N	BLUE
L	BROWN

**2829470-1**  
**TE P/N**

QTY	UoM	DESCRIPTION	ITEM
0.41	M	WIRE, HOOKUP, H05V-K, 1.5mm, (YELLOW/GREEN)	8
0.41	M	WIRE, HOOKUP, H05V-K, 1.5mm, (BLUE)	7
0.41	M	WIRE, HOOKUP, H05V-K, 1.5mm, (BROWN)	6
1	PC	PANEL SEAL NECTOR M-LINE	5
1	PC	3P SCREW NUT, PNL MNT	4
1	PC	LOCKING FOR CONTACTS M-LINE	3
3	PC	PIN, CRIMP, 16-18 AWG	2
1	PC	3P PIN HSG, PNL MNT, CODE A	1

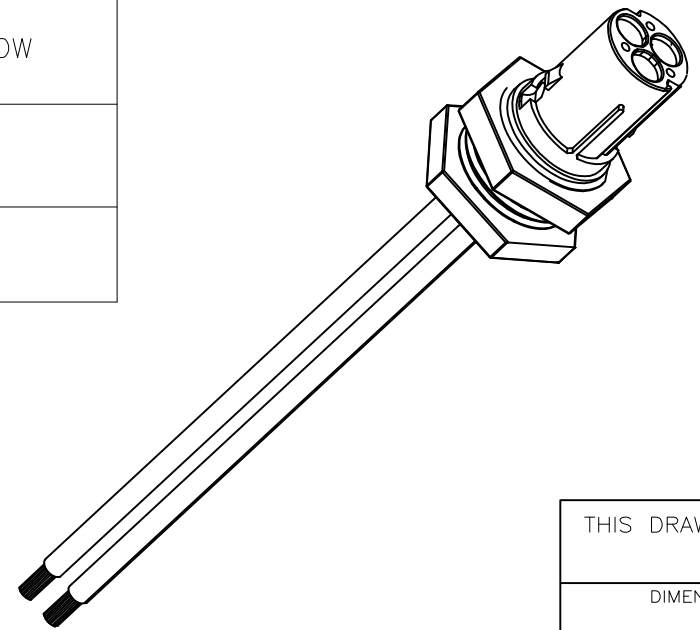

THIS DRAWING IS A CONTROLLED DOCUMENT.		DWN T.BURZYŃSKI 25MAY2015	<b>STE</b> TE Connectivity	
DIMENSIONS: mm		CHK A.V.ZANDVOORT 25MAY2015		
TOLERANCES UNLESS OTHERWISE SPECIFIED:		APVD A.V.ZANDVOORT 25MAY2015	NAME PIGTAIL BULKHEAD PIN STD HARMONIZED CABLE	
0 PLC ± 0,5		PRODUCT SPEC	-	
1 PLC ± 0,5		APPLICATION SPEC	-	
2 PLC ± 0,5		WEIGHT	SIZE A3	CAGE CODE 00779
3 PLC ± -		MATERIAL -	DRAWING NO C-2829470	RESTRICTED TO -
4 PLC ± -			CUSTOMER DRAWING	
ANGLES ± 2°		SCALE NTS		
FINISH -		SHEET 1 OF 1		
		REV C		